

Machine Vision Lens

LE-MV-3520-TS

**High Resolution Fixed Focal
2/3" 35mm Lens**

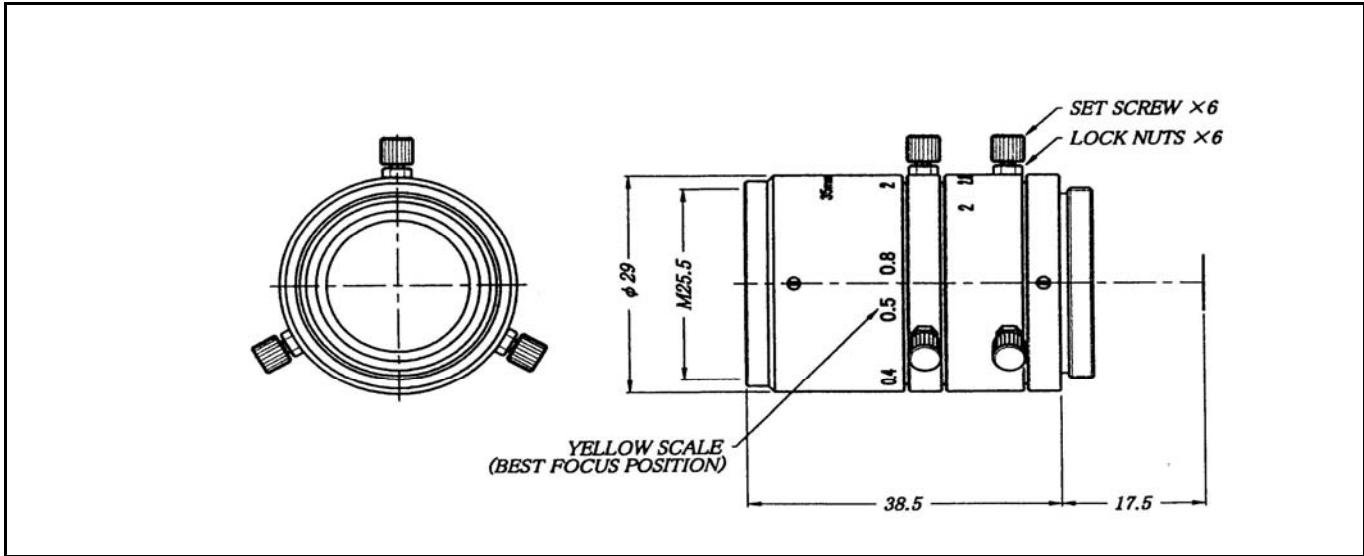

(Unit: mm)

Image Format	2/3-inch
Focal Length	35mm
Max. Aperture	F=1 : 2.0
Iris Operation	Manual with lock
Iris Range	F2.0 - 22
View Angle	Horizontal: 14° 33 Vertical: 10° 45 Diagonal: 17° 86
Lens Mount	C-mount
MOD(Minimum Object Distance)	0.25m
Back Focal Length	18.06mm
Filter Screw Size	25.5mm P=0.5
Dimensions	φ 29.0mm x 38.5mm
Weight	55g
TV Distortion	On 2/3" CCD : -0.02%