

# Machine Vision Lens

LE-MV-2514TS

**High Resolution Fixed Focal  
2/3" 25mm Lens**

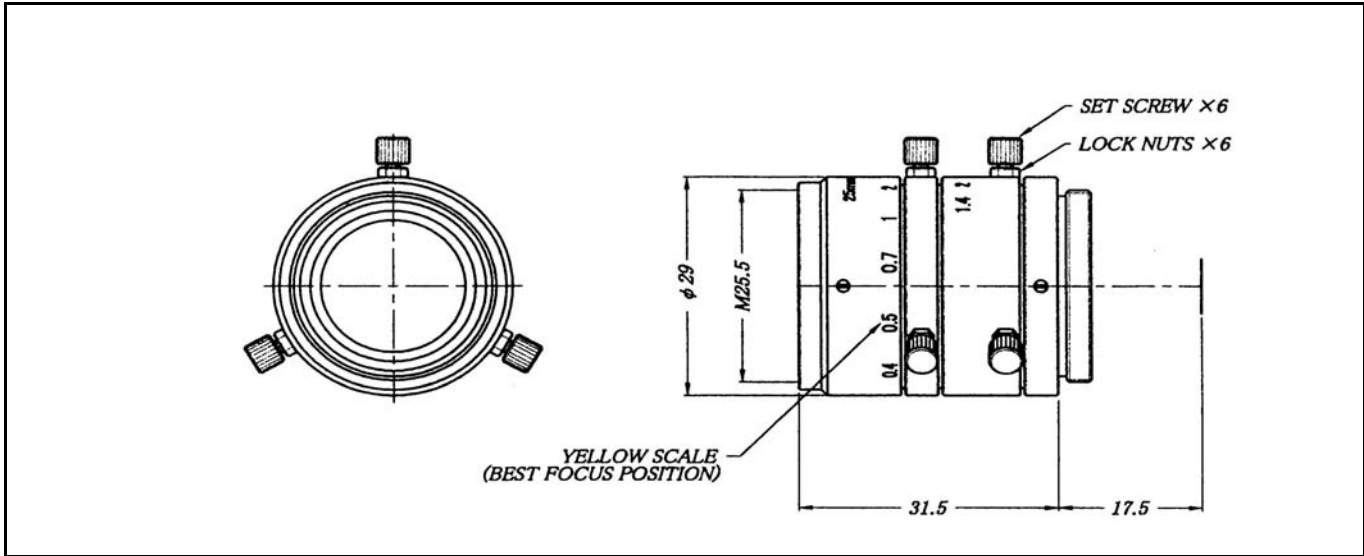

(Unit: mm)

<b>Image Format</b>	2/3-inch
<b>Focal Length</b>	25mm
<b>Max. Aperture</b>	F=1 : 1.4
<b>Iris Operation</b>	Manual with lock
<b>Iris Range</b>	F1.4 - 16
<b>View Angle</b>	<b>Horizontal:</b> 20° 10 <b>Vertical:</b> 15° 10 <b>Diagonal:</b> 24° 95
<b>Lens Mount</b>	C-mount
<b>MOD(Minimum Object Distance)</b>	0.25m
<b>Back Focal Length</b>	13.13mm
<b>Filter Screw Size</b>	25.5mm P=0.5
<b>Dimensions</b>	φ 29.0mm x 31.5mm
<b>Weight</b>	45g
<b>TV Distortion</b>	On 2/3" CCD : -0.30%