

## ALYSIUM PRODUCT DOCUMENT SPECIFICATION PACK

This Document Pack is for the Specification:

**A74-9968[1].000**                      **X**                      **-**

Which comprises of the following SubComponents:

ATR 0000.003	X	Validated	18/10/2016 07:57:00	ATR 0000.003.pdf	1
ATE 2000	00	Validated	26/04/2016 03:04:00		
ETR 0901.002	X	Validated	20/10/2016 02:03:00	ETR 0901.002.pdf	1
ETE 0900	00	Validated	26/04/2016 03:00:00		
LPR 0000(USB 3 AM-MicM).001	X	Validated	11/07/2017 05:40:00	LPR 0000(USB 3 AM-MicM).001.pdf	1
P74-9968[1].000	X	Validated	27/04/2017 04:56:00	P74-9968.000.pdf	1
A86-4730(T)	00	Validated	28/04/2017 05:04:00	A86-4730(T).pdf	1
USB A (DC) Bracket	02	Validated	11/07/2017 05:55:00	USB A 3.0 (DC) Bracket(02).pdf	1
				USB A 3.0 (DC) Bracket(02).pdf	1
A99-7550					
USB A 3.0 (OD5.8 DCT)	00	-		USB A 3.0 (OD5.8 MH).pdf	1
A99-7117					
USB MicB 3.0 s1 (OD5.8 DC)	00	-		USB MicB 3.0 s1 (OD5.8 mh).pdf	1
A99-7045					

Test Equipment	Test Procedure	Acceptable Pass Criteria
<p>PassMark USB 3.0 Loop Back Plug                      Tester                      Model: PMUSB03</p> 	<p>No errors displayed or counted in the interface.</p> <p>Speed should always be 5Gb/s and the voltage should be around 5V with a tolerance of <math>\pm 50</math> mV.</p> <p>Test duration must be set to 0.5 min.</p>	<p>The superspeed values for READ and WRITE speed should be above 2000Mb/s or 200MB/s.</p> <p>When the assemblies are connected with the loopback device with the CPU, the interface of software will detect super speed and can run up to 30s cycle time. Only then the assemblies are categorized as PASS.</p> <p>But, if the interface of the software only detects high speed, then the assemblies are automatically categorized as FAIL.</p>

**Note:**

The above test is applicable only for USB 3 cable assembly USB A 3.0 TO USB Micro B 3.0 only.

**Sampling Size:**

100% Check

## Electrical Test Criteria

- 1) Open/Short circuit
- 2) Intermittent
- 3) Insulation Resistance

## Hi Pot Tester Model

CT-8681N (ATPN : ETE 0900)

## Measurement Parameters

Voltage = 300VDC,

Insulation Resistance > 20M Ohm,

Time = 0.1s

## Sampling size

100% Check

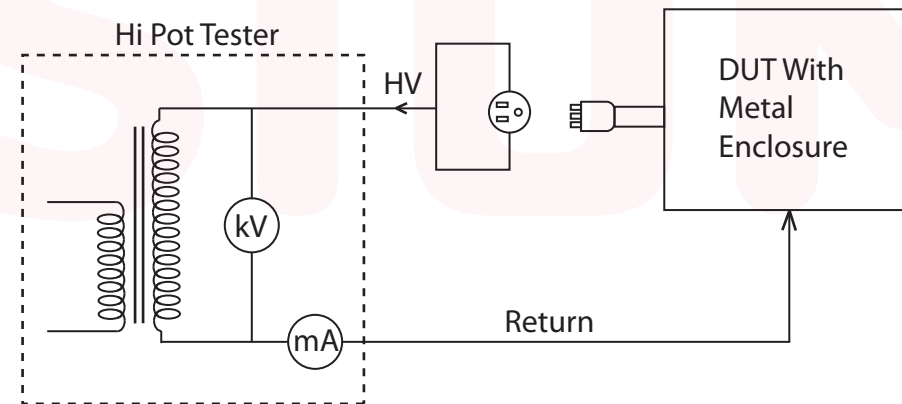

Simulated Line Leakage Diagram



# Heat Sealed PE Bag Packaging

## Cable Assembly Example:

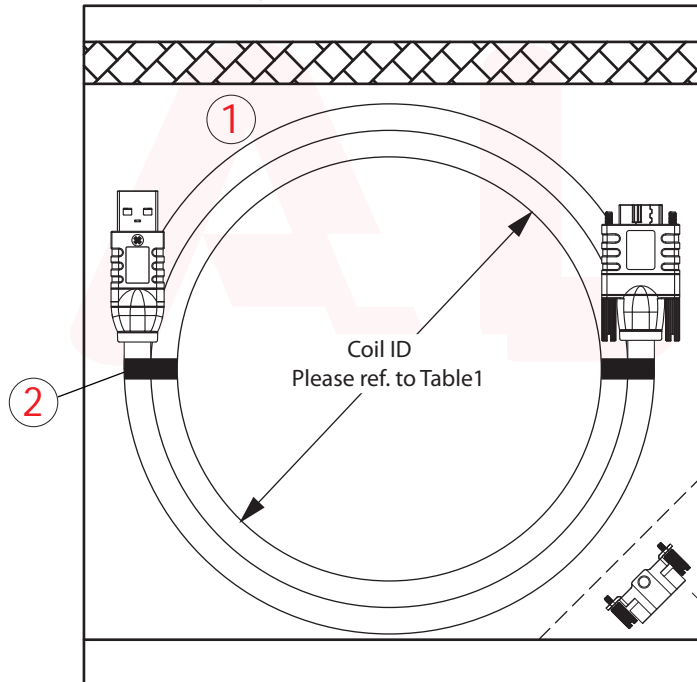

### Packaging Content:

- 1) Basic Assembly x1
- 2) Magic Tie/ Cable Tie x2
- 3) Accessories  
 -USB A 2.0/ 3.0 Locking Bracket x1 + Thumbscrew x2 + Flat head Screw x1
- 4) White Pad Print on Cable

Table 1: Assembly Coiling Inner Diameter Unless Otherwise Specified

Type of Cable [Jacket OD(mm)]	Coil ID (mm)
Default	150
MCD-USB-211[7.3]	250
MCD-USB-213[7.4]	250
MCD-USB-213(T)[8.0]	250
MCD-USB-209B[7.4]	250
A87-3502[9.45]	250

### Cable Label Guideline

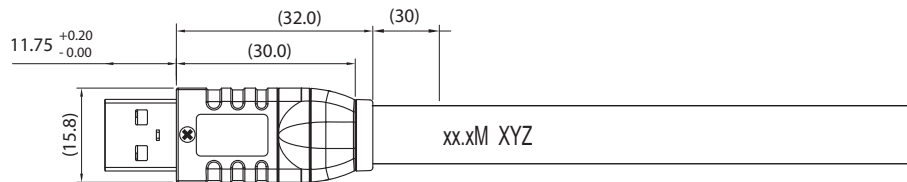

### PAD PRINT <WHITE>

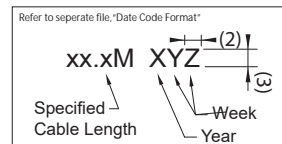



L(Length in meter)As per Customer Requirements (max. 5M recommended)

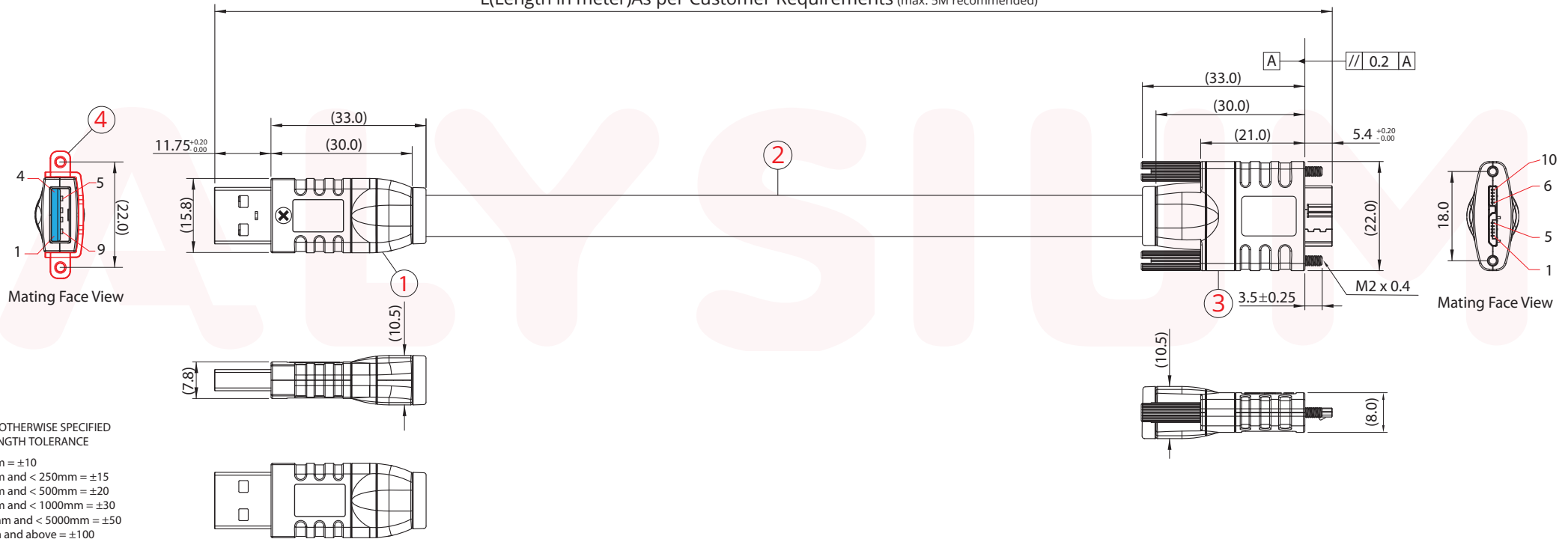

UNLESS OTHERWISE SPECIFIED  
 ASSY LENGTH TOLERANCE

- < 150mm = ±10
- ≥ 150mm and < 250mm = ±15
- ≥ 250mm and < 500mm = ±20
- ≥ 500mm and < 1000mm = ±30
- ≥ 1000mm and < 5000mm = ±50
- 5000mm and above = ±100

## RoHS COMPLIANT

This document is the property of Alysium-Tech. It must not be copied or otherwise disclosed without prior written consent



### BILL OF MATERIALS

Item	Description
1	A+ USB A 3.0 (OD5.8 Die Cast Threaded) Die Cast Shell incl. M2.6x2.5 screw (to be disposed, when bracket is applied)
2	A86-4730(T), [OD=6.2mm] <BLK> E357566-ALY-T UL2725 2STP(#26x2C)+STP#28+2C#22
3	A+ USB MicB 3.0 sl (OD5.8 Die Cast) Die Cast Shell
4	USB A 3.0 (Die Cast) sl Bracket (Refer to Accessories Details)

### WIRING DIAGRAM

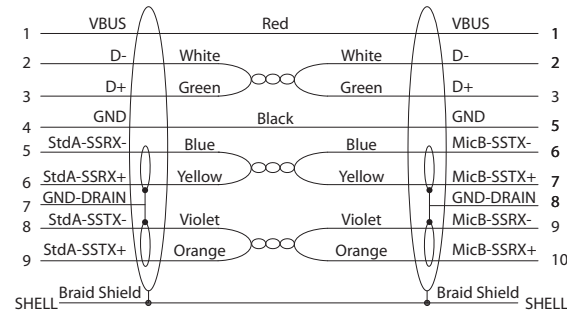

### ACCESSORIES DETAILS

This Assembly/ Item ④ inclusive of accessories as per below shown:

- A) Metal Sheet Bracket for USB A 3.0 (1pc)
- B) M2 Thumb Screw (2pcs)
- C) M2.5x3.0 Flat Head Screw (Pre-Installed in Metal Sheet Bracket) ① (1pc)

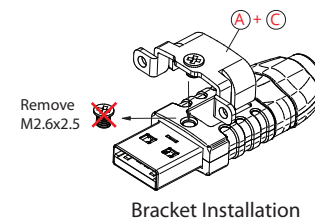

Bracket Installation

