

Rev No.	Description	Date	Name
A	First light	31/01/07	A.Vismara

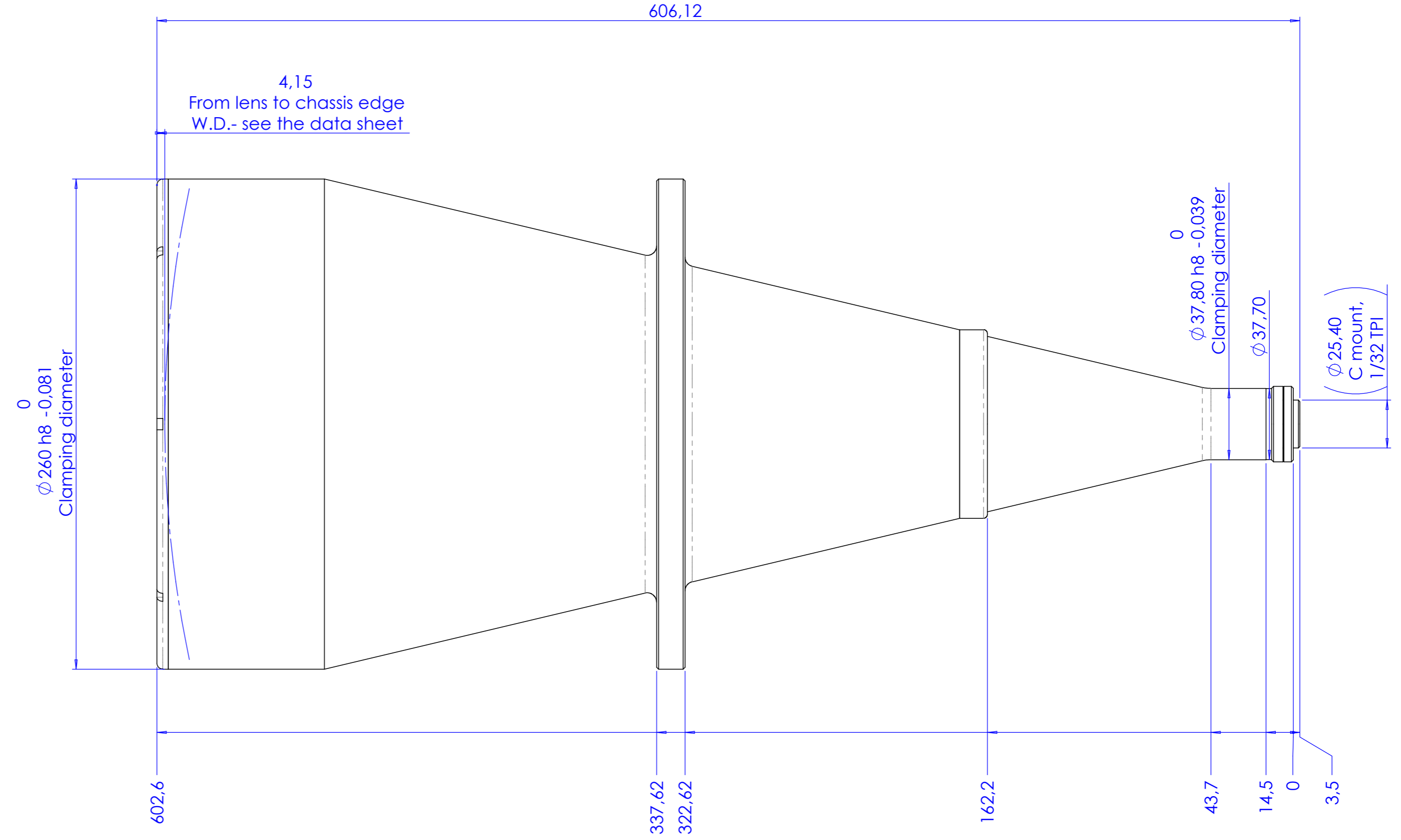
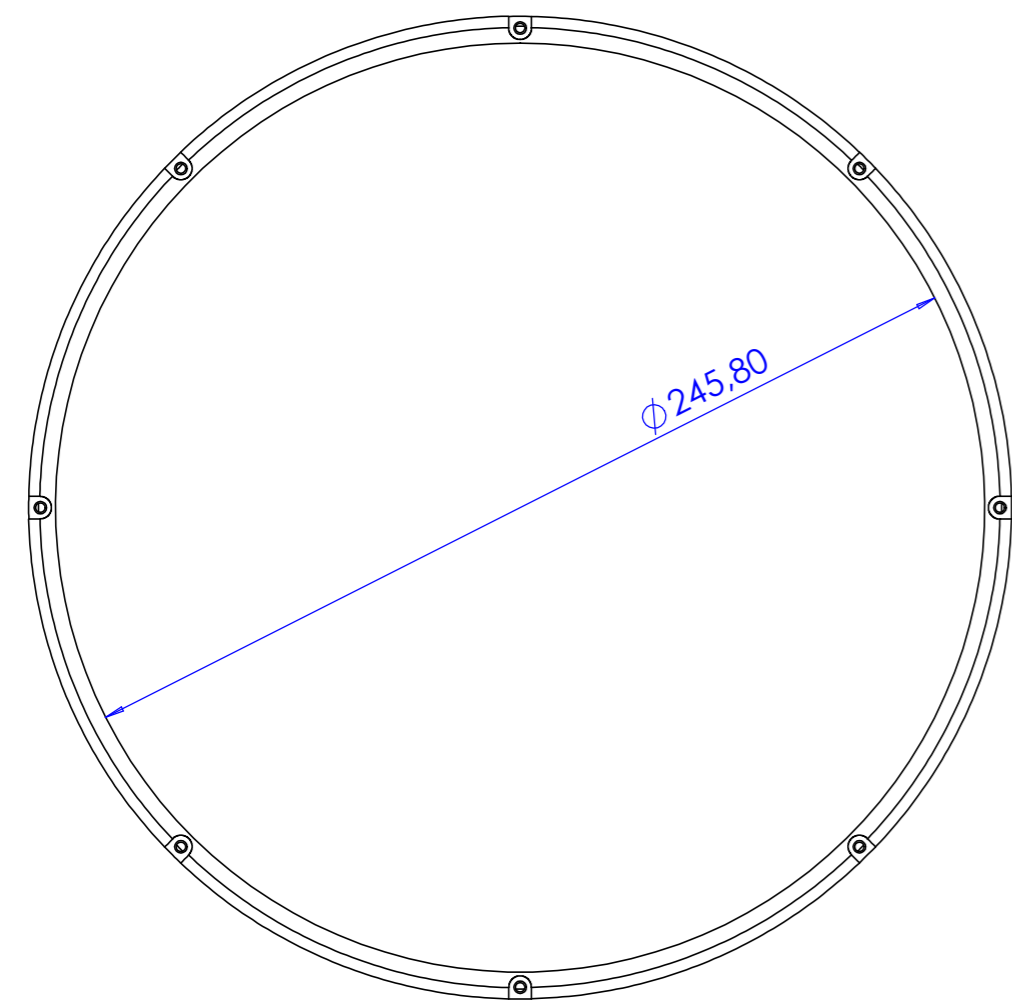
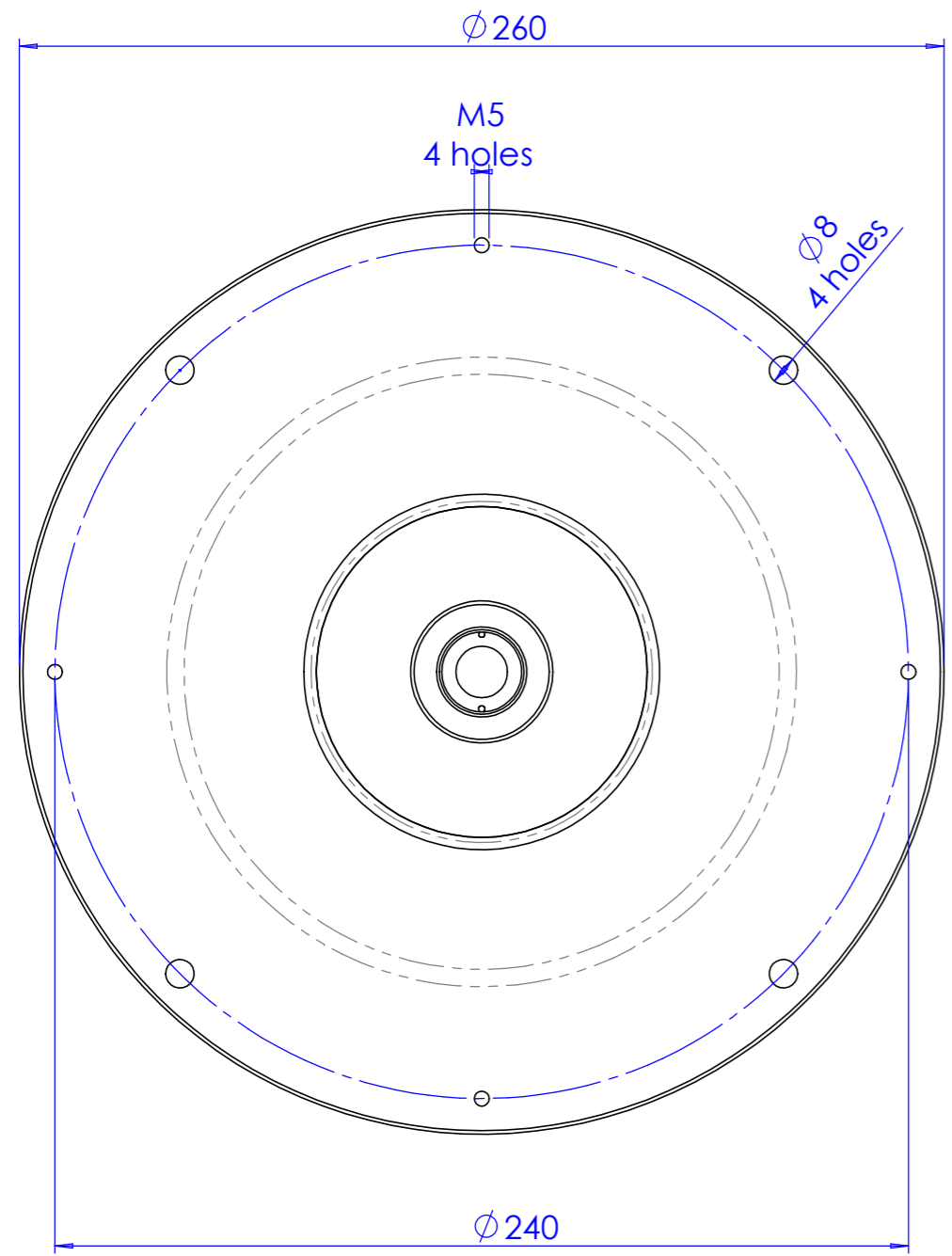

Material	N.A.	Mass	11.3 kg	Scale	1:2
Surface treatment	N.A.	Project-Prod.Item/Instrument Telecentric lens 12 192			
Geometrical tolerance (ISO 2768-2)		Class	K	Undimensioned bevels	1x45°
0.5	>3+	>6+	>30+	>120	>400+
+3	6	30	120	+400	+1000
±0,1	±0,1	±0,2	±0,3	±0,5	±0,8
		Class	m	Undimensioned radii	R 0.5
www.opto-engineering.com		Date	Name		
		Designed	31/01/07	A.Vismara	
		Draw	31/01/07	A.Vismara	
		Checked	X	C.Sedazzari	
OPTO ENGINEERING S.r.l. - 46100 Mantova Italy - Via Cremona, 29 - Tel. +39 0376 229585 - e-mail: info@opto-engineering.com - http://www.opto-engineering.com		Drawing No.		02571-0-A	Sheet 1/1