

Rev No.	Description	Date	Name
A	First light	31/01/07	A.Vismara

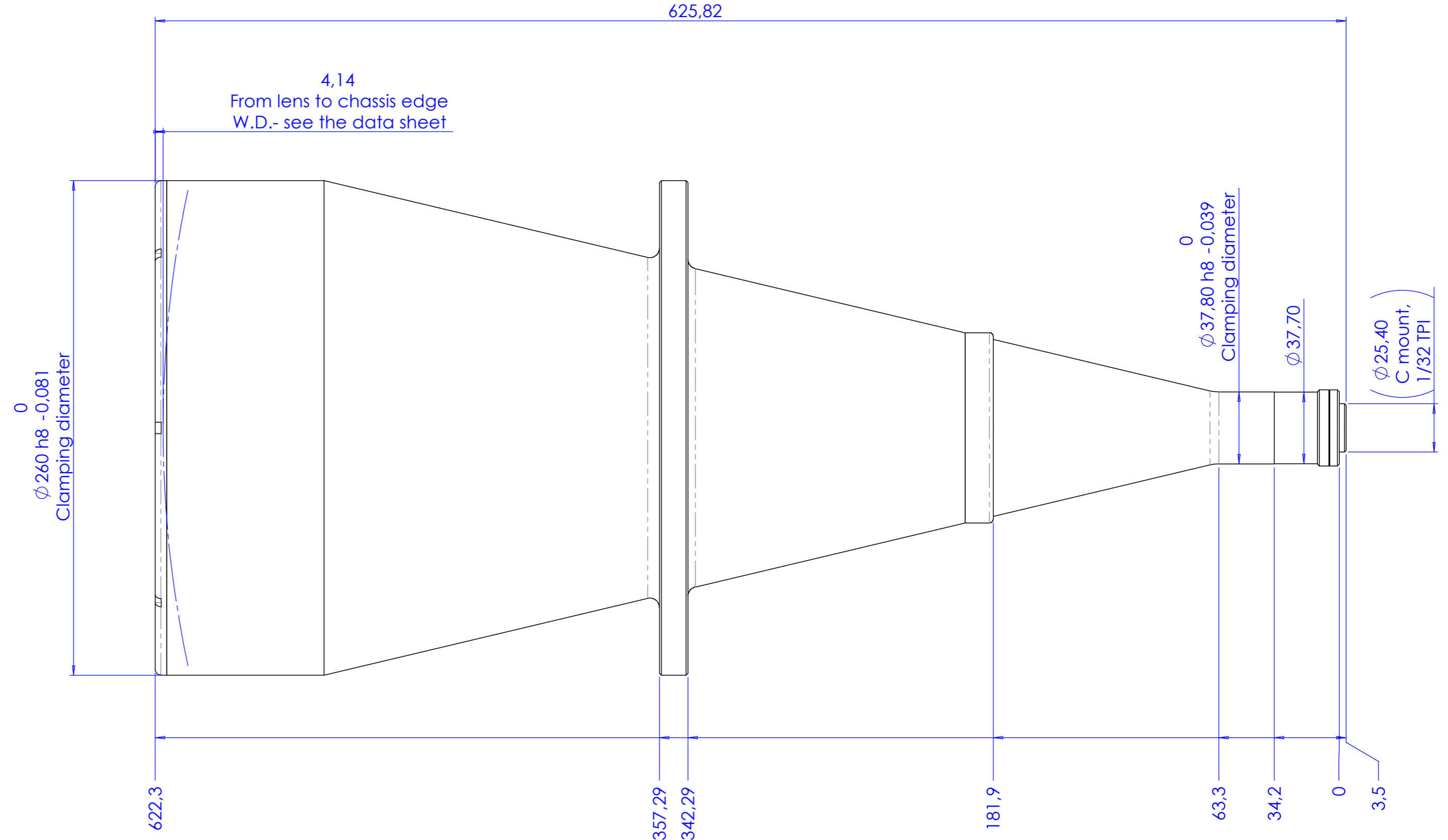
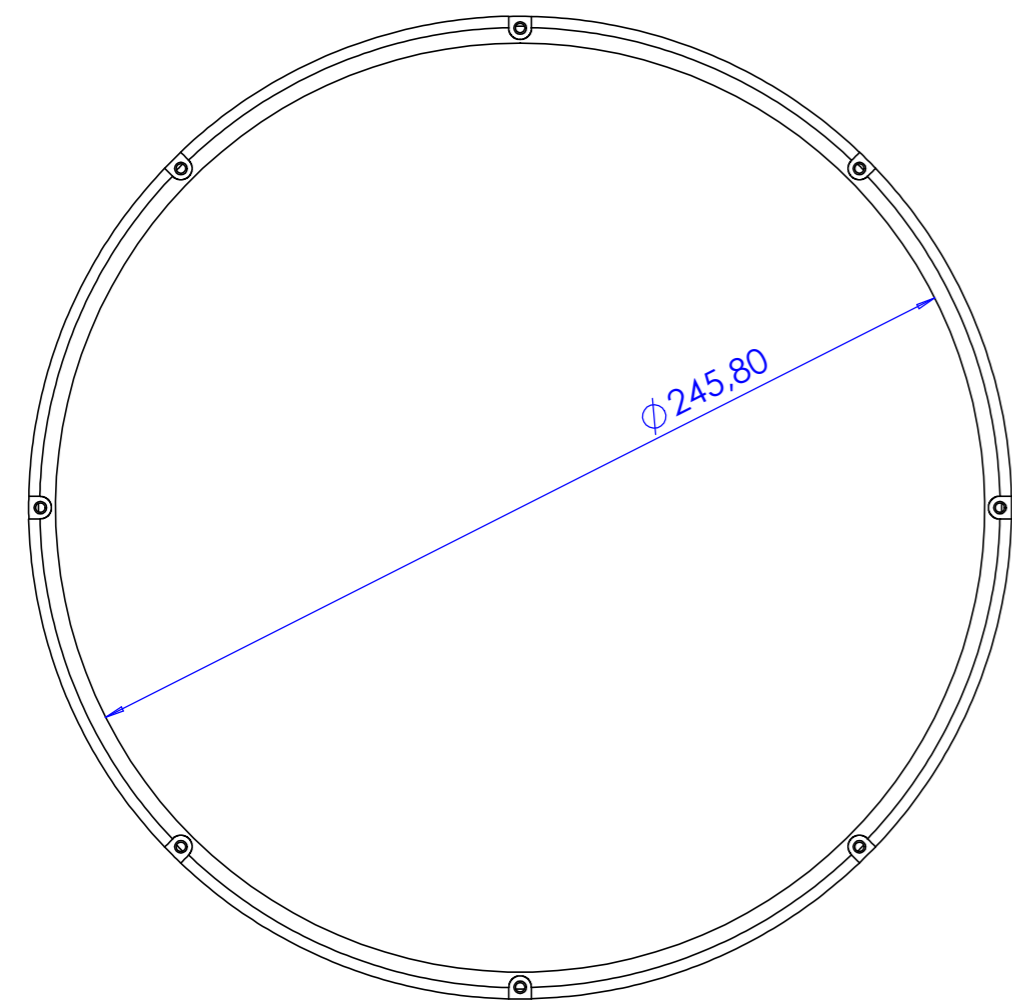
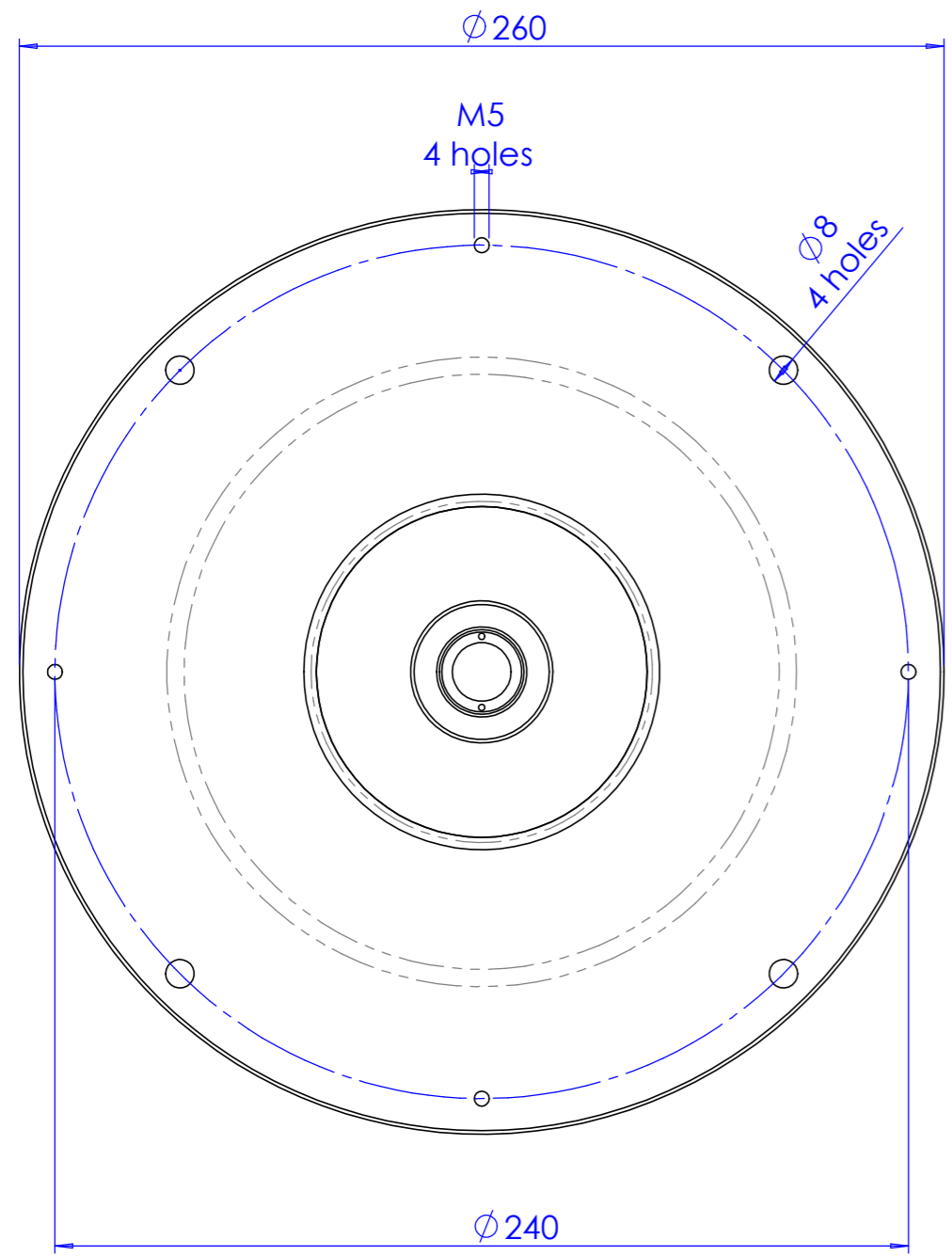

Material	N.A.	Mass	11.4 kg	Scale	1:2
Surface treatment	N.A.	Project-Prod.Item/Instrument Telecentric lens 23 192			
Geometrical tolerance (ISO 2768-2)		Class	K	Undimensioned bevels	1x45°
0.5	>3±	>6±	>30±	>120	>400±
+3	6	30	120	+400	+1000
±0,1	±0,1	±0,2	±0,3	±0,5	±0,8
Linear tolerance (ISO 2768-2)		Class	K	Undimensioned radii	R 0.5
0.5	>3±	>6±	>30±	>120	>400±
+3	6	30	120	+400	+1000
±0,1	±0,1	±0,2	±0,3	±0,5	±0,8
Date		Name		Drawing No.	
31/01/07		A.Vismara		02551-0-A	
31/01/07		A.Vismara		1/1	
Checked		X		C.Sedazzari	
Reproduction forbidden without specific authorization					
OPTO ENGINEERING S.r.l. - 46100 Mantova Italy - Via Cremona, 28 - Tel/fax +39 0376 263525 - e-mail info@opto-engineering.com - http://www.opto-engineering.com					