

Rev No.	Description	Date	Name
A	First light	26/05/06	A.Vismara
A	New design with flange attachment	15/09/09	A.Vismara

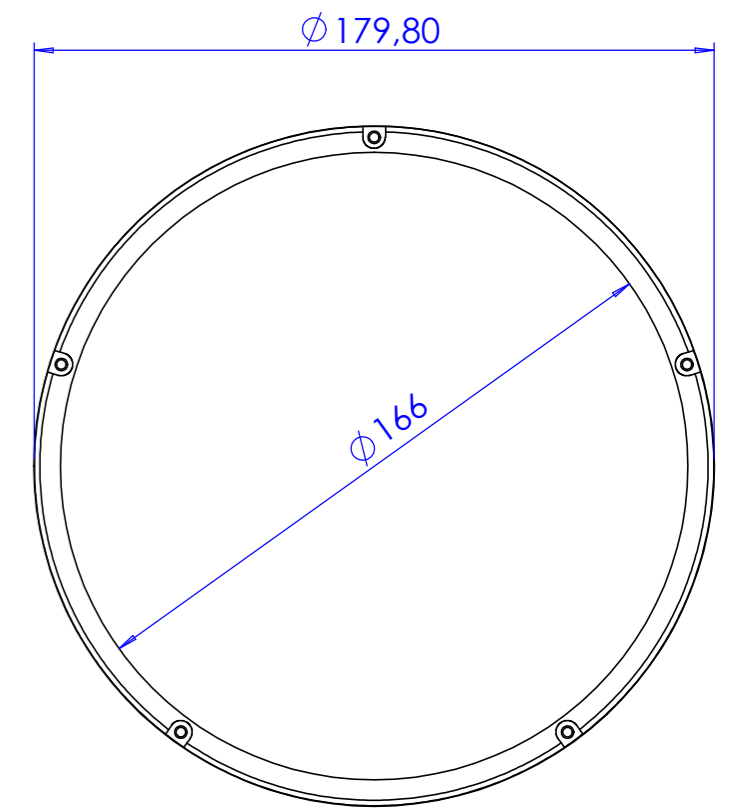
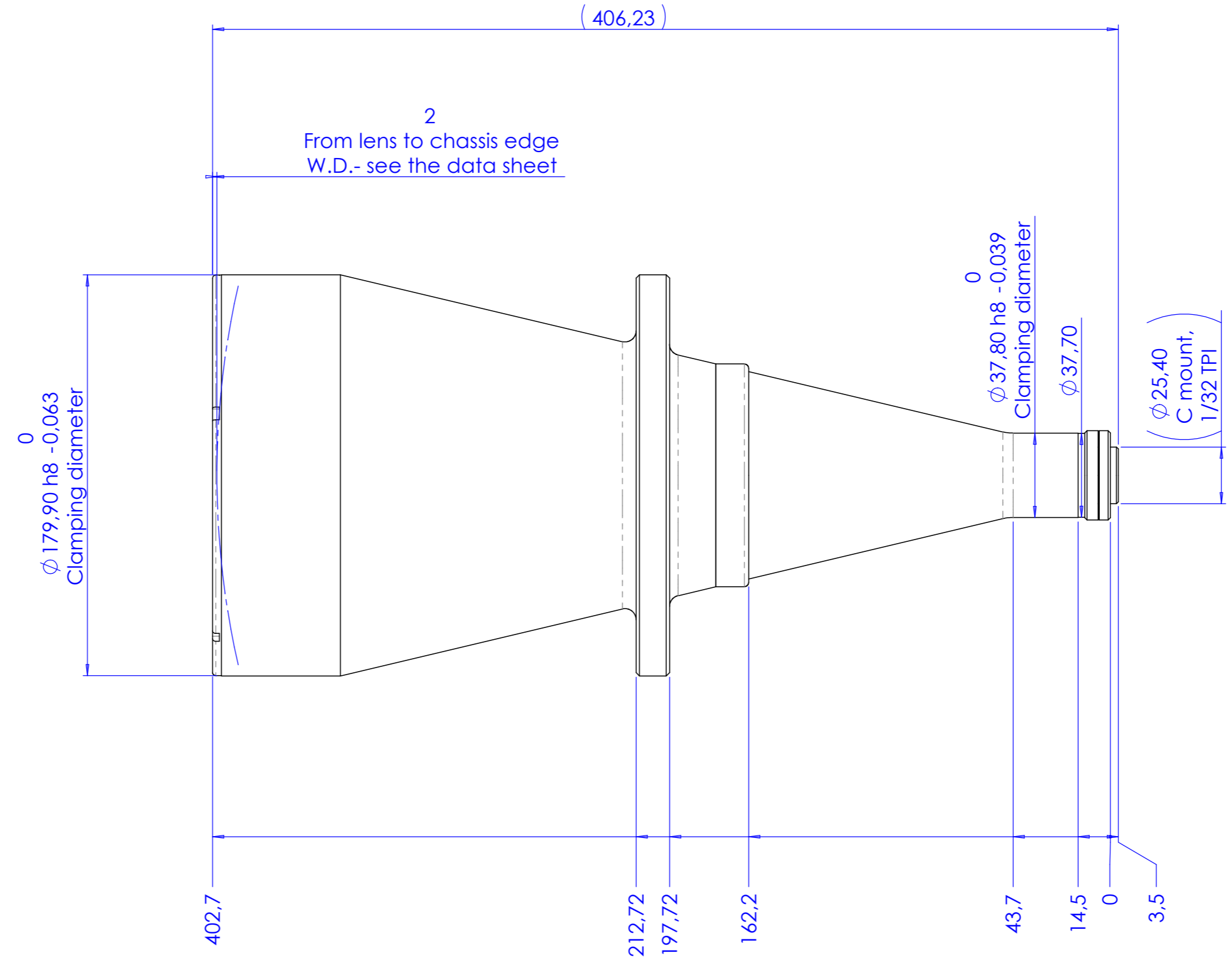
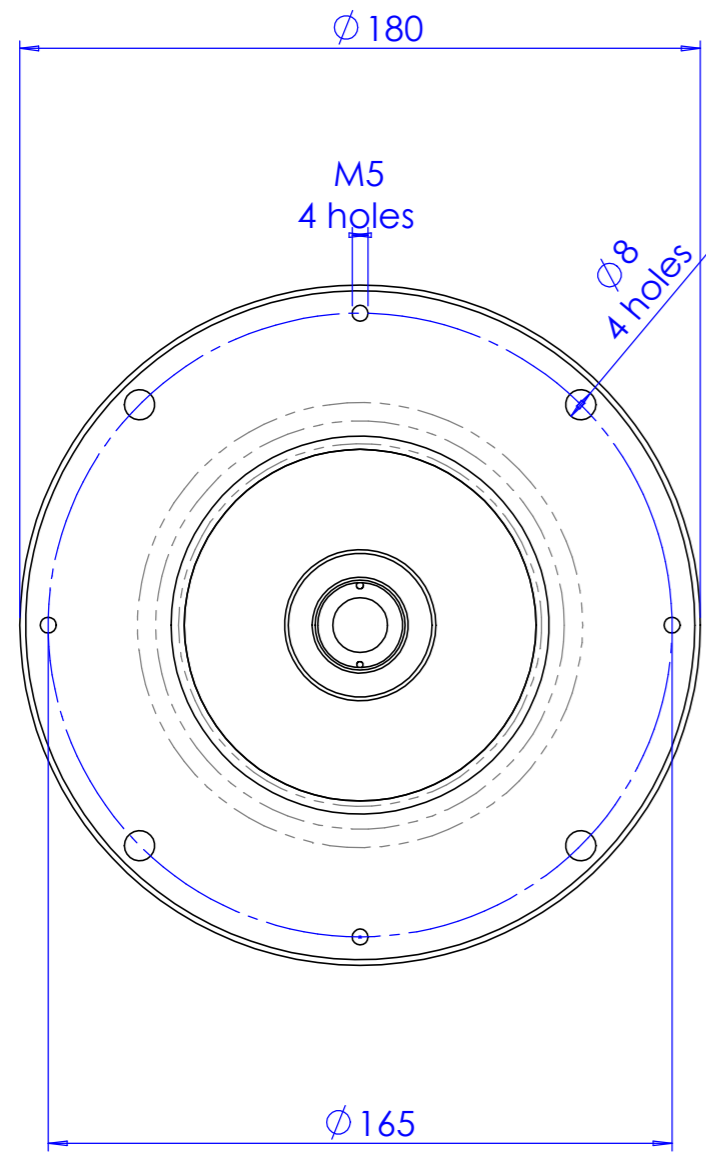

Material	N.A.	Mass	5.3 kg	Scale	1:2
Surface treatment	N.A.	Project-Prod.Item/Instrument Telecentric lens 12 120			
Geometrical tolerance (ISO 2768-2)		Class	K	Undimensioned bevels	1x45°
Linear tolerance (ISO 2768-2)		Class	m	Undimensioned radii	R 0.5
0.5	>3+	>6+	>30+	>120	>400+
+3	6	30	120	+400	+1000
±0.1	±0.1	±0.2	±0.3	±0.5	±0.8
				±1.2	±2
www.opto-engineering.com		Date	Name	Drawing No.	
		Designed	26/05/06	A.Vismara	02521-0-B
		Draw	15/09/09	A.Vismara	1/1
		Checked	X	C.Sedazzari	Reproduction forbidden without specific authorization
OPTO ENGINEERING S.r.l. - 46100 Mantova Italy - Via Cremona, 28 - Tel/fax +39 0376 263525 - e-mail info@opto-engineering.com - http://www.opto-engineering.com					