

Rev No.	Description	Date	Name
A	First light	14/04/06	A.Vismara

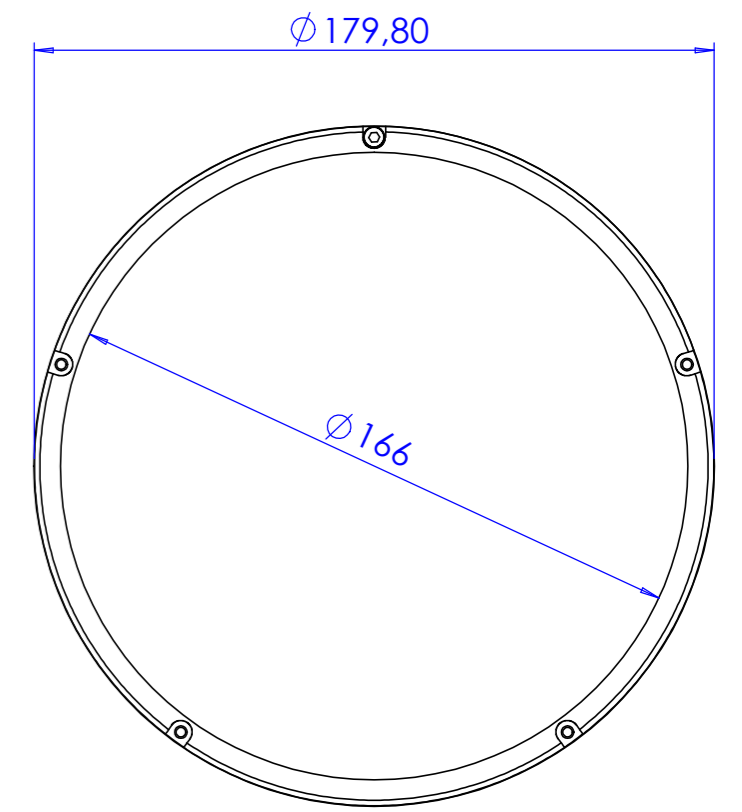
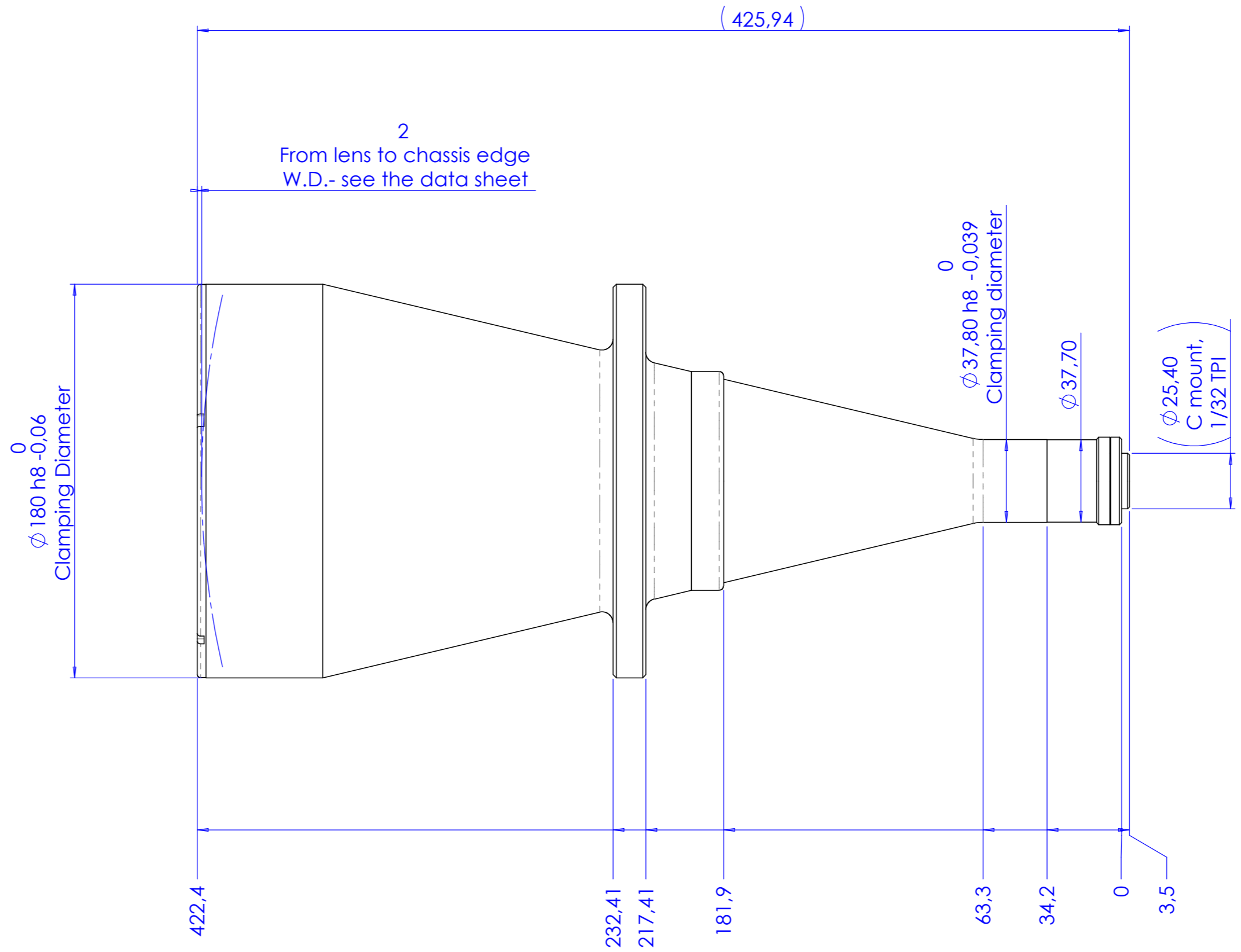
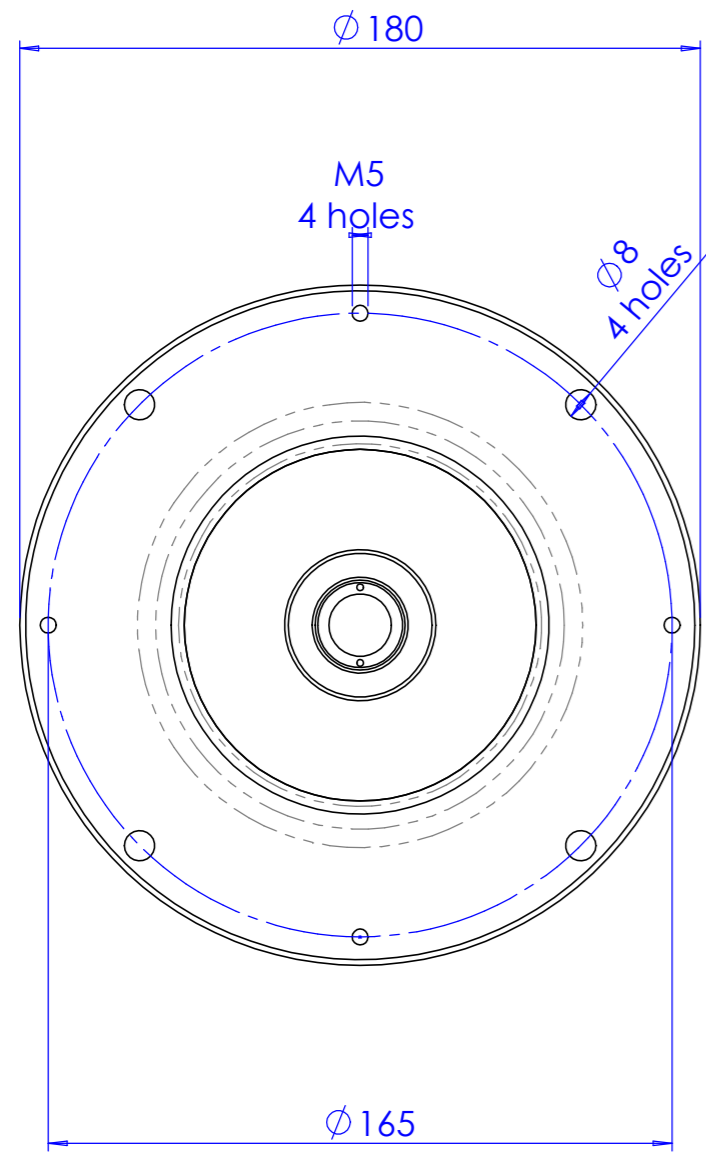

Material	N.A.	Mass	5.3 kg	Scale	1:2
Surface treatment	N.A.	Project-Prod.Item/Instrument Telecentric lens 23 120			
Geometrical tolerance (ISO 2768-2)		Class	K	Undimensioned bevels	1x45°
Linear tolerance (ISO 2768-2)		Class	m	Undimensioned radii	R 0.5
0.5	>3+	>6+	>30+	>120	>400+
+3	6	30	120	+400	+1000
±0,1	±0,1	±0,2	±0,3	±0,5	±0,8
				±1,2	±2
www.opto-engineering.com		Date	Name		
Designed		14/04/06	A.Vismara		
Draw		14/04/06	A.Vismara		
Checked		X	C.Sedazzari		
OPTO ENGINEERING S.r.l. - 46100 Mantova Italy - Via Cremona, 28 - Tel/fax +39 0376 263525 - e-mail info@opto-engineering.com - http://www.opto-engineering.com		Drawing No.		Sheet	
		02501-0-A		1/1	
Reproduction forbidden without specific authorization					