

Rev No.	Description	Date	Name
A	First light	14/06/06	A.Vismara

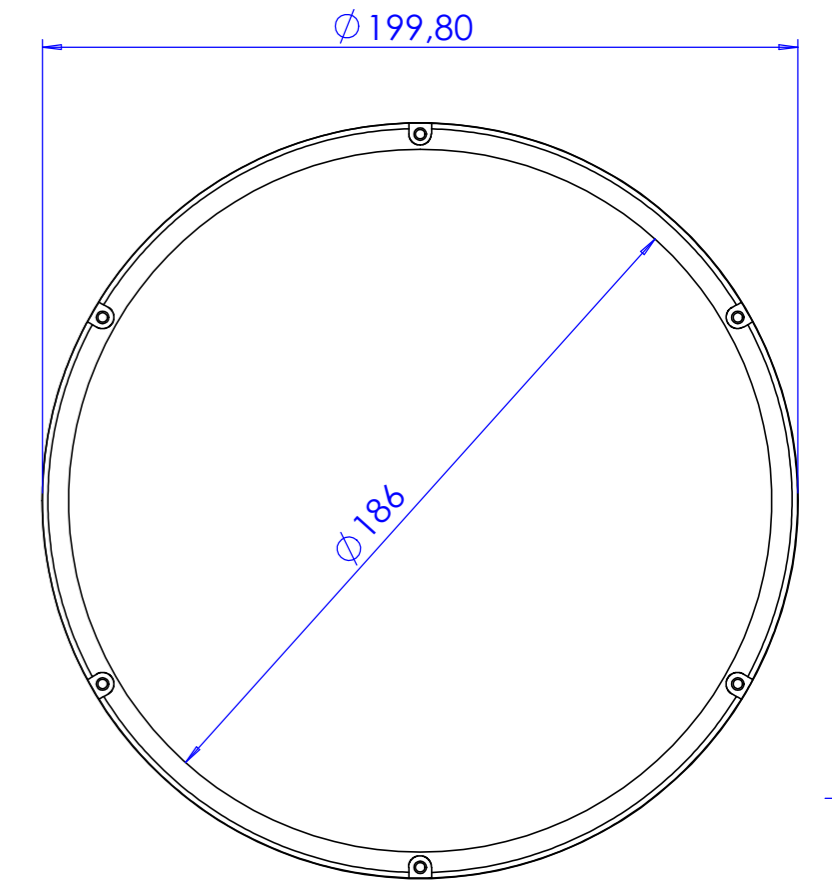
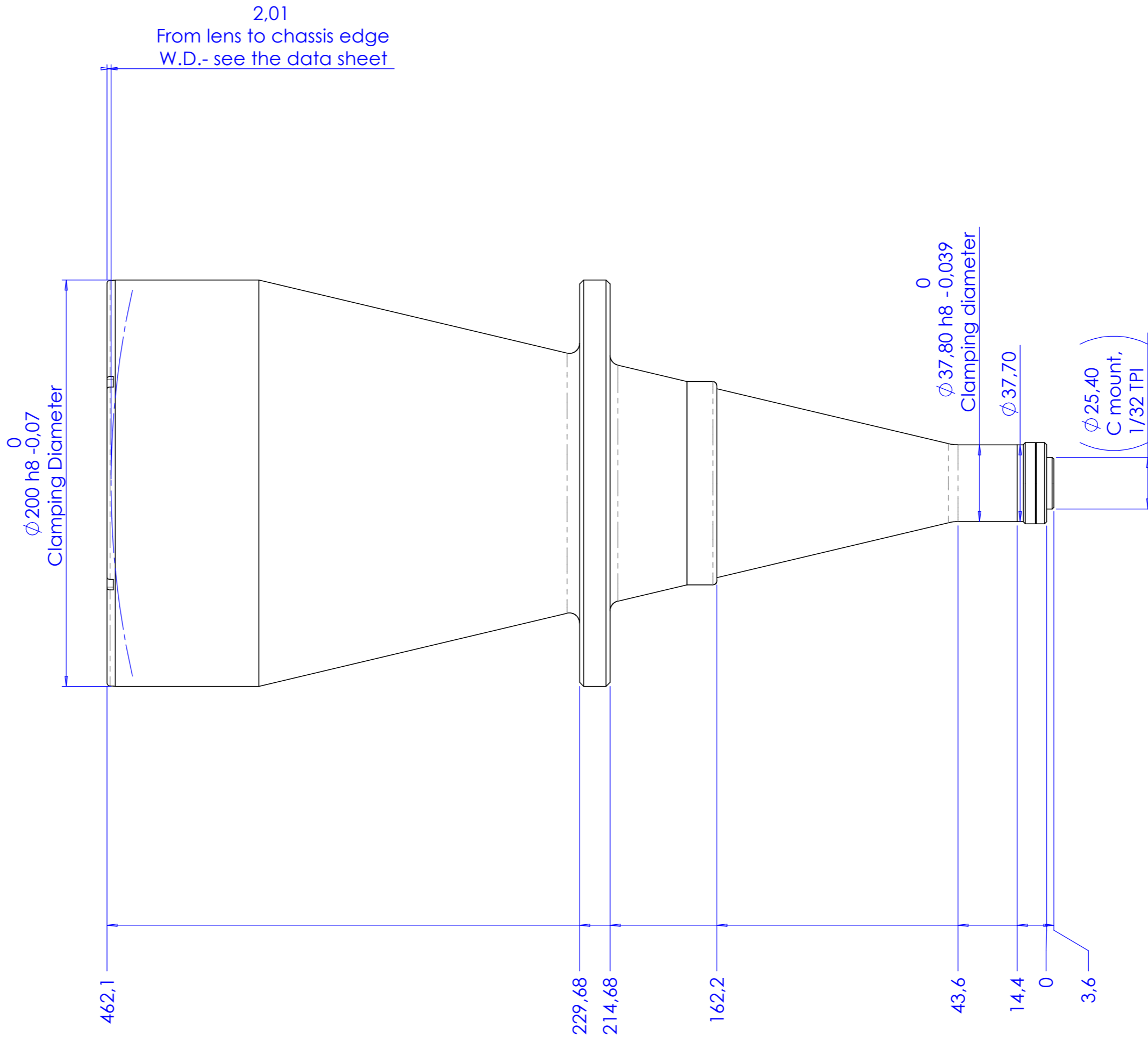
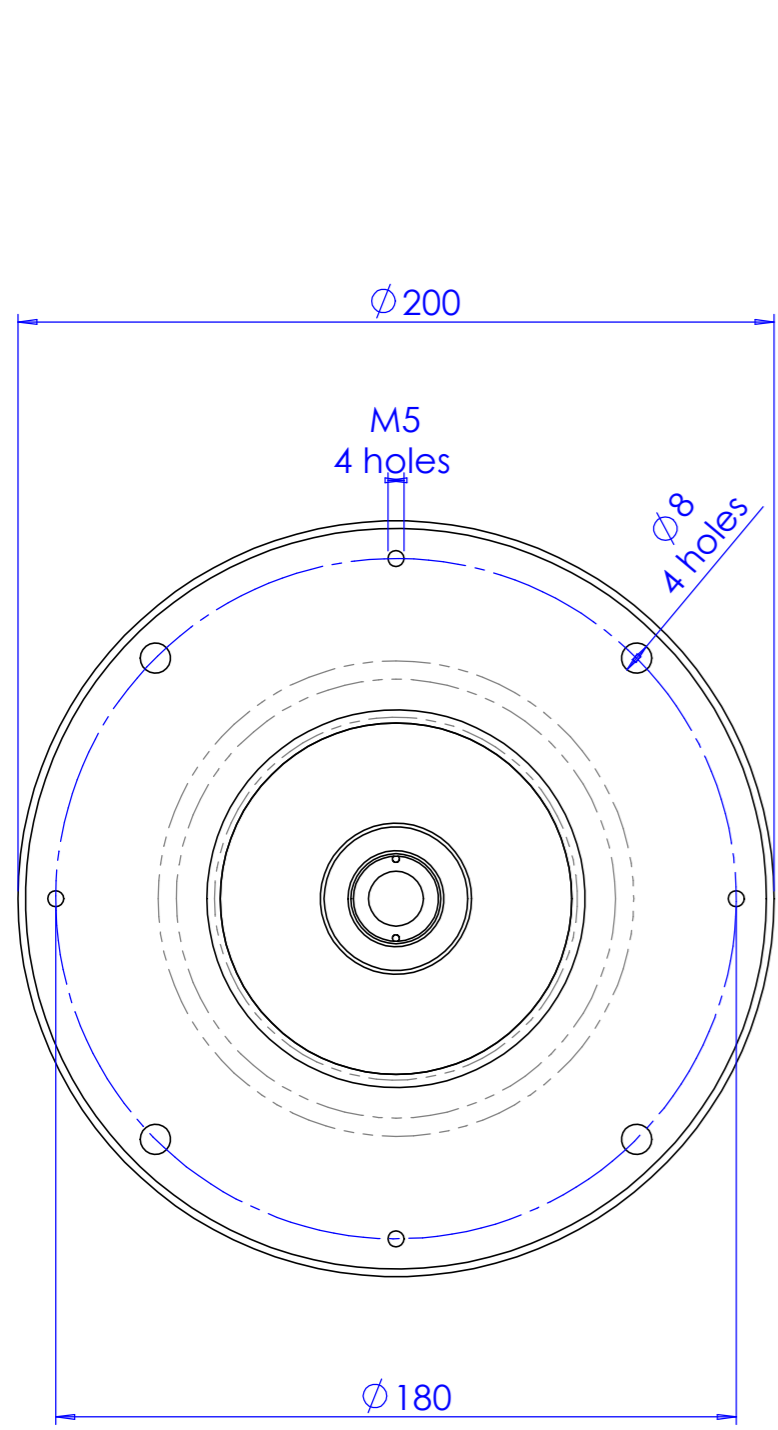

Material	N.A.	Mass	6.5 kg	Scale	1:2
Surface treatment	N.A.	Project-Prod.Item/Instrument Telecentric lens 12 144			
Geometrical tolerance (ISO 2768-2)		Class	K	Undimensioned bevels	1x45°
Linear tolerance (ISO 2768-2)		Class	m	Undimensioned radii	R 0.5
0.5	>3+	>6+	>30+	>120	>400+
+3	6	30	120	+400	+1000
±0,1	±0,1	±0,2	±0,3	±0,5	±0,8
					±1,2
					±2
Date		Name		Drawing No.	
Designed 14/06/06		A.Vismara		02371-0-A	
Draw 14/06/06		A.Vismara		Sheet 1/1	
Checked X		C.Sedazzari		Reproduction forbidden without specific authorization	
OPTO ENGINEERING S.r.l. - 46100 Mantova Italy - Via Cremona, 28 - Tel/fax +39 0376 263525 - e-mail: info@opto-engineering.com - http://www.opto-engineering.com					