

Rev No.	Description	Date	Name
A	First light	12/09/06	A.Vismara
B	Length of C thread	12/01/09	A.Vismara

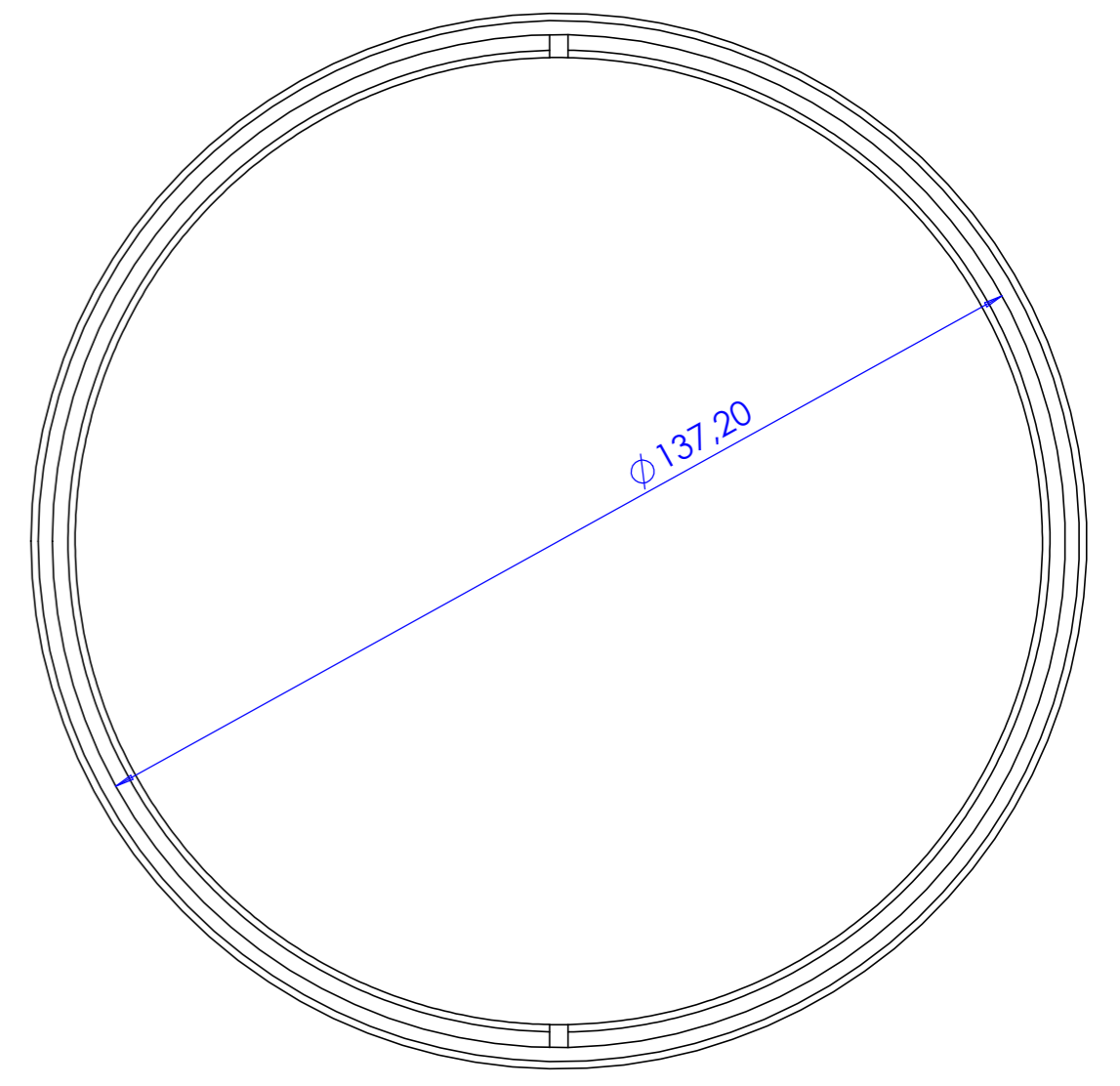
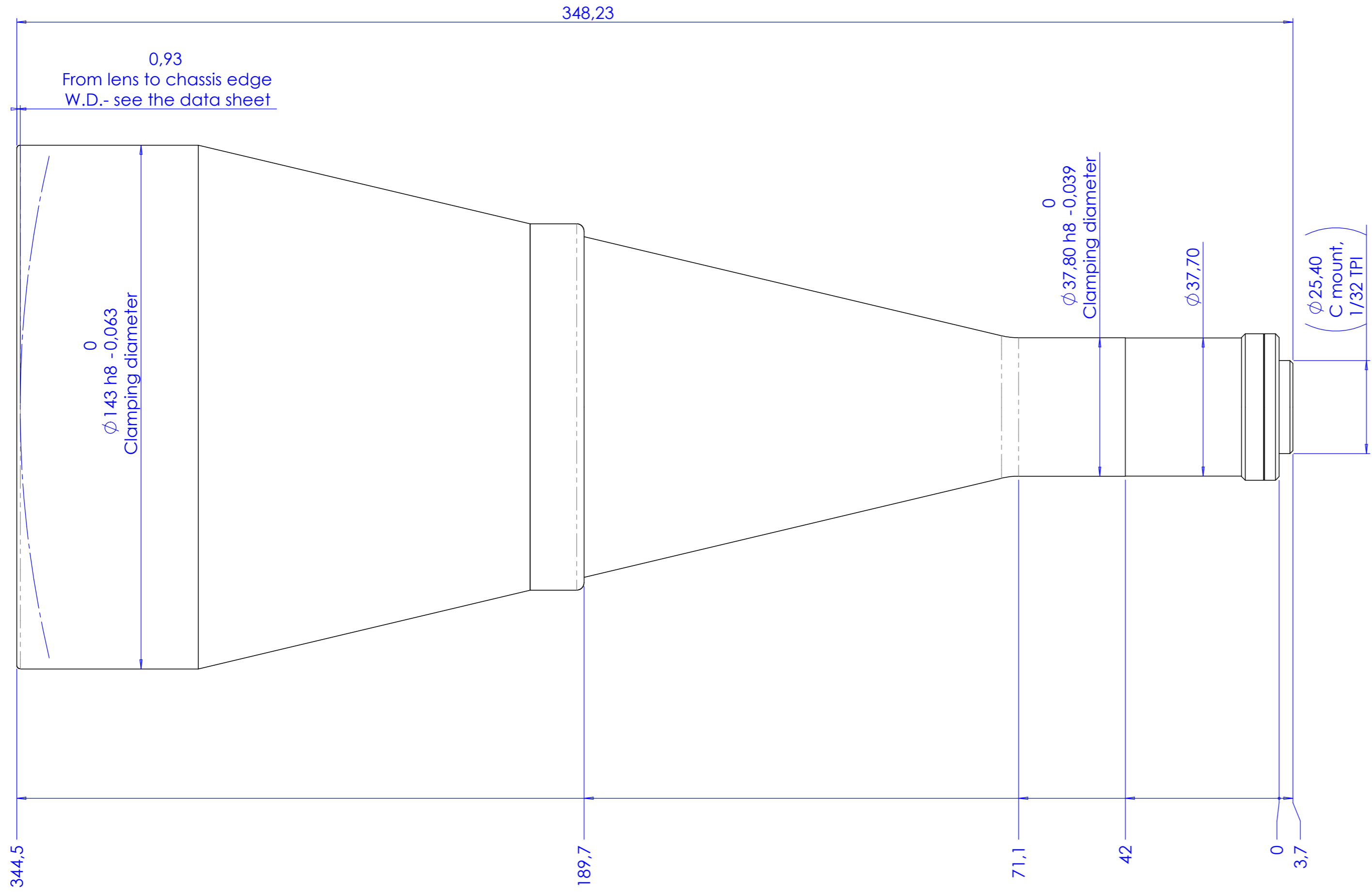

Material	N.A.	Mass	2.5 kg	Scale	1:1
Surface treatment	N.A.	Project-Prod.Item/Instrument		Telecentric lens 23 85	
Geometrical tolerance (ISO 2768-2)		Class	K	Undimensioned bevels	1x45°
Linear tolerance (ISO 2768-2)		Class	m	Undimensioned radii	R 0.5
0.5	>3+	>6+	>30+	>120	>400+
+3	6	30	120	+400	+1000
±0.1	±0.1	±0.2	±0.3	±0.5	±0.8
					±1.2
					±2
Date		Name		Drawing No.	
Designed 12/09/06		A.Vismara		02151-0-B	
Draw 12/01/09		A.Vismara		Sheet 1/1	
Checked X		C.Sedazzari		Reproduction forbidden without specific authorization	
OPTO ENGINEERING S.r.l. - 46100 Mantova Italy - Via Cremona, 29/2 - Tel/fax +39 0376 263525 - e-mail: info@opto-engineering.com - http://www.opto-engineering.com					