

Machine Vision Lens

LE-MV-1614TS

High Resolution Fixed Focal
2/3" 16mm Lens

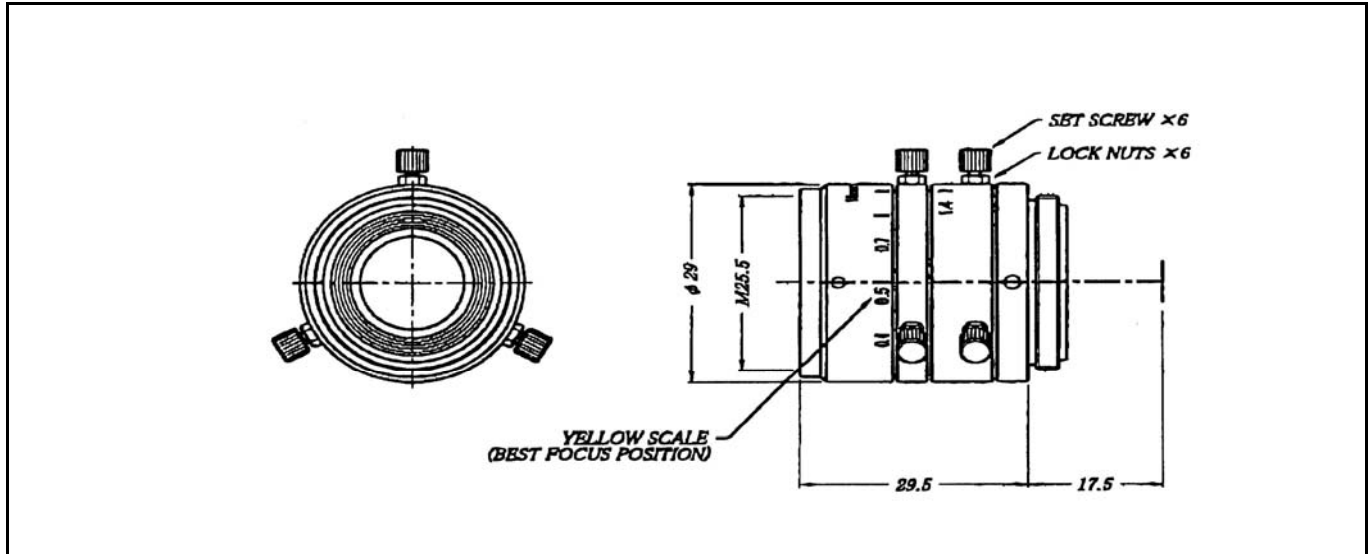

(Unit: mm)

Image Format	2/3-inch
Focal Length	16mm
Max. Aperture	F=1 : 1.4
Iris Operation	Manual with lock
Iris Range	F1.4 - 16
View Angle	Horizontal: 30° 75 Vertical: 23° 31 Diagonal: 37° 94
Lens Mount	C-mount
MOD(Minimum Object Distance)	0.25m
Back Focal Length	12.78mm
Filter Screw Size	25.5mm P=0.5
Dimensions	φ 29mm x 29.5mm
Weight	42g
TV Distortion	On 2/3" CCD : -0.28%