

FORGE 1GigE IP67

Industrial Machine Vision Camera | FG-PGE-50S5M-C-IP / FG-PGE-50S5C-C-IP

KEY FEATURES

IP67 Protection

New Forge 1GigE camera series with IP67 cylindrical enclosure ensures easy integration, simplified cleaning, and protection from dust and water up to 1 meter.

Markets & Applications

Built for harsh environments, the Forge 1GigE IP67 cameras excel in smart agriculture and food applications, with auto-brightness (AGC and Auto-Exposure) for variable and outdoor lighting.

Additional Capabilities

With advanced machine vision features, the Forge 1GigE IP67 cameras include IEEE1588 for multi-camera sync and Lossless Compression (LLC) for higher frame rates and reduced bandwidth, optimizing output without sacrificing image quality.

APPLICATIONS

- Food and Beverage
- Automotive
- Precision Agriculture
- Pulp and Paper
- ITS / Traffic Enforcement

Versatile, Robust, and Cost Effective

The Forge® 1GigE IP67 series offers affordable, easy-to-use GigE Vision cameras designed for industrial imaging with IP67 ingress protection and robust data capture. Ideal for users seeking a 1GigE performance upgrade, Forge 1GigE offers a compact IP67 body, multiple resolutions (1.2 - 12MP), and lower deployment costs.

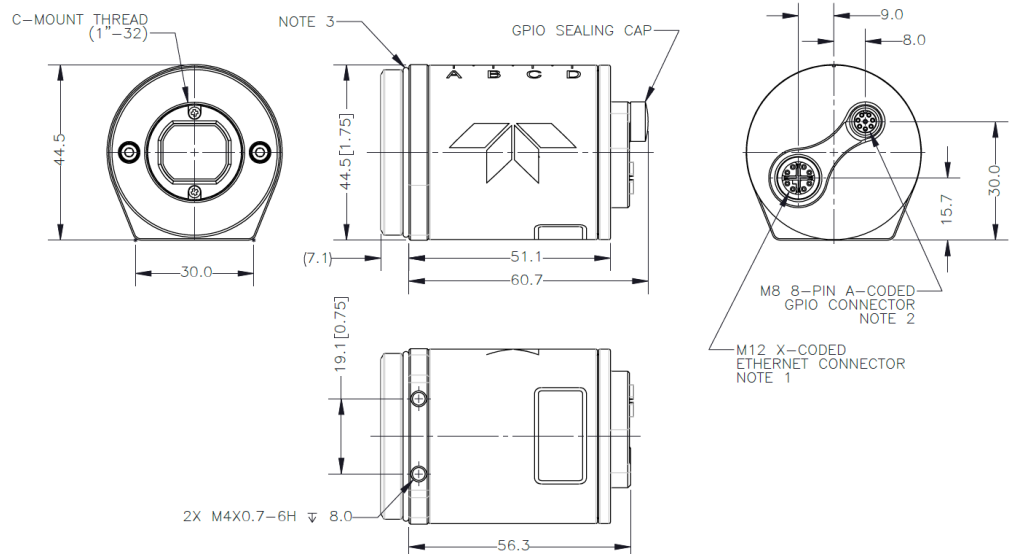

SPECIFICATIONS

	FG-PGE-50S5M-C-IP	FG-PGE-50S5C-C-IP
Resolution	2448 x 2048	
Frame Rate	24 fps	
Megapixels	5.0 MP	
Sensor Model	Sony IMX264	
Sensor Size	2/3"	
Readout Method	Global shutter	
Pixel Size	3.45 µm	
Spectrum	Mono	
Lens Mount	C-mount	
ADC	12-bit	
Minimum Frame Rate*	1 fps	
Gain Range	0 – 47 dB	
Exposure Range*	27 µs to 30 seconds	
Acquisition Modes	Continuous, Single Frame, Multi Frame	
Partial Image Modes	Pixel binning, decimation, ROI	
Image Processing	Gamma, lookup table, sharpness	Color correction matrix, gamma, lookup table, saturation, sharpness
Image Buffer	240 MB	
User Sets	2	
Flash Memory	6 MB (for user-defined data)	
Opto-isolated I/O	1 input, 1 output (on an IP-rated I/O connector)	
Non-isolated I/O	1 bi-directional, 1 input (on an IP-rated I/O connector)	
Serial Port	Supported (on an IP-rated I/O connector)	
Auxiliary Output	3.3 V 120 mA	
Interface	1 Gigabit Ethernet (on an IP-rated I/O connector)	
Power Requirements	Power over Ethernet (PoE) or externally powered over GPIO (12 - 24 V)	
Power Consumption	3.3 W maximum PoE / 2.3 W maximum GPIO	
Dimensions / Mass	55 mm x 45 mm x 45 mm (without optics) / 132 g	
Machine Vision Standard	GigE Vision v1.2	
Compliance	CE, FCC, KCC, RoHS, REACH. The ECCN for this product is: EAR099	
Temperature	Operating: 0°C to 50°C / Storage: -30°C to 60°C	
Humidity (no condensation)	Operating: 20% - 85% / Storage: 20% - 95%	
Warranty	3 Years	

*Values are the same in binning and no binning modes

FOR MORE INFORMATION CONTACT:

THE AMERICAS
 T: +1 866.765.0827 (toll free)
 T: +1 604.242.9937
 E: mv-sales@teledyne.com

**EUROPE, MIDDLE EAST,
 & AFRICA**
 T: +49 7141 488817-0
 F: +49 7141 488817-99
 E: mv-eusales@teledyne.com

CHINA BEIJING OFFICE:
 T: +86-10-84669678 ex. 8019

SHANGHAI OFFICE:
 T: +86-21-32501002 ex. 801
 E: mv-chinasales@teledyne.com
 E: mv-taiwansales@teledyne.com

JAPAN AND ASIA PACIFIC
 T: +81-3-5422-7866
 E: mv-japansales@teledyne.com

This document does not contain information whose export/transfer/disclosure is restricted by the Canadian Export Control regulation. Teledyne FLIR reserves the right to make changes at any time without notice.
 © 2024 Teledyne FLIR

Revision Date: 2025 03 13