

Spyder2 S2-2x-04K40

Line Scan Cameras



Key Features

- 4096 resolution
- 10 μm pixel pitch
- High responsivity
- Base Camera Link™
- 8 or 10 bit selectable output
- Single 12 V to 15 V power supply
- Compact design

Programmability

- Programmable pixel to pixel correction
- Adjustable analog and digital gain
- Analog and digital offset control
- Adjustable integration time and line rate
- Test pattern, line statistics, and camera diagnostics

Typical Applications

- FPD inspection
- PCB inspection
- Postal sorting
- Web inspection
- Print/wood/steel inspection

Overview

4096 pixels, 40 MHz throughput and all of the power and cost effectiveness of the Spyder2 camera family.

The Spyder2 is a small, fast, and cost effective camera boasting a full feature set and a Camera Link™ interface. The Spyder2 has impressive responsivity and programmability and offers precise control over key performance variables such as gain and offset. The 4k Spyder2 uses two taps to deliver a line rate of 9 kHz, providing you with the throughput your application requires with no compromise to image quality.

In addition to its high performance and affordability, the Spyder2 4k also incorporates unique features such as flat field correction and CDS (Correlated Double Sampling) which are typically found in scientific grade cameras. Readily available standard lens options (M72 x 0.75 and F mount) are available.

Specifications

Resolution	4096
Data Rate	40 MHz
Max. Line/Frame Rate	9 kHz
Pixel Size	10 μm
Data Format	8, 10 bit
Output	Base Camera Link
Lens Mount	M72 x 0.75, F mount
Responsivity	76 DN/(nJ/cm ²) @ 10 dB
Dynamic Range	54 dB
Nominal Gain Range	± 10 dB
Size	85 mm x 85 mm x 53.8 mm
Mass	<450 g
Operating Temp	10 °C to 50 °C
Power Supply	12 V to 15 V
Power Dissipation	7 W
Regulatory Compliance	CE
Control	MDR26 Camera Link
Data	Shared with Control
Power	Hirose HR10 6 pin
Example Part Number	S2-20-04K40

Spyder2 S2-2x-04K40

Line Scan Cameras

The Spyder2 is powerful and versatile, yet very cost effective.

The 4k model is our highest resolution Spyder2 camera.

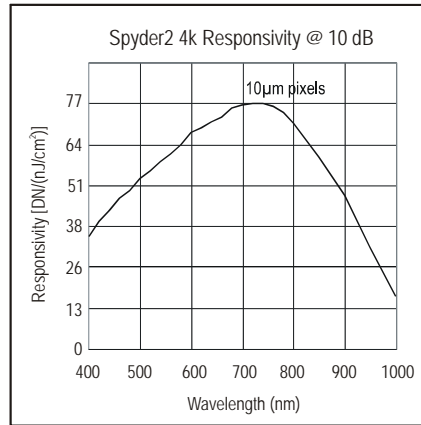

WITH LARGE FORMAT ADAPTER

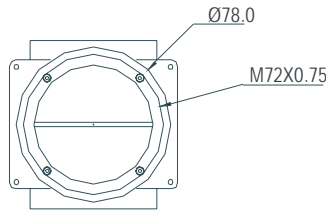
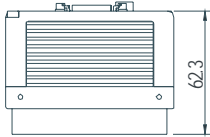

WITH F MOUNT

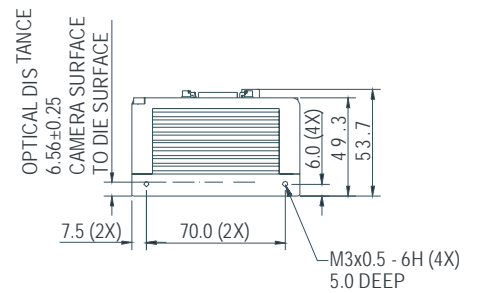
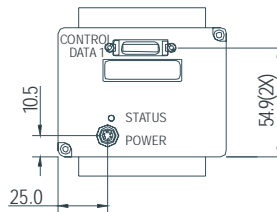
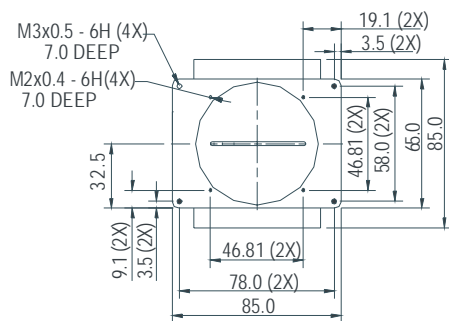
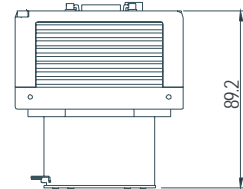

All units in mm.



Worldwide Sales, 605 McMurray Rd., Waterloo, Ontario, Canada N2V 2E9 Tel: 1.519.886.6000 sales.americas@dalsa.com

European Sales, Breslauer Str. 34, D-82194 Gröbenzell (Munich), Germany Tel: 49.8142.46770 sales.europe@dalsa.com

Asia Pacific Sales, Ikebukuro East 13F, 3-4-3 Higashi-Ikebukuro, Toshimo-ku, Tokyo, 170-0013, Japan Tel: 81.3.5960.6353 sales.asia@dalsa.com

25-Jan-06
03-70-00303-00
www.dalsa.com