

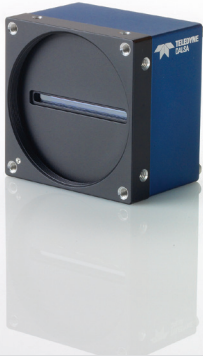

Piranha4 Color Trilinear 4K and 2K

High Speed Trilinear CMOS Cameras



70 kHz line rates trilinear color, superior image quality, and easy to use.

The new Piranha4 trilinear color cameras provide industry leading speeds to meet future requirements of higher throughput in demanding color imaging applications.

Based on Teledyne DALSA's unique CMOS linescan technology, the Piranha4 color family delivers superb color fidelity, large and responsive pixels, all in a compact footprint and with an easy to use interface. New features include multiple regions of interest for data reduction and regional calibration, sub-pixel line spacing correction, factory calibration to white LED, white balance and colour calibration tools.

Key Features

- High speed: up to 70 kHz line rates
- Three native colors (RGB) per pixel
- Combination of various pixel sizes and resolutions
- Bi-directional
- Compact camera body
- Sub-pixel line spacing correction

Programmability

- Multiple Regions of Interest for calibration and data reduction
- 8, 10, or 12 bit output
- Flat field and lens shading correction
- 8 programmable coefficient sets
- GenICam or ASCII compliant interfacing

Typical Applications

- 100% print inspection (pharmaceuticals, bank note)
- Electronics inspection
- Materials grading systems
- Web inspection
- High performance color sorting systems
- Food inspection
- General purpose machine vision

Specifications

Resolution	4096* x 3 and 2048** x 3 pixels
Line Rate	Up to 70 kHz
Pixel Size	10 μm x 10 μm and 14 μm x 14 μm
Data Format	8, 10, or 12 bit, selectable
Output	Base, Medium, Full and Deca Camera Link
Lens Mount	M58 x 0.75 (4k) and M42 x 1 (2k) F-mount adapter available
Responsivity	See graph
Dynamic Range	> 60 dB
Nominal Gain Range	1x to 10x
Size	62 mm x 62 mm x 48 mm
Mass	< 340 g
Operating Temp	0 °C to 65 °C (front plate)
Power	Hirose 6-pin male
Power Dissipation	< 12 W
Control & Data	SDR-26 mini Camera Link
Regulatory Compliance	CE, FCC, and RoHS

Piranha4 Trilinear Model Comparison

Part Number	Resolution	Maximum Line	Pixel Size
P4-CC-04K07T-00-R	4096 x 3 pixels	70 kHz	10 μm x 10 μm
P4-CC-02K07T-00-R	2048 x 3 pixels	70 kHz	14 μm x 14 μm

*The P4-CC-04K07T-00-R camera has been designed to output 4096 pixels of RGB data. However, due to a limitation of the sensor, the output is limited to 4080 pixels for the camera's initial release. This restriction will be resolved in a future release. Details of when the full 4096 pixel cameras will be available can be obtained from your Teledyne DALSA Key Account Manager.

**Scheduled for release Q3 2013



Piranha4 Color Trilinear 4K and 2K

High Speed Trilinear CMOS Cameras

Fast and vibrant. The new Piranha4 cameras are the next step in the evolution of color line scan cameras.

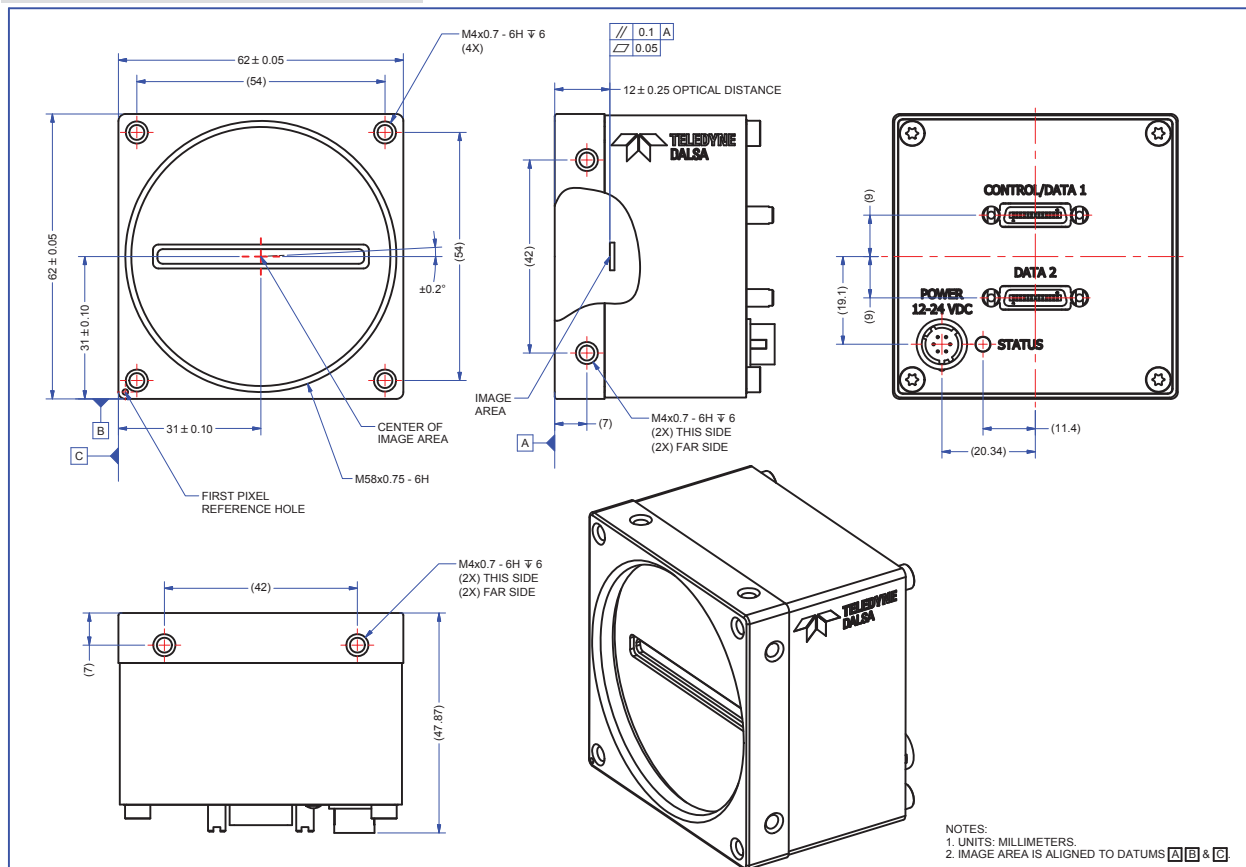
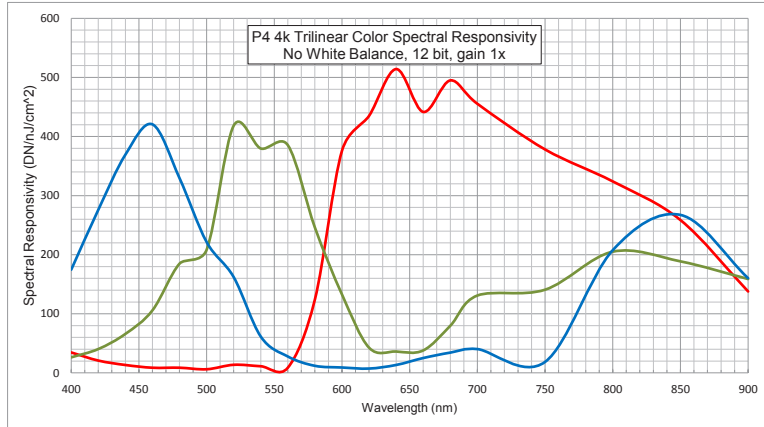

www.teledynedalsa.com

Americas

Boston, USA
 +1 978-670-2000
sales.americas@teledynedalsa.com

Europe

Krailling, Germany
 +49 89-89-54-57-3-80
sales.europe@teledynedalsa.com

Asia Pacific

Tokyo, Japan
 +81 3-5960-6353
sales.asia@teledynedalsa.com

Shanghai, China
 +86 21-3368-0027
sales.asia@teledynedalsa.com