

hr342CXGE

HR 10 GigE



The HR 10 GigE series with its high-end high-resolution CCD and CMOS sensors permits making full use of the sensor bandwidth. 10 GigE delivers up to 1.1 GB/s of image data with distances up to 100m .

The clean design according to well established standards like GigE Vision, 10 GigE Vision and GenICam ensure rapid integration into the final application. The camera features a rich choice of industrial hardware and software features. Burst mode enables even higher trigger frequencies.

Best suited for applications such as optical metrology, surface control, quality control or monitoring of large areas.

Technical Highlights

- > Defect pixel correction, lens shading correction
- > ROI, LUT, binning, gamma, offset, autoexposure
- > GenICam interface with GenTL driver
- > Integrated multi channel LED strobe controller
- > POE (Power Over Ethernet) single cable option
- > Industrial TTL-24V I/O interface with SafeTrigger, programmable logic functions, sequencer and timer, RS232
- > M58 lens interface (F-Mount optional)

HR Series

hr342CXGE

Resolution [MP]	31.4 MP
Resolution (h x v)	6464 x 4852 px
Frame rate (max.)	35.4 fps
Chroma	color
Interface	10GigE
Sensor	
Sensor	IMX342LQA
Manufacturer	Sony
Sensor type	Area CMOS
Shutter type	global shutter
Sensor size (h x v)	22.3 x 16.74 mm
Optical diagonal	27.88 mm
Sensor format	27.9mm (APS-C)
Pixel size (h x v)	3.45 x 3.45 μm
Camera	
Exposure modes	MANUAL;AUTO;EXTERNAL
Trigger modes	INTERNAL;SOFTWARE;EXTERNAL
Exposure time (min)	19 μs
Exposure time (max)	1 sec (external ∞)
Pixel format / max	bayer8, bayer12 / 12 bit
Gain modes / max	manual, auto / 48 dB
S/N ratio (max)	39.9 dB (dep. on environment)
Dynamic range (max)	70.5 dB (dep. on environment)
Internal memory	512 MB SDRAM, 32 MB Flash
Feature Set	
Manual white balance	yes
Automatic white balance	yes
LUT	yes
Offset	yes
Binning	yes
Image flip	yes
Shading correction	yes (external)
Defect pixel correction	yes
Sequencer	yes
POE	yes (POE+)(optional)
Housing	
Lens mount	M58x0.75
Dimensions (w x h x d)	70 x 70 x 79.8 mm
Weight	400 g
Ambient temperature	-10 to 45 °C
Protection class	IP30
I/O-Interfaces	
Input up to 24V	2 x
Input OPTO	1 x
Output open drain	4 x

Dimensions [mm]

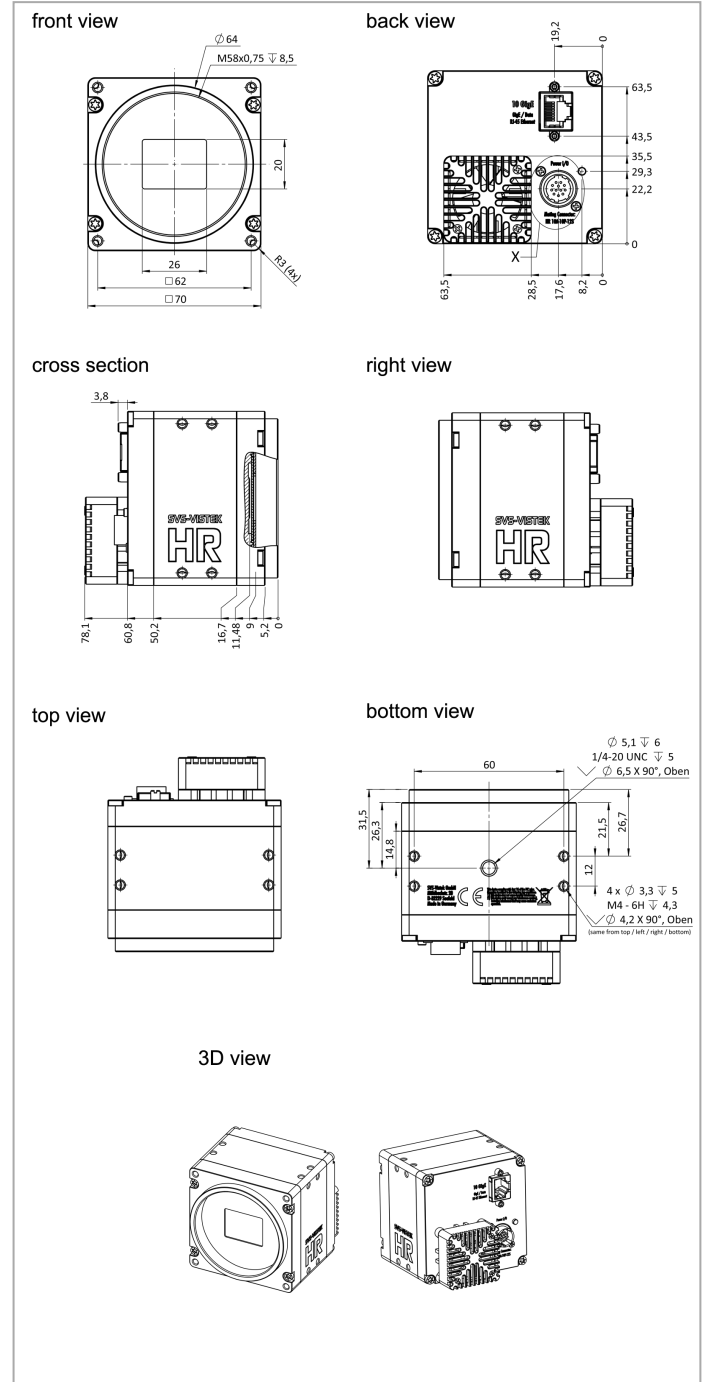

Pinout Mating Connector

Hirose 12 Pin	1	VIN - (GND)	7	OUT 1 (open drain)
	2	VIN + (10 V to 25 V DC)	8	OUT 2 (open drain)
	3	IN 4 (RXD RS232)	9	IN 3 + (opto In +)
	4	OUT 4 (TXD RS232)	10	IN 3 - (opto In -)
	5	IN 1 (0-24V)	11	OUT 3 (open drain)
	6	IN 2 (0-24V)	12	OUT 0 (open drain)

Spectral Response *

I/O RS-232

1 x

Power supply

10 to 25 V (DC)

Power consumption

15.5 W (dep. on operating mode)

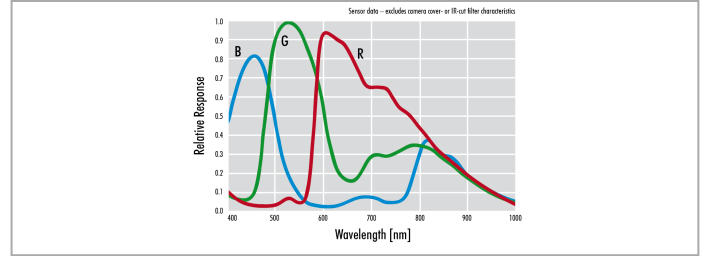

* Sensor data - excludes camera cover- or IR-cut filter characteristics