

❖ **SW-2005TL-CXP**  
❖ **SW-2005M-CXP**  
Compact CMOS line scan camera

■ 3 x 2048 pixels  
■ 1 x 2048 pixels

■ 44 kHz  
■ 172 kHz

Sweep Series  

**CoaXPress**<sup>®</sup>



- **Compact and light weight line scan camera**
- **CoaXPress v2.0 standard with CXP-6 speed (6.25 gigabits per second)**
- **SW-2005TL-CXP: 3 x 2048 pixel output up to 44 kHz**
- **SW-2005M-CXP: 1 x 2048 pixel output up to 172 kHz**
- **14.336mm wide sensor with 7  $\mu$ m x 7  $\mu$ m pixels**
- **Supports direct encoder connection to camera, with the ImageOutputDelay function**
- **Large variety of trigger options**
- **PRNU, DSNU, Master and Individual Gain mode\*, Common and Individual Exposure Mode\*, White Balance\*, Shading**
- **LUT, Color Space Conversion\*, Spatial Compensations\*, Horizontal Binning**
- **8/10/12-bit output**
- **Excellent shock and vibration resistance**
- **Accepts power over CoaXPress interface**
- **C-mount lens mount**

*\*Supported only on SW-2005TL-CXP.*

# Specifications for SW-2005TL-CXP / SW-2005M-CXP

# Sweep Series

Specifications	SW-2005TL-CXP / SW-2005M-CXP
Scanning system	SW-2005TL-CXP: Trilinear CMOS line scan SW-2005M-CXP: Monochrome CMOS line scan
Active pixels	SW-2005TL-CXP: 2048 x 3 pixels (R, G, B) SW-2005M-CXP: 2048 x 1 pixels
Line rate (when Width = 2048)	SW-2005TL-CXP: Up to 44 kHz, variable SW-2005M-CXP: Up to 172 kHz, variable
Sensor width	14.336 mm
Pixel size	7.0 μm x 7.0 μm
Video output	SW-2005TL-CXP: RGB8, RGB10, RGB12 SW-2005M-CXP: Mono8, Mono10, Mono12
Trigger Inputs	2 TTL In, 1 Opto In, 1 CXP In, Software, 4 Pulse Generators, 4 Logic Blocks, 1 Encoder Trigger
Outputs	2 TTL Out
Gain SW-2005TL-CXP	Master Mode: DigitalAll 0dB + 30dB, Digital RB -7.9dB + 12dB Individual Mode: DigitalGBR 0dB + 36dB
Gain SW-2005M-CXP	DigitalAll 0dB + 36dB
Gamma	0.45 to 1.0 (9 steps) or 256-point LUT
Image processing	PRNU/DSNU, black level, white balance*, shading, chromatic aberration*, spatial compensation*
Color space conversion*	RGB to XYZ (CIE) or Color correction matrix
Exposure modes	Off, Timed, and TriggerWidth
Exposure time** (ExposureMode = Timed)	SW-2005TL-CXP: 3.22 μs ~ 15.148 ms SW-2005M-CXP: 1.65 μs ~ 15.148 ms step: 0.01 μs; Exposure time can be longer at slower line rates.
Trigger width control	SW-2005TL-CXP: 3.22 μs ~ 1 sec SW-2005M-CXP: 1.65 μs ~ 1 sec
Interface	Connector: Micro-BNC, CoaXPress v2.0, CXP-6 Link Configs: CXP-6_X1, CXP-3_X1
Lens mount	C-mount (back flange distance 17,526 mm)
Operating temp. (ambient)	0°C to +45°C (20 to 80% non-condensing)
Storage temp. (ambient)	-25°C to +60°C (20 to 80% non condensing)
Vibration	10G (20 Hz to 200 Hz, XYZ directions)
Shock	80G
Regulations	CE (EN55032, EN55035) FCC Part15 Subpart B, RoHS/WEEE, KC
Power SW-2005TL-CXP	12-pin: 10.8V to 26.4V, 4.5W typical @ +12V, 5.6W Max PoCXP: 18.5V to 26V, 4.6W typical, 5.6W Max
Power SW-2005M-CXP	12-pin: 10.8V to 26.4V, 4.3W typical @ +12V, 5.6W Max PoCXP: 18.5V to 26V, 4.4W typical, 5.6W Max
Dimensions (H x W x L)	44 mm x 44 mm x 54 mm (without lens mount protrusions and connectors)
Weight	SW-2005TL-CXP: 154 g; SW-2005M-CXP: 153g

\*Supported only on SW-2005TL-CXP.  
\*\*Exposure Offset Time included.

## Ordering Information

SW-2005TL-CXP SW-2005M-CXP	CMOS trilinear RGB camera CMOS monochrome line scan camera
-------------------------------	---

## Dimensions

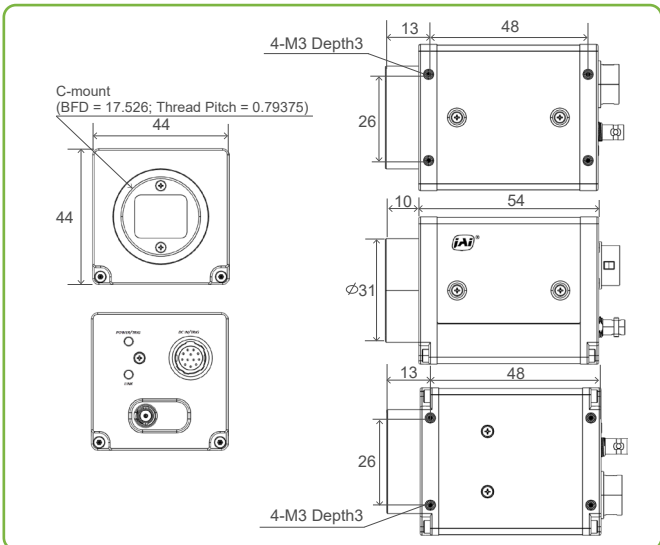

## Connector pin-out

### DC In / Trigger (12-pin)

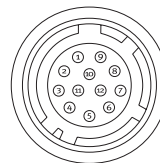

HR10A-10R-12PB(71)

Pin	1	Ground
2	DC in +10.8V to +26.4V	
3	Ground	
4	TTL in 4	
5	Opto in 1-	
6	Opto in 1+	
7	TTL out 4	
8	NC	
9	TTL out 1	
10	TTL in 1	
11	DC in +10.8V to +26.4V	
12	Ground	

## Spectral response

### SW-2005TL-CXP Sensitivity

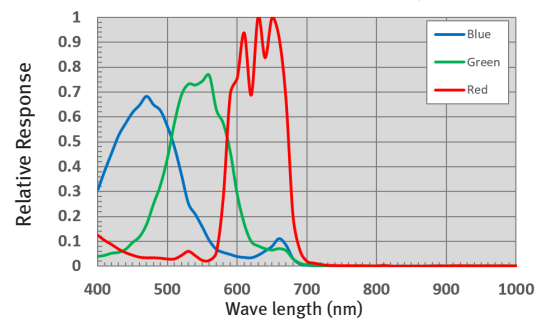

### SW-2005M-CXP Sensitivity

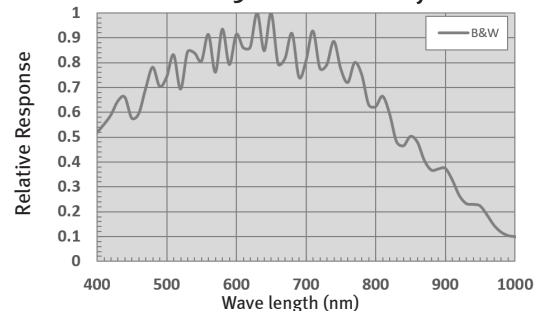

Company and product names mentioned in this datasheet are trademarks or registered trademarks of their respective owners. JAI-A-S cannot be held responsible for any technical or typographical errors and reserves the right to make changes to products and documentation without prior notice.

**Europe, Middle East & Africa**  
Phone +45 4457 8888  
Fax +45 4491 8880

**Asia Pacific**  
Phone +81 45 440 0154  
Fax +81 45 440 0166

**Americas**  
Phone (Toll-Free) 1 800 445 5444  
Phone +1 408 383 0300

