

■ 1456 x 1088

■ 78 fps

Apex Series 

## ❖ AP-1600T-USB

1.6 megapixel CMOS prism area scan

**USB**<sup>TM</sup>  
VISION



- **High resolution prism-based 3CMOS camera**
- **Full spatial resolution and true RGB color values with no interpolation**
- **Individual analog gain and exposure control for R, G, and B channels**
- **Color and edge enhancement functions**
- **On-board RGB to HSI, XYZ, sRGB and Adobe RGB color space conversions**
- **Single and multi-ROI's**
- **RGB video output with 8, 10, or 12-bits per channel\***
- **Compact size and smart design**
- **Excellent shock and vibration resistance**
- **USB3 Vision interface**
- **C-mount lens mount**

\* Some video processing functions not available with 12-bit output

# Specifications for AP-1600T-USB

# Apex Series

Specifications	AP-1600T-USB
Sensor	1/2.9" 3-CMOS global shutter (IMX273)
Active pixels	1456 (h) x 1088 (v) x 3 (R,G,B)
Frame rate, full frame	78.8 frames/sec. @ 8-bit
Active area	5.02 mm (h) x 3.75 mm (v) - 6.27 mm diagonal
Pixel size	3.45 μm x 3.45 μm
System clock	74.25 MHz (for pulse generator)
Read-out modes	Full ROI (single) 1456 (h) x 1088 (v) up to 78.8 fps H: 16 to 1456 pixels in 16 pixel steps V: 2 to 1088 lines in 2 line steps ROI (multi) Binning Up to 5 overlapping scanning areas can be defined. 1X2, 2X1, 2X2
EMVA 1288 Parameters	12-bit output format
Absolute sensitivity	3.72 p (λ = 525 nm)
Maximum SNR	40.68 dB
Traditional SNR*	>60 dB (0 dB gain, 10-bit)
Video signal output	8/10/12-bits per channel† (24/30/36-bit RGB)
Video modes	Normal, Single ROI, Multi ROI, Sequencer
Gain	Manual control - master mode or individual R/G/B channels Auto gain control - off, continuous, one-push
White balance	Off, 4 presets (3200K, 5000K, 6500K, 7500K), or one-push/continuous AWB using gain or exposure time (3000K to 9000K)
Gamma/LUT	0.45 to 1.0 (9 steps) or 257-point programmable LUT
Shading correction	Flat shading, color shading
Trigger input	Opto In (2), Pulse Generators (4), Software, NAND Out (2), User Output (4)
Exposure modes	Timed/EPS, Trigger Width, Auto
Electronic shutter	(can be set independently for R/G/B channels) 16 μs to 8 sec. in 1 μs steps (8-bit) 16 μs to 8 sec. in 1 μs steps (10-bit)
Auto Level Control (ALC)	Shutter range from 100 μs to 13.427 ms, gain range from 0 dB to +12 dB. Tracking speeds and max. values adjustable.
Pre-processing functions	Color enhancer, edge enhancer, color space conversion (RGB to HSI, XYZ, sRGB, Adobe RGB), blemish compensation (200 px/channel)
Operating temp. (ambient)	-5°C to +45°C (20 to 80% non-condensing)
Storage temp. (ambient)	-25°C to +60°C (20 to 80% non condensing)
Vibration	3G (20 Hz to 200 Hz, XYZ directions)
Shock	50G
Regulations	CE (EN61000-6-2, EN61000-6-3) FCC Part 15 Class B, RoHS/WEEE
Power	12-pin USB 3.0 +12V to +24V DC ± 10%. 5.3 W typical @ +12 V Bus power: not supported
Lens mount	C-mount
Dimensions (H x W x L)	44 mm x 44 mm x 74 mm (excl. connectors)
Weight	170 g

Ordering Information	
AP-1600T-USB	3-CMOS prism color camera with USB3 Vision

\*Traditional SNR is based on random noise in a single frame, where EMVA SNR measurements consider more comprehensive noise sources and variance over time.

<b>Europe, Middle East &amp; Africa</b> Phone +45 4457 8888 Fax +45 4491 8880	<b>Asia Pacific</b> Phone +81 45 440 0154 Fax +81 45 440 0166	<b>Americas</b> Phone (Toll-Free) 1 800 445 5444 Phone +1 408 383 0300
---	---	--

Visit our website on [www.jai.com](http://www.jai.com)

## Dimensions

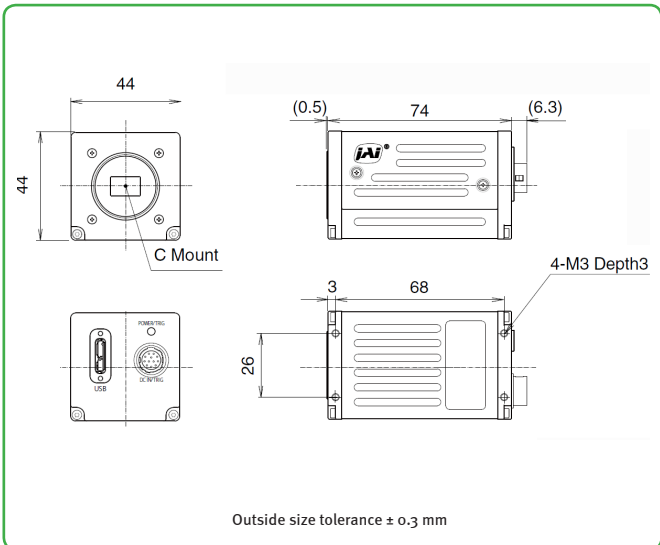

## Connector pin-out

### DC In / Trigger

HIROSE HR10A-10R-12PB(71)

### USB 3.0 Interface

Micro B type - ZX3600-B-10P or equiv.

No.	I/O	Name	Note
1	I	VBUS IN	Power (VBUS)
2	I/O	DM	USB2.0 Differential pair (-)
3	I/O	DP	USB2.0 Differential pair (+)
4		OTG ID	USB OTG ID for identifying lines
5		GND	GND
6	O	FX3 SSTXM	USB3.0 Signal Transmission line (-)
7	O	FX3 SSTXP	USB3.0 Signal Transmission line (+)
8		GND	GND
9	I	FX3 SSRXP	USB3.0 Signal Receiving line (-)
10	I	FX3 SSRXM	USB3.0 Signal Receiving line (+)
11		DC in +12V to +24 V	
12		Ground	

## Spectral response

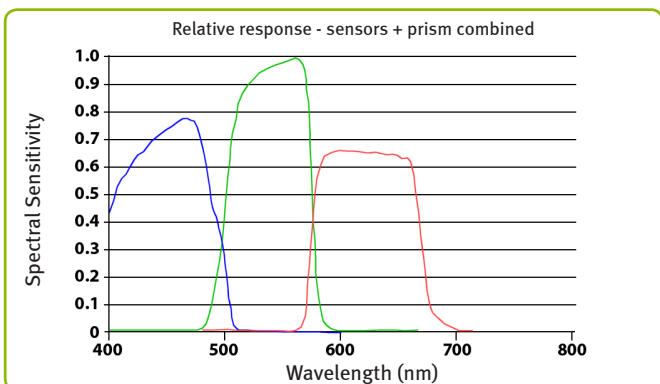

†12-bit output available in video processing bypass mode. See manual for details.

Company and product names mentioned in this datasheet are trademarks or registered trademarks of their respective owners. JAI-A-S cannot be held responsible for any technical or typographical errors and reserves the right to make changes to products and documentation without prior notice.



See the possibilities

March 2018