



*GigE Vision
Digital 3CCD Progressive Scan
RGB Color Camera*

CV-M9GE

Operation Manual

Hardware Part

Camera revision: 0

Manual version: 1.0

- Table of Contents -

1. General.....	3
2. Standard Composition	3
3. Main Features	3
4. Locations and Functions.....	4
5. Pin Assignment.....	5
5.1. 12-pin Multi-connector (DC-in/GPIO/Iris Video).....	5
5.2. Digital Output Connector for Gigabit Ethernet	5
6. GPIO (Inputs and outputs).....	6
6.1. Overview	6
6.1.1. LUT (Look Up Table)	6
6.1.2. 12bit Counter	6
6.1.3. Pulse Generators (0 to 3)	6
6.2. Inputs and outputs table.....	7
6.2.1. Equivalent circuit for TTL 1 and 2 inputs	8
6.2.2. Equivalent circuit for LVDS input	8
6.2.3. Equivalent circuit for TTL IN 3 Input.....	8
6.2.4. Equivalent circuit for TTL OUT 1 and 2 outputs.....	9
6.3. Configuring the GPIO module (register settings)	9
6.3.1. Signal Selector	9
6.3.2. xTTL_LVDS Selector.....	9
6.3.3. 12bit counter	10
6.3.4. Pulse generator (20 bit x 4)	10
6.4 GPIO programming examples	12
6.4.1 Trigger Phase Control	12
6.4.2 Internal Trigger Generator	13
6.4.3 Multi EEN Control with PWC.....	14
7. GigE Vision Streaming Protocol (GVSP)	15
7.1. Digital Video Output (Bit Allocation)	15
7.2. Bit Allocation (Pixel Format / Pixel Type).....	15
7.2.1. GVSP_PIX_BGR10V1_PACKED (32bit)	15
7.2.2. GVSP_PIX_BGR10V2_PACKED (32bit)	15
7.2.3. GVSP_PIX_RGB8_PACKED (24bit).....	15
8. Functions and Operations	16
8.1. GigE Vision Standard Interface	16
8.2. Recommended Network Configurations.....	16
8.2.1 Verified Network Interface Cards (NICs)	16
8.3. Basic functions	17
8.3.1. White Balance (by gain setting)	17
8.3.2. White balance (by individual R, G and B channel shutter settings).....	18
8.3.3. Automatic Dynamic shading correction.....	18
8.3.4. Knee function.....	19
8.3.5. ROI (Region of Interest)	19
8.3.6. Electronic Shutter.....	20
8.3.7. Color bar for test.....	21
8.3.8. Analogue output for Auto Iris Lens	21
8.4. Sensor Layout and timing.....	22
8.4.1. CCD Sensor Layout	22
8.4.2. Horizontal timing.....	23
8.4.3. Vertical timing.....	23
8.4.4. Partial Scanning	24
8.4.5. Vertical binning.....	25
8.5. Operation Modes	27
8.5.1. LVAL synchronous accumulation.....	27

CV-M9 GE

8.5.2. LVAL a-synchronous accumulation.....	29
8.5.3. Continuous operation.....	30
8.5.4. Edge Pre-select Trigger Mode.....	30
8.5.5. Pulse Width Control Trigger Mode.....	32
8.5.6. Sequential Trigger Mode (EPS).....	33
8.5.7. Delayed Readout Mode (EPS, PWC).....	34
8.5.8. Smear-less Mode.....	35
8.6. Operation Mode and Functions matrix.....	36
9. Register Map.....	37
10. External Appearance and Dimensions.....	47
11. Specifications.....	47
11.1. Spectral response.....	47
11.2. Specification table.....	48
12. Appendix.....	49
12.1. Precautions.....	49
12.2. Typical Sensor Characteristics.....	49
12.3. References.....	50
Index.....	51
13. User's Record.....	1

1. General

The CV-M9GE is a digital 3CCD progressive scan RGB color camera with GigE Vision Interface. Based on the GigE Vision standard, the camera is connected to the host computer via a standard Gigabit Ethernet port, without the need for a dedicated frame grabber. This high-speed serial interface that is capable of bridging distances up to 100 meters uses CAT 5e or CAT 6 Ethernet cables. All Gigabit Ethernet infrastructures, such as switches, routers and fiber-optic converters, can be used together with this camera, allowing even longer distances to be bridged.

The camera uses three 1/3" format XGA (1024 x 768 pixel) CCD sensors mounted on a dichroic prism, providing full resolution for each of the Red, Green and Blue color bands. The compact 3CCD C-mount prism unit is designed for the highest color fidelity. A built-in shading correction greatly reduces chromatic shading, thus widening the choice of C-mount lenses that can be used with this camera.

The camera outputs 30 full frames/second as 3 x 8 bit or 3 x 10 bit images in continuous operation. Functions like partial scanning and vertical binning allow even higher frame rates. External trigger can also be applied to the camera, to capture images based on external events.

The CV-M9GE also complies with the GenICam standards, as it has in internal XML file that is used to describe the functions/features of the camera. For further information on GenICam please go to www.emva.org.

As a programming application interface, JAI provides an SDK (Software Development Kit). This SDK includes software documentation, register information, code examples and objects such as Transport Layer and Device Drivers (Optimized Filter Driver and Standard Windows Stack). The JAI SDK Light can be downloaded from www.jai.com

The latest version of this manual can be downloaded from: www.jai.com
For camera revision history, please contact your local JAI distributor.

2. Standard Composition

The standard camera composition consists of the camera main body, C-mount protection cap and tripod mount plate.

3. Main Features

- 3 x 1/3" progressive scan RGB color camera
- 1024 (h) x 768 (v) active area
- 4.65 µm square pixels
- Compact RGB prism for C-mount lenses
- Chromatic shading reduction for wider choice of lenses
- 30 frames/second with full resolution
- 86 frames/second with 1/8 partial scan
- Vertical binning for higher sensitivity and frame rate
- 12 bit internal video processing
- 24 or 30-bit RGB output via GigE Vision
- Edge Pre-Select and Pulse Width Control trigger modes
- Sequential trigger mode for on-the-fly change of shutter, gain and ROI
- Manual, continuous (auto-tracking) or one-push auto white balance
- Color bar test image for set-up
- Comprehensive software suite and SDK (SDK Light) for Windows XP

4. Locations and Functions

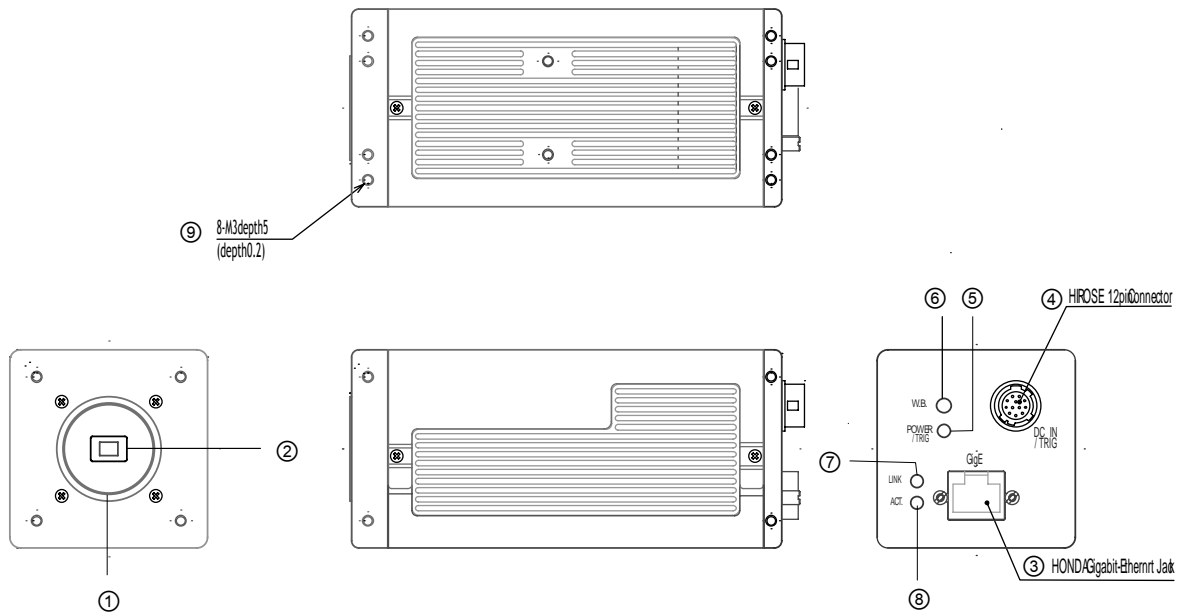

- 1 Lens mount of C-mount type. *1)
- 2 RGB Prism with 3 x 1/3" CCD sensors
- 3 RJ45 GigE Connector
- 4 Hirose 12-pin connector for DC +12V power external sync signals
- 5 LED for power and trigger indication
 - Orange : Initialization after power ON
 - Green : Normal mode
 - Green flashing : Trigger pulse is being input
- 6 Switch for one-push white balance
- 7 LED for GigE network condition: LINK
- 8 LED for GigE network condition: ACT.
- 9 Mounting holes 8 x M3 depth 5mm .

*1) **Note:** Rear protrusion on C-mount lens must be less than 4.0mm

Fig. 1. Locations

5. Pin Assignment

5.1. 12-pin Multi-connector (DC-in/GPIO/Iris Video)

Type: HR10A-10R-12PB-01

(Hirose) male.

(Seen from rear of camera.)

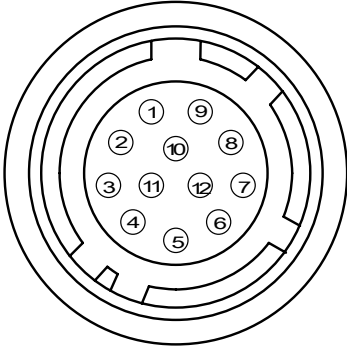

Pin no.	Signal	Remarks
1	GND	
2	+12 V DC input	
3	GND	
4	Iris video	Only for Continuous mode
5	GND	
6	LVDS + / TTL IN 1	GPIO IN/OUT
7	LVDS - / TTL IN 2	
8	TTL OUT 1	
9	TTL OUT 2	
10	TTL IN 3	
11	+12 V DC input	
12	GND	

Fig. 2. 12-pin connector.

5.2. Digital Output Connector for Gigabit Ethernet

RJ-45 Connector

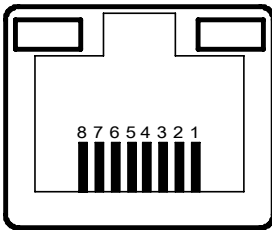

Fig 3. Gigabit Ethernet connector

Pin No	In/Out	Name
1	In/Out	MX1+ (DA+)
2	In/Out	MX1- (DA-)
3	In/Out	MX2+ (DB+)
4	In/Out	MX3+ (DC+)
5	In/Out	MX3- (DC-)
6	In/Out	MX2- (DB-)
7	In/Out	MX4+ (DD+)
8	In/Out	MX4- (DD-)

6. GPIO (Inputs and outputs)

6.1. Overview

All input and output signals pass through the GPIO (General Purpose Input and Output) module. The GPIO module consists of a Look-Up Table (LUT - Cross-Point Switch), 4 Pulse Generators and a 12-bit counter. In the LUT, the relationship between inputs, counters and outputs is governed by internal register set-up.

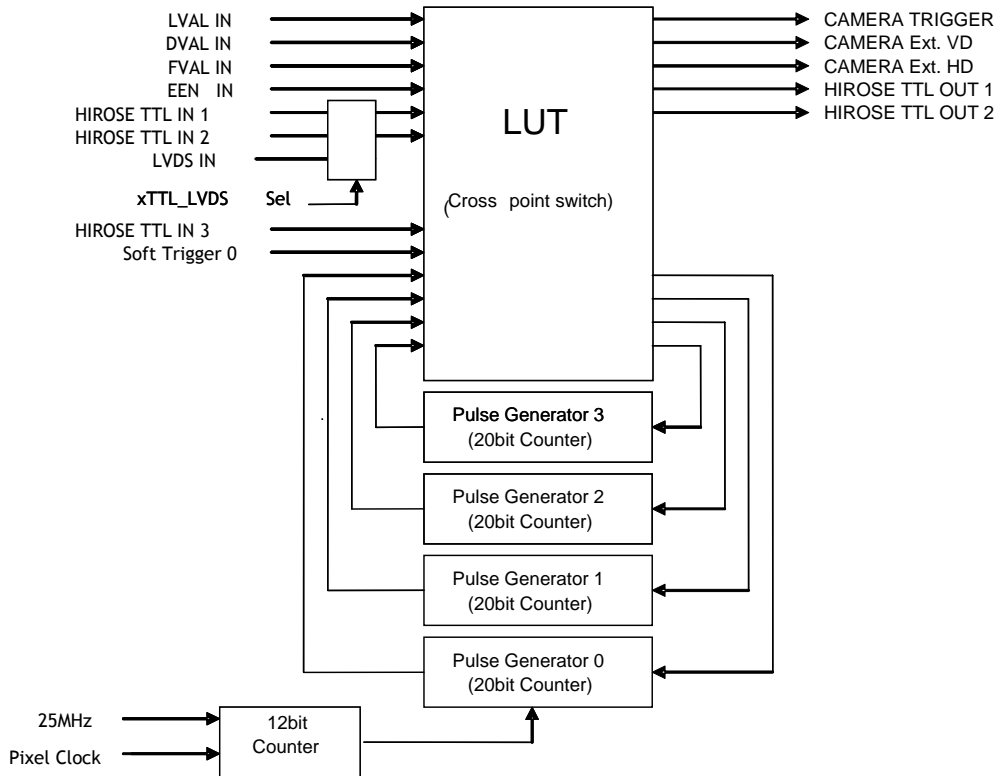

The blocks shown in the above diagram have the following functionality:

6.1.1. LUT (Look Up Table)

The LUT works as a cross-point switch which allows connecting inputs and outputs freely. The signals LVAL_IN, DVAL_IN, FVAL_IN and EEN_IN all originate from the camera timing circuit. The signal CAMERA_TRIGGER is connected to the camera timing circuit, allowing a hardware trigger.

6.1.2. 12-bit Counter

A 25MHz clock or the camera pixel clock can be used as a source. The counter has a “Divide by N”, where N has the range 1 through 4096, allowing a wide range of clock frequencies to be programmed.

6.1.3. Pulse Generators (0 to 3)

Each pulse generator consists of a 20bit counter. The behavior of these signals is defined by their pulse width, start point and end point.

The pulse generator signals can be set in either triggered or periodic mode.

In triggered mode, the pulse is triggered by the rising edge/falling edge/high level or low level of the input signal.

In periodic mode, the trigger continuously generates a signal that is based on the configured pulse width, starting point and endpoint.

6.2. Inputs and outputs table

Signals	I/O	Description	diagram
LVAL_IN	I	LVAL (Line Valid) from camera timing circuit (See chapter 8.4 for timing relationship)	
DVAL_IN	I	DVAL from camera	
FVAL_IN	I	FVAL (Frame Valid) from camera timing circuit (See chapter 8.4 for timing relationship)	
EEN_IN	I	EEN (Exposure Enable) from camera timing circuit. (See chapter 8.4 for timing relationship)	
HIROSE_TTL_IN1	I	TTL input on pin 6 of Hirose 12-pin. Active when TTL is selected by xTTL_LVDS Sel	Fig. 4
HIROSE_TTL_IN2	I	TTL input on pin 7 of Hirose 12-pin. Active when TTL is selected by xTTL_LVDS Sel	Fig. 4
LVDS_IN	I	LVDS signal input on Hirose connector LVDS + Pin 6 / LVDS - Pin 7 Active when LVDS is selected by xTTL_LVDS Sel	Fig. 5
HIROSE_TTL_IN3	I	TTL input on pin 10 of Hirose 12-pin.	Fig. 6
Soft_Trigger_0	I	Software trigger input from Ethernet Refer to GPIO module register xx	
Pulse Generator out 0	I	Pulse Generator 0 output	
Pulse Generator out 1	I	Pulse Generator 1 output	
Pulse Generator out 2	I	Pulse Generator 2 output	
Pulse Generator out 3	I	Pulse Generator 3 output	
CAMERA TRIGGER	O	Trigger signal to camera timing circuit.	
HIROSE TTL OUT 1	O	TTL output on Pin 8 of Hirose 12-pin	Fig. 7
HIROSE TTL OUT 2	O	TTL output on Pin 9 of Hirose 12-pin	Fig. 7
Pulse Generator in 0	O	Pulse Generator 0 Clear input	
Pulse Generator in 1	O	Pulse Generator 1 Clear input	
Pulse Generator in 2	O	Pulse Generator 2 Clear input	
Pulse Generator in 3	O	Pulse Generator 3 Clear input	

6.2.1. Equivalent circuit for TTL 1 and 2 inputs

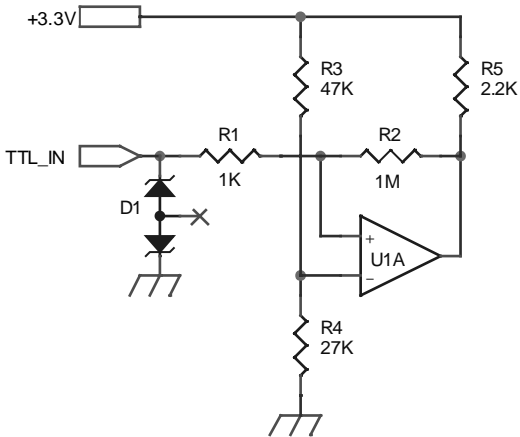

This circuit is for TTL IN 1 and TTL IN 2 through pins 6 and 7 at the 12-pin Hirose connector. It is a DC-coupled input. See GPIO selector for setting this input (TTL or LVDS)

Fig.4 Hirose TTL IN (1 and 2) equivalent circuit

6.2.2. Equivalent circuit for LVDS input

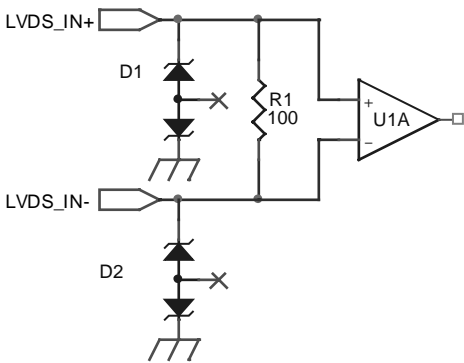

This circuit is for LVDS IN - and + through pins 6 and 7 at the 12-pin Hirose connector. See GPIO selector for setting this input (TTL or LVDS)

Fig.5 LVDS IN equivalent circuit

6.2.3. Equivalent circuit for TTL IN 3 Input

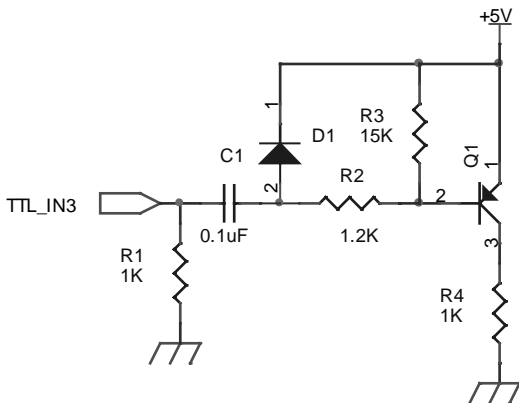

This circuit is for TTL IN 3 through pin 10 at the 12-pin Hirose connector. This circuit is AC coupled.

Fig.6 Hirose TTL IN 3 equivalent circuit

6.2.4. Equivalent circuit for TTL OUT 1 and 2 outputs

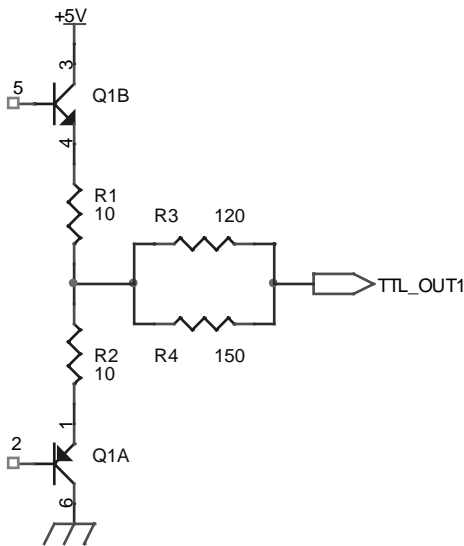

This circuit is for TTL OUT 1 and 2 through pins 8 and 9 at the Hirose 12-pin connector. The output is sent from a 75 ohm source which is a complementary Emitter-follower circuit. The supply voltage for this circuit is 5V.

Fig.7 Hirose TTL OUT equivalent circuit

6.3. Configuring the GPIO module (register settings)

6.3.1. Signal Selector

Address	Internal Name	Access	Size	Value (Range)
0xB058	CAMERA TRIG Selector	R/W	4	GPIO Selector: 0x00:CAMERA LVAL IN 0x01:CAMERA DVAL IN 0x02:CAMERA FVAL IN 0x03:CAMERA EEN IN 0x04:HIROSE TTL IN 1 0x05:HIROSE TTL IN 2 0x06:HIROSE TTL IN 3 0x07:HIROSE LVDS IN 0x09:SOFT TRIG 0 0x0D:Pulse Generator 0 0x0E:Pulse Generator 1 0x0F:Pulse Generator 2 0x10:Pulse Generator 3 0x7F:No Connect
0xB05C	CAMERA Ex. VD Selector	R/W	4	
0xB060	CAMERA Ex. HD Selector	R/W	4	
0xB064	HIROSE TTL OUT 1 Selector	R/W	4	
0xB068	HIROSE TTL OUT 2 Selector	R/W	4	
0xB06C	Pulse Generator 0 Selector	R/W	4	
0xB070	Pulse Generator 1 Selector	R/W	4	
0xB074	Pulse Generator 2 Selector	R/W	4	
0xB078	Pulse Generator 3 Selector	R/W	4	
				Add 0x80 will result in low active output.

6.3.2. xTTL_LVDS Selector

Address	Internal Name	Access	Size	Setting Value (and range)
0xA8B0	xTTL_LVDS Select	R/W	4	0x00 : TTL In 1, TTL In 2 Active 0x01 : LVDS In Active

6.3.3. 12-bit counter

Address	Internal Name	Access	Size	Setting Value (and range)
0xB000	Clock source	R/W	4	0: 25MHz 1: Pixel Clock
0xB004	Divide by N	R/W	4	0x000: N=1 0x001: N=2 0x002: N=3 0xFFF: N=4096

6.3.4. Pulse generator (20 bit x 4)

There are 4 pulse generators (designated 0 through 3) that can be used to create various timing scenarios by programming start point, endpoint, length and repeats.

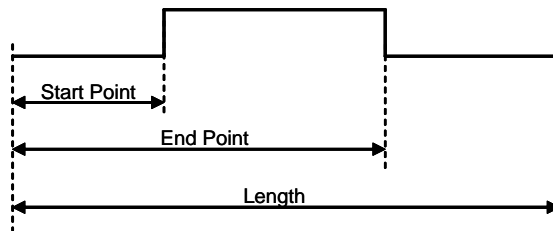

Address	Internal Name	Access	Size	Setting Value (and range)
0xB008	Length Counter 0	R/W	4	0x00001 to 0xFFFFF
0xB00C	Start point Counter 0	R/W	4	0x00000 to 0xFFFFF
0xB010	Repeat Count 0	R/W	4	0x00: infinite 0x01: 1 time 0xFF: 255 times
0xB014	End point Counter 0	R/W	4	0x00001 to 0xFFFFF
0xB018	Counter Clear 0	R/W	4	0: Free Run 1: High Level Clear 2: Low Level Clear 4: Rising Edge Clear 8: Falling Edge Clear
0xB01C	Length Counter 1	R/W	4	0x00001 to 0xFFFFF
0xB020	Start point Counter 1	R/W	4	0x00000 to 0xFFFFF
0xB024	Repeat Count 1	R/W	4	0: Infinite 1: 1 time 255: 255 times
0xB028	End point Counter 1	R/W	4	0x00001 to 0xFFFFF
0xB02C	Counter Clear 1	R/W	4	0x00: Free Run 0x01: High Level Clear 0x02: Low Level Clear 0x04: Rising Edge Clear 0x08: Falling Edge Clear
0xB030	Length Counter 2	R/W	4	0x00001 to 0xFFFFF
0xB034	Start point Counter 2	R/W	4	0x00000 to 0xFFFFF

CV-M9 GE

Address	Internal Name	Access	Size	Setting Value (and range)
0xB038	Repeat Count 2	R/W	4	0x00: Infinite 0x01: 1 time 0xFF: 255 times
0xB03C	End point Counter 2	R/W	4	0x00001 to 0xFFFFF
0xB040	Counter Clear 2	R/W	4	0x00: Free Run 0x01: High Level Clear 0x02: Low Level Clear 0x04: Rising Edge Clear 0x08: Falling Edge Clear
0xB044	Length Counter 3	R/W	4	0x00001 to 0xFFFFF
0xB048	Start point Counter 3	R/W	4	0x00000 to 0xFFFFF
0xB04C	Repeat Count 3	R/W	4	0x00: Infinite 0x01: 1 time 0xFF: 255 times
0xB050	End point Counter 3	R/W	4	0x00001 to 0xFFFFF
0xB054	Counter Clear 3	R/W	4	0x00: Free Run 0x01: High Level Clear 0x02: Low Level Clear 0x04: Rising Edge Clear 0x08: Falling Edge Clear

6.4 GPIO programming examples

6.4.1 Trigger Phase Control

100clock delay to the input Trigger

Address	Register	Value
0xA040	Trigger Mode	1 = EPS(Edge pre-select)
0xB000	Clock Choice	1 = Pixel Clock
0xB004	Counter Dividing Value	0 = Pass through
0xB008	Length Counter 0	1000 Clocks
0xB00C	Start point Counter 0	100 Clocks
0xB010	Repeat Count 0	1
0xB014	End point Counter 0	500 Clocks
0xB018	Counter Clear 0	4 = Rising Edge Clear
0xB058	CAMERA TRIG Selector	13 = pulse generator 0
0xB06C	Pulse Generator 0 Selector	4 = HIROSE TTL In 1

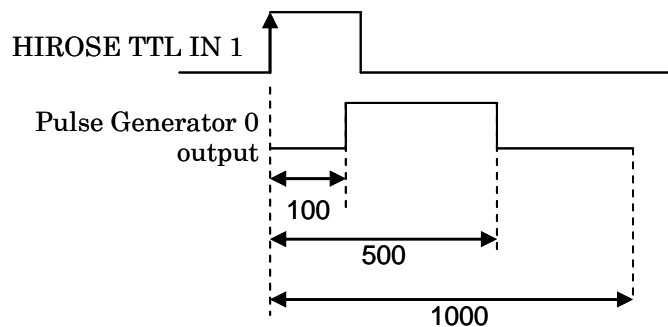
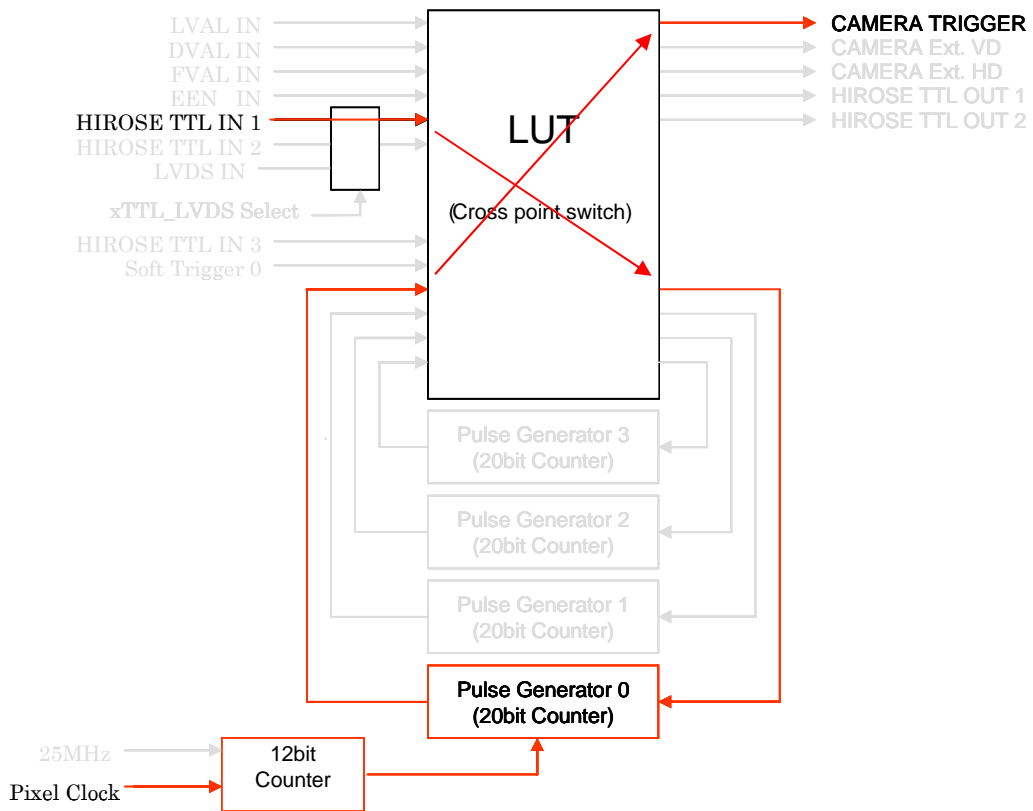

Pulse Generator 0 timing

6.4.2 Internal Trigger Generator

Create a trigger signal and trigger the camera

Address	Register	Value
0xA040	Trigger Mode	1 = EPS
0xB000	Clock Choice	1 = Pixel Clock
0xB004	Counter Dividing Value	963 = 1/964 dev(Line Rate)
0xB008	Length Counter 0	1000 Clocks
0xB00C	Start point Counter 0	100 Clocks
0xB010	Repeat Count 0	0 = Free Run
0xB014	End point Counter 0	500 Clocks
0xB018	Counter Clear 0	0 = No Clear
0xB058	CAMERA TRIG Selector	13 = pulse generator 0

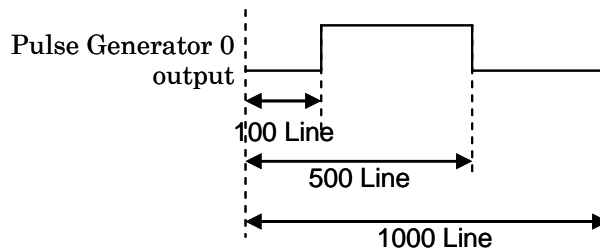
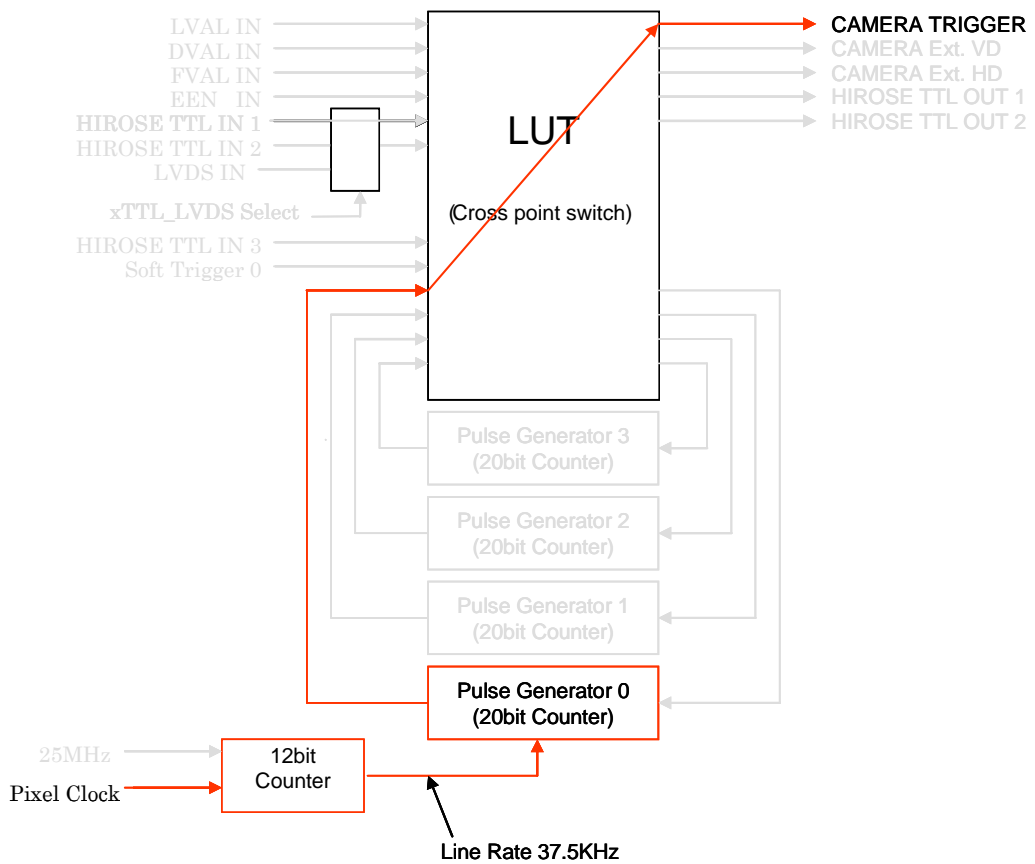

Pulse Generator 0 timing

6.4.3 Multi EEN Control with PWC

Camera EEN converts to 3 pulses and feed camera in PWC mode

Address	Register	Value
0xA040	Trigger Mode	2 = PWC(Pulse width control)
0xB000	Clock Choice	1 = Pixel Clock
0xB004	Counter Dividing Value	963 = 1/964dev(Line Rate)
0xB008	Length Counter 0	1000 Clocks
0xB00C	Start point Counter 0	100 Clocks
0xB010	Repeat Count 0	3 Cycles
0xB014	End point Counter 0	500 Clocks
0xB018	Counter Clear 0	1 = Level Low
0xB058	CAMERA TRIG Selector	4 = Hirose TTL IN 1
0xB06C	Pulse Generator 0 Selector	3 = CAMERA EEN IN

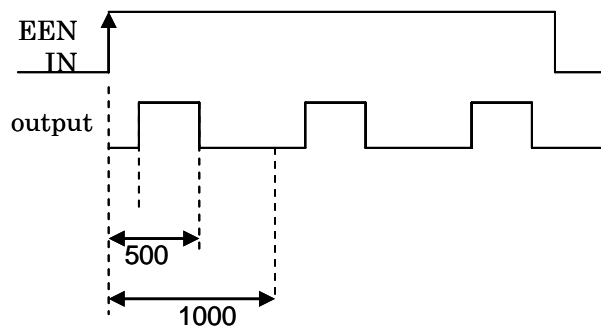
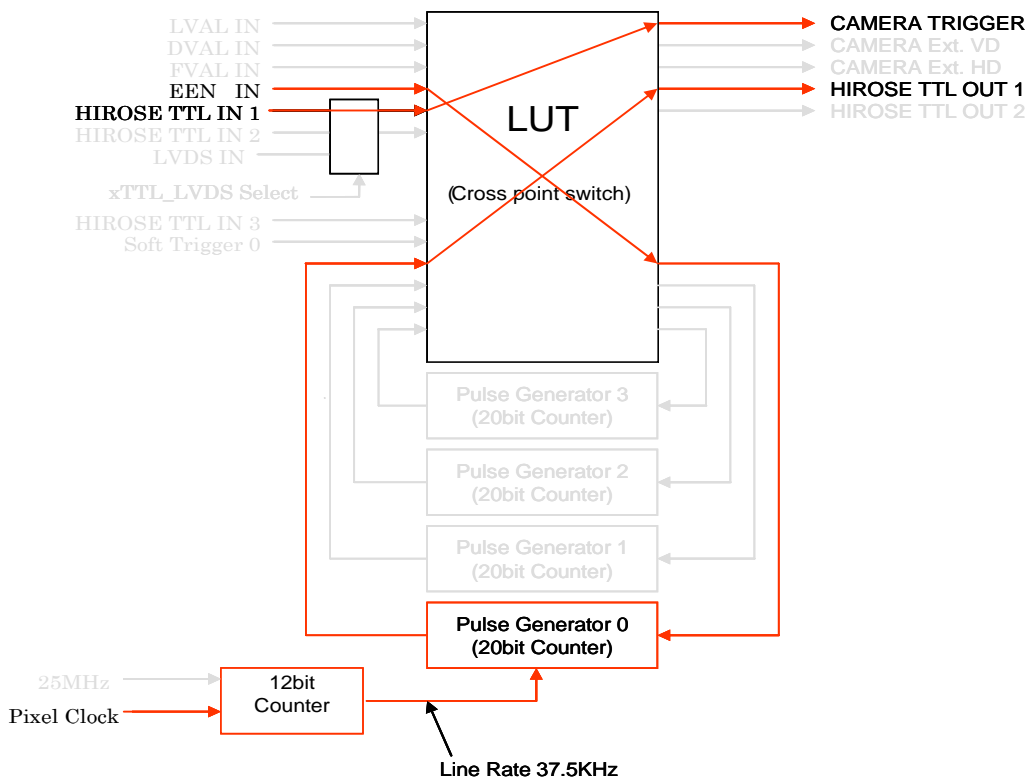

Pulse Generator 0 timing

7. GigE Vision Streaming Protocol (GVSP)

7.1. Digital Video Output (Bit Allocation)

Although the CV-M9GE is a digital camera, the image is generated by an analog component, the CCD sensor. There are three CCD sensors in this camera. One for each R, G and B channel. The table and diagram below show the relationship between the analog CCD output level and the digital output.

CCD out	Analog Signal *	Digital Out(30bit)	Digital Out(24bit)
Black	Setup 3.6%, 25mV	32LSB	8LSB
200mV	700mV	890LSB	222LSB
230mV	800mV	1023LSB	255LSB

The standard setting for 10-bit video level is 890 LSB. For 8-bit, the standard setting is 222 LSB. 200 mV CCD output level, 100% video output.

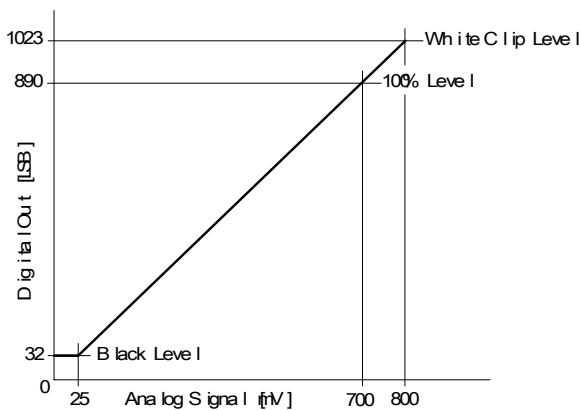

Fig.8 Digital Output

7.2. Bit Allocation (Pixel Format / Pixel Type)

In the GigE Vision Interface, GVSP (GigE Vision Streaming Protocol) is used for an application layer protocol relying on the UDP transport layer protocol. It allows an application to receive image data, image information and other information from a device.

In CV-M9GE, the following pixel types supported by GVSP are available.

With regard to the details of GVSP, please refer to the GigE Vision Specification available from AIA.

7.2.1. GVSP_PIX_BGR10V1_PACKED (32bit)

1 Byte								2 Byte								3 Byte								4 Byte							
R	R	G	G	B	B	X	X	B	B	B	B	B	B	B	B	G	G	G	G	G	G	G	G	R	R	R	R	R	R	R	R
0	1	0	1	0	1	X	X	2	3	4	5	6	7	8	9	2	3	4	5	6	7	8	9	2	3	4	5	6	7	8	9

Little Endian Bit Alignment

7.2.2. GVSP_PIX_BGR10V2_PACKED (32bit)

1 Byte								2 Byte								3 Byte								4 Byte							
R	R	R	R	R	R	R	R	R	R	G	G	G	G	G	G	G	G	G	B	B	B	B	B	B	B	B	B	B	X	X	
0	1	2	3	4	5	6	7	8	9	0	1	2	3	4	5	6	7	8	9	0	1	2	3	4	5	6	7	8	9	X	X

Little Endian Bit Alignment

7.2.3. GVSP_PIX_RGB8_PACKED (24bit)

1 Byte 目								2 Byte 目								3 Byte 目													
R	R	R	R	R	R	R	R	G	G	G	G	G	G	G	G	B	B	B	B	B	B	B	B	B	B	B	B	B	B
0	1	2	3	4	5	6	7	0	1	2	3	4	5	6	7	0	1	2	3	4	5	6	7						

Little Endian Bit Alignment

Address	Internal Name	Access	Size	Value
0xA410	Pixel Format type	R/W	4	0x0220001C:BGR10V1 Packed 0x0220001D:BGR10V2 Packed 0x02180014:RGB8 Packed

8. Functions and Operations

8.1. GigE Vision Standard Interface

The CV-M9 GE is designed in accordance with the GigE Vision standard. It transmits digital images over CAT5e or Cat6 Ethernet cables. All camera functions are also controlled via the GigE Vision interface.

The camera can operate in a continuous mode, providing an endless stream of images. For capturing individual images, related to a specific event, the camera can also be triggered. For precise triggering, it is recommended to use a hardware trigger applied to the Hirose 12-pin connector. It is also possible to initiate a software trigger through the GigE Vision interface. However, when using software trigger, certain latency inherent to the GigE interface must be anticipated. This latency, that manifests itself as jitter, greatly depends on the general conditions and traffic on the GigE connection. The frame rate described in this manual is for the ideal case and may deteriorate depending on conditions.

8.2. Recommended Network Configurations

Although the CV-M9GE conforms to Gigabit Ethernet (IEEE 802.3) not all combinations of network interface cards (NICs) and Switches/Routers are suitable for use with the GigE Vision compliant camera.

JAI will endeavor to continuously verify these combinations, in order to give users the widest choice of GigE components for their system design.

8.2.1 Verified Network Interface Cards (NICs)

At the time of publishing this document these combinations have been verified:

NIC manufacturer	Model	PCI Bus	PCI-X Bus	PCI-Express Bus
Intel	PRO/1000MT (PWLA8490MT)	√ (33MHz)	√(100MHz)	–
Intel	PRO/1000GT (PWLA8391GT)	√ (33MHz)	√ (33MHz)	–
Intel	PRO/1000PT (EXPI9300PT)	–	–	√ (x1)

Minimum PC requirements are as follows in order to fulfill the above conditions:

Intel P4 2.8G(HT) or better, alternatively AMD Athlon 64 x2, CPU

At least 1 GB memory

More than 200 GB free disk space

Windows XP, SP2(32bit)

Optimized filter driver included in the JAI SDK Light

To ensure the integrity of packets transmitted from the camera is recommended to follow these simple guidelines:

1. Whenever possible use a peer-to-peer network.
2. When connecting several cameras going through a network switch, make sure it is capable of handling jumbo packets and that it has sufficient memory capacity.
3. Configure inter-packet delay to avoid congestion in network switches.
4. Disable screen saver and power save functions on computers.
5. Use high performance computers with multi-CPU, hyper-thread and 64-bit CPU, etc.
6. Only use Gigabit Ethernet equipment and components together with the camera.
7. Use at least Cat5e or preferably Cat6 Ethernet cables.
8. Whenever possible, limit the camera output to 24-bit.

Video bit rate for CV-M9GE is:

24 bit pixel format (GVSP_PIX_RGB8)	566 M bit/s (1024(H) x 768(V) x 30(Frame) x 24(bit))
30 bit pixel format (GVSP_PIX_RGBVD)	755 M bit/s (1024(H) x 768(V) x 30(Frame) x 30(bit))

However, as the UPD Packet Header is added, the real bit rate will increase by 10%.

8.3. Basic functions

A 16-bit processor controls all functions in the CV-M9GE camera. The CCD sensor output is normalized in preamplifiers. The signals are then digitized to 12 bits. Digital gain control and look-up tables perform signal processing in 12-bits before it is truncated to a 10 or 8 bit for BGR GigE Vision standard packet format.

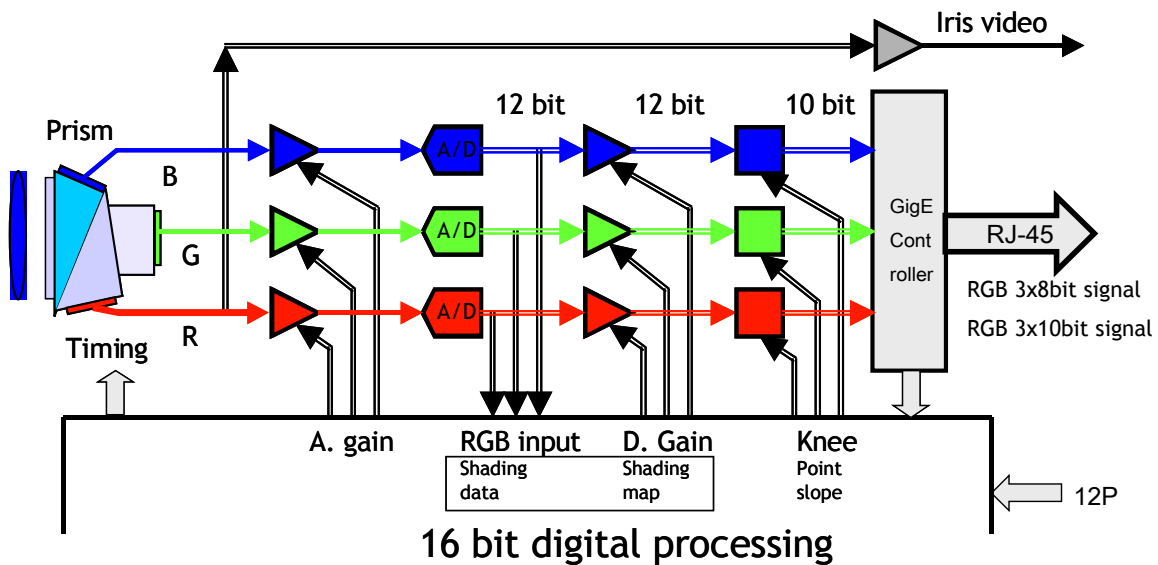

Fig. 9. Principle diagram for signal processing

8.3.1. White Balance (by gain setting)

By adjusting the R and B gain settings, it is possible to have correct color balance in the video output. A white scene will be shown as a white image. This white balance can be done in different ways:

- (1) Manual white balance (user adjusts gain settings)
- (2) One-push automatic white balance
- (3) Continuous (tracking) automatic white balance
- (4) Pre-defined color temperature settings: 3200K (factory default), 4600K and 5600K.

The register 0xA0C0 is used to select the function.

Manual white balance

By adjusting the Red (Register 0xA0C8); Blue (Register 0xA0CC) and Master Gain (Register 0xA0C4) gains settings, it is possible to achieve a proper white balance output from the camera for a wide range of color temperatures. The recommended method is to point the camera at a white target, and adjust gain settings until image on the screen matches the target.

One-push white balance. (Set register 0xA0D0 to 0x00)

If this register is set, an automatic white balance is performed once. To use this function the camera must be operating in the continuous mode.

The result of this function (0 = complete; 1 = too dark; 2 = too bright; 3 = timeout; 4 = busy; 5 = out of range; 6 = trigger mode not set to continuous) can be read out of register 0xA0D8.

Please see the register map for complete details of the register settings and responses.

Set Auto White Balance area.

With this function it is possible to select which part of the image the automatic white balance function uses to calculate the gain settings.

The register 0xA0D4 is used to set this function.

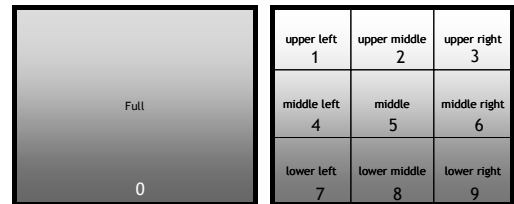

Fig. 10. Auto white balance areas.

8.3.2. White balance (by individual R, G and B channel shutter settings)

In order to achieve proper white balance without compromising signal-to-noise ratio, it is possible to adjust the exposure (shutter) time of each R, G and B channel individually. Please see chapter 8.3.6. Electronic Shutter for details on how to set this function.

8.3.3. Automatic Dynamic shading correction

The CV-M9GE camera has a digital shading correction circuit, which can compensate for prism chromatic shading, for lens shading and for CCD shading. It makes the choice of lenses wider. The camera with a given lens and a given f-number is looking on a homogeneous white scene. A horizontal profile of the shading in 128 points is made for the 3 colors.

A vertical profile of the shading in 96 points is made for the 3 colors. The average level of each divisions for R,G and B respectively is compared with the level of the image centre and the level difference compensates the video data. The resulting image is then compensated for shading caused by the lens, prism and CCD.

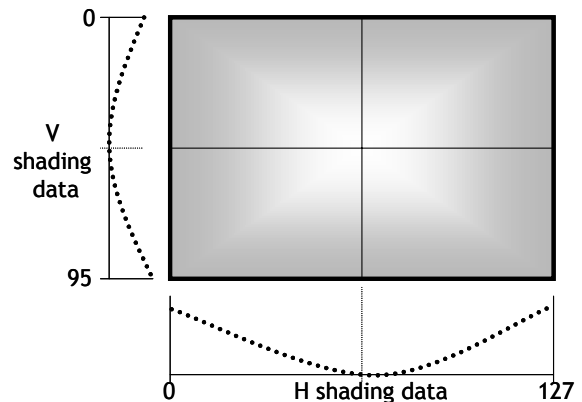

Fig. 11. Dynamic shading correction.

The factory setting is done with a Fujinon 15mm F2.2 lens, with the iris is set to F5.6.

Note: Lens requirements.

Although the shading correction widens the choice of lenses for this camera, it is recommended to use lenses designed for 1/3" 3 CCD cameras to obtain the best image quality. As chromatic shading depends of the focal length and the iris setting of the lens, avoid using wide-angle lenses, and working with the lens iris setting fully open.

8.3.4. Knee function

The video signal is digitized to 3x12-bit and the most significant 3x8 or 3x10-bit are presented at the output. By using a look-up table function it is possible to compress the video signal to change the dynamic range. It can be done individually for R, G and B with the Knee Function.

The Knee Function is given by 2 sets of parameters. Knee point and slope. These 2 sets of data determine the relationship between output and input data. This conversion is done in hardware (FPGA) using the knee data.

The normal transfer function is with a slope 1:1. From a given point and up, the slope can be changed. This point is the knee point parameter, and its range is from 0 to 1023 referring to the video output. The factory setting is 890.

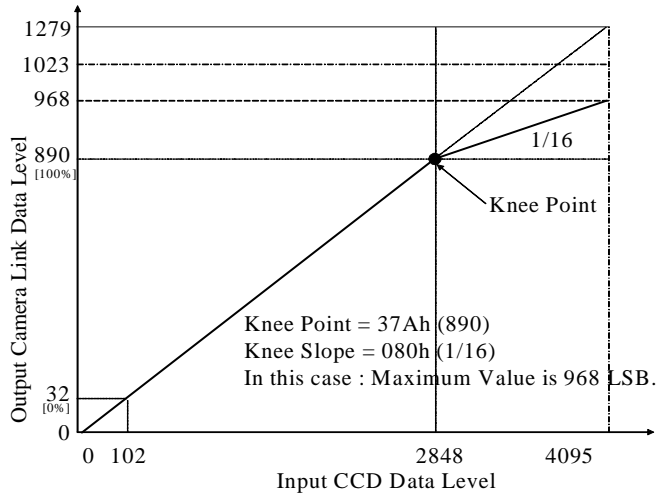

Fig. 12. Knee function.

The new slope can be set from 1:0 to 1:2.

A slope 1:0 is a clipper function, which will limit the output signal. A slope 1:2 will function as a 2 times contrast expanding function.

The slope parameter range is from 0 to 4095.

0 is slope 1:0.

2048 is slope 1:1.

4095 is slope 1:2.

The factory setting is 800, giving a slope of $800/2048 = 1:0.39$. All of the above is based on 3x10-bit output.

8.3.5. ROI (Region of Interest)

The CV-M9GE allows two ROIs to be set. The ROI must not be overlapped.

The following is a matrix chart for ROI and Trigger modes. Please note that "ROI 2" and "ROI 1 + ROI 2" is not a standard GenICam function.

For setting ROIs, use registers 0xA41C through 0xA43C.

Trigger Mode	ROI 1	ROI 2	ROI 1 + ROI 2
EPS Trigger	Yes	Yes	Yes
PWC Trigger	Yes	Yes	Yes
Sequential EPS Trigger	Yes (Note1)	No	No
Sequential PWC Trigger	Yes (Note1)	No	No
EPS Trigger Delayed Readout	Yes	No	No
PWC Trigger Delayed Readout	Yes	No	No
Sequential EPS Trigger Delayed Readout	Yes (Note1)	No	No
Sequential PWC Trigger Delayed Readout	Yes (Note1)	No	No

Note 1: ROI 1 setting for "Sequential" must use registers 0xA808 through 0xA8A4 on register map.

8.3.6. Electronic Shutter

The CV-M9GE has two conventional shutter functions, Preset Shutter and Programmable Exposure, as well as the GenICam standard “Exposure Time Abs” function:

Preset shutter (Register 0xA004)

12 pre-set (fixed) shutter speeds, OFF (1/30); 1/60; 1/100; 1/120; 1/250; 1/500; 1/1,000; 1/2,000; 1/4,000; 1/10,000; 1/16,000 and 1/50,000, can be selected by this function.

Programmable Exposure (Register 0xA008 - common setting)

The shutter speed can be set by 1L increments in the range of 0.5L to 791L. 791L corresponds to shutter OFF (1/30). L=42.07µs (line period) for full frame and partial scan.

Programmable Exposure (Registers 0xA00C [Red], 0xA010 [Green] and 0xA010 [Blue])

Individual shutter settings for R, G or B channels are available for Continuous and Edge Pre-Select (EPS) trigger modes only.

The actual exposure time should add 0.5L in addition to setting lines number due to 0.5L overhead in the range of 0L to 790 L.

Shutter speed (Time) for Trigger Mode

		Minimum exposure time	Max. exposure time
Continuous and EPS	Normal Partial	20µs	1 Frame(note 1)
	V-Binning	30µs	
PWC	Normal Partial	$42.07\mu s \times 2L + 20\mu s(0.5L) = 66.7\mu s$ ($\approx 1/10,000s$)	60 Frame (Note 1)
	V-Binning	$50.96\mu s \times 2L + 30.\mu s(0.5L) = 131.7\mu s$ ($\approx 1/8,000s$)	

Note1): The maximum shutter time depends on total lines of each read out system.

- Exposure time for Normal Readout = PE(Line) x 1H(42.07us) + 20us (PE=0 ~ 791)
- Exposure time for 1/2 Partial Readout = PE(Line) x 1H(42.07us) + 20us (PE=0 ~ 491)
- Exposure time for 1/4 Partial Readout = PE(Line) x 1H(42.07us) + 20us (PE=0 ~ 347)
- Exposure time for 1/8 Partial Readout = PE(Line) x 1H(42.07us) + 20us (PE=0 ~ 275)
- Exposure time for V-Binning Readout = PE(Line) x 1H(50.96us) + 30us (PE=0 ~ 395)

Exposure Time Abs (Register 0xA054)

This is a function specified in the GenICam standard.

The shutter speed can be entered as an absolute exposure time in microseconds (µs) in register address 0xA054. The entered absolute time (Time Abs) is then converted to programmable exposure (PE) value inside the camera.

In this mode, the minimum exposure time is 20 µs and then after, the shutter value is changed by 42 µs increment.

The relation with PE value is:

- PE = INT (Exposure time / 42) for Normal Readout, 1/2 Partial to 1/8 Partial mode
- PE = INT (Exposure time / 51) for V-Binning Readout mode

Note: “INT” means integer (truncated).

Shutter and Mode matrix

	Preset		Programmable	
	RGB common	RGB individual	RGB common	RGB individual
Continuous	Yes	-	Yes	Yes
EPS	Yes	-	Yes	Yes
PWC	-	-	-	-

8.3.7. Color bar for test

The CV-M9GE camera has a build in color bar generator. When it is activated, the output image will be as shown below. The RGB values are shown for both 8 and 10 bit output.

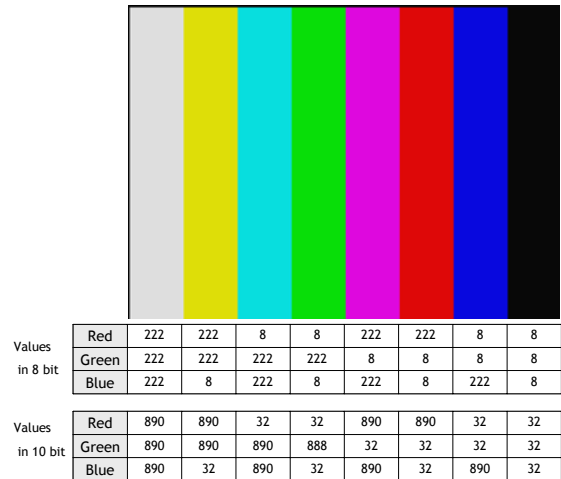

Fig. 13. Color bar RGB values

8.3.8. Analogue output for Auto Iris Lens

This signal is available only for the continuous mode. The signal is fed from CCD output and therefore the setting of camera gain does not affect this output. The video signal does not include composite sync and the output level is 0.7 V p-p with 75 ohms output impedance.

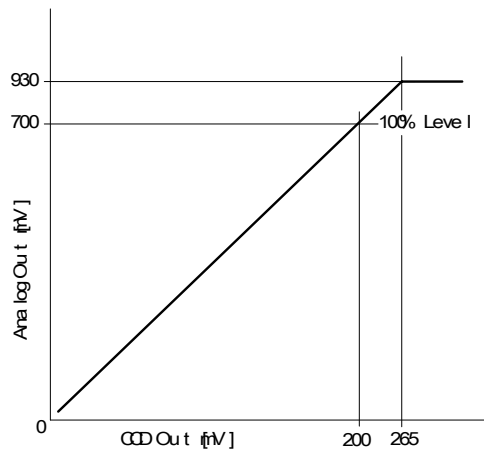
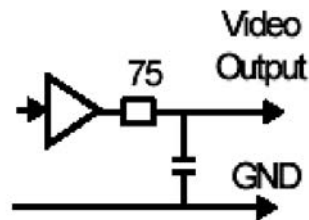

Fig.14 Lens Iris Analogue output

8.4. Sensor Layout and timing

8.4.1. CCD Sensor Layout

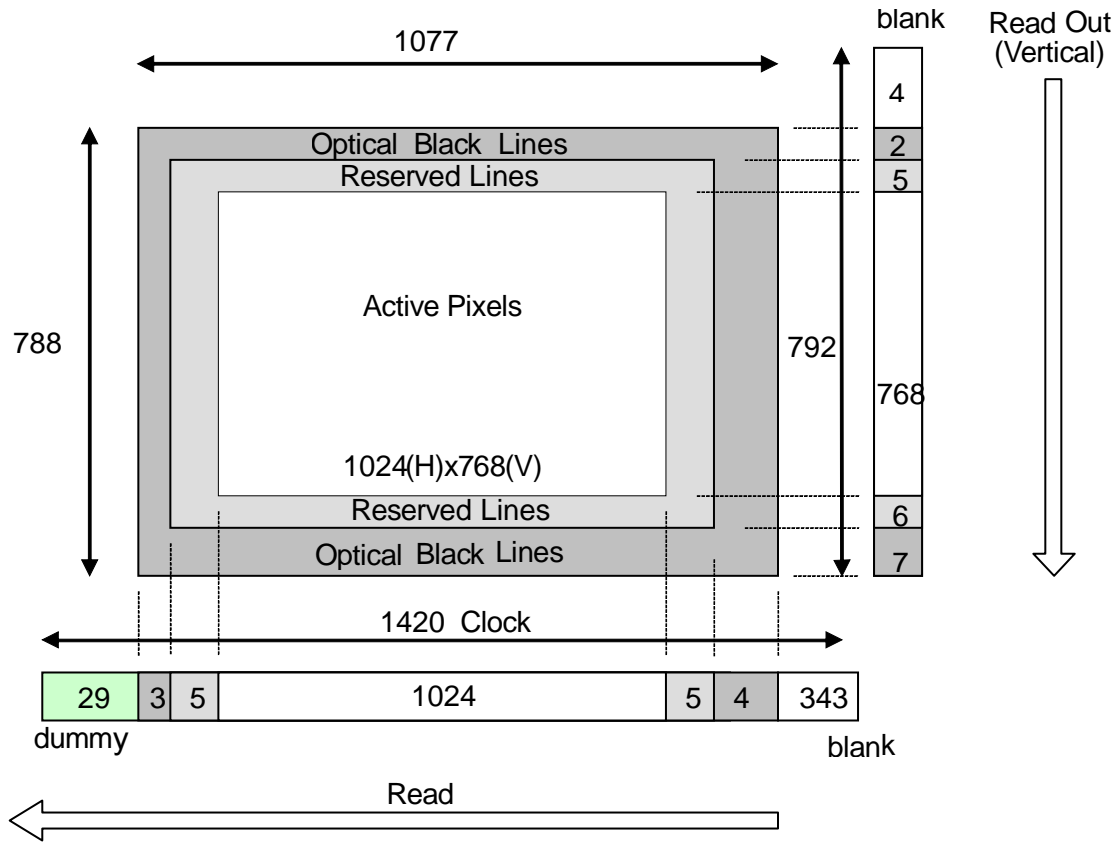

Fig. 15. CCD sensor layout

Important Note: In GigE Vision, only Active Pixel Area is output through the GigE interface. Dummy, optical black and reserved areas are not output.

Table for scanning.

The below table shows the start line, the stop line and the number of active lines in the vertically centered area of the CCD sensor. The front and back lines are the lines used for the fast dump readout in partial scanning mode.

Scanning	Start line #	End line #	Active lines	Front lines	Back lines	Blank lines	Remarks
Full	1	768	768	12	8	4	
Partial 1/2	192	576	384	54	50	4	
Partial 1/4	288	480	192	78	74	4	
Partial 1/8	336	432	96	90	86	4	
V. Binning	1/2	767/768	384	5	4	3	

Note:

The following pages show the timing chart for Full, Partial and Vertical binning readout modes. These timing charts describe internal camera timing and the output through Gigabit Ethernet. Only the active lines, i.e. 768 lines for full scanning, are output.

8.4.2. Horizontal timing

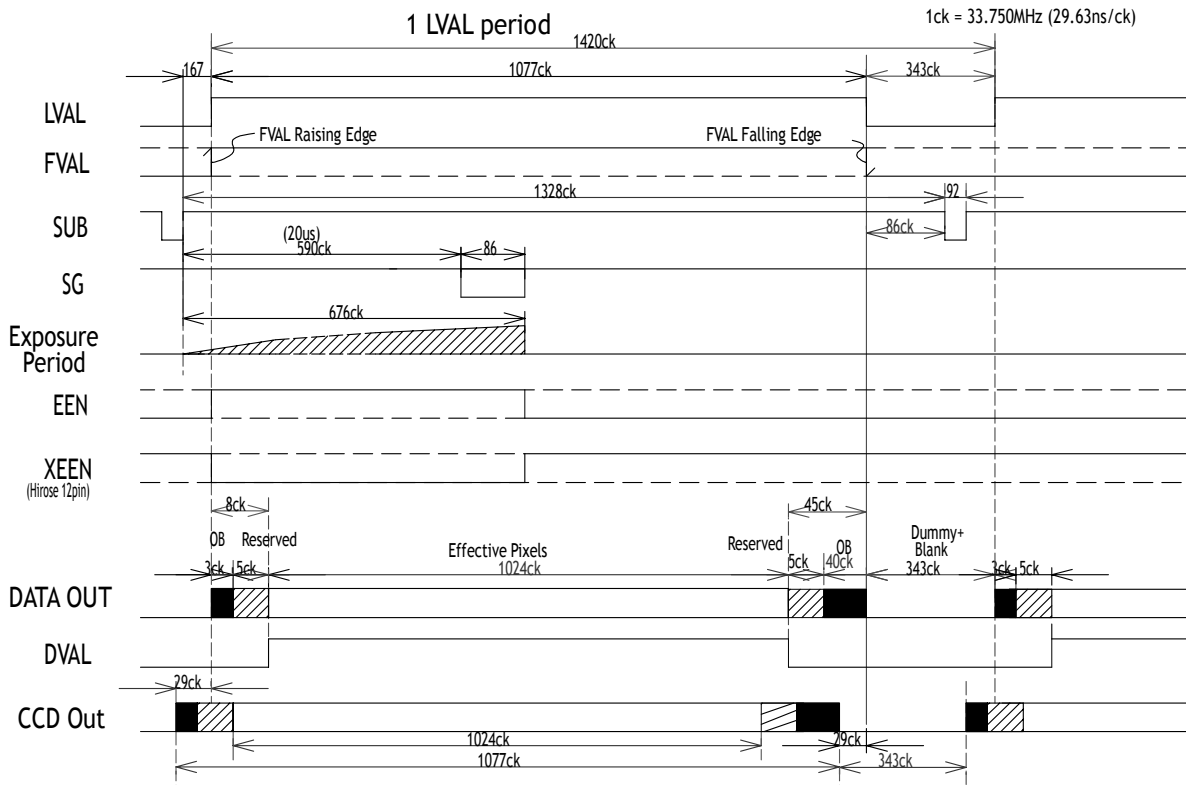

Fig. 16. Horizontal timing

8.4.3. Vertical timing

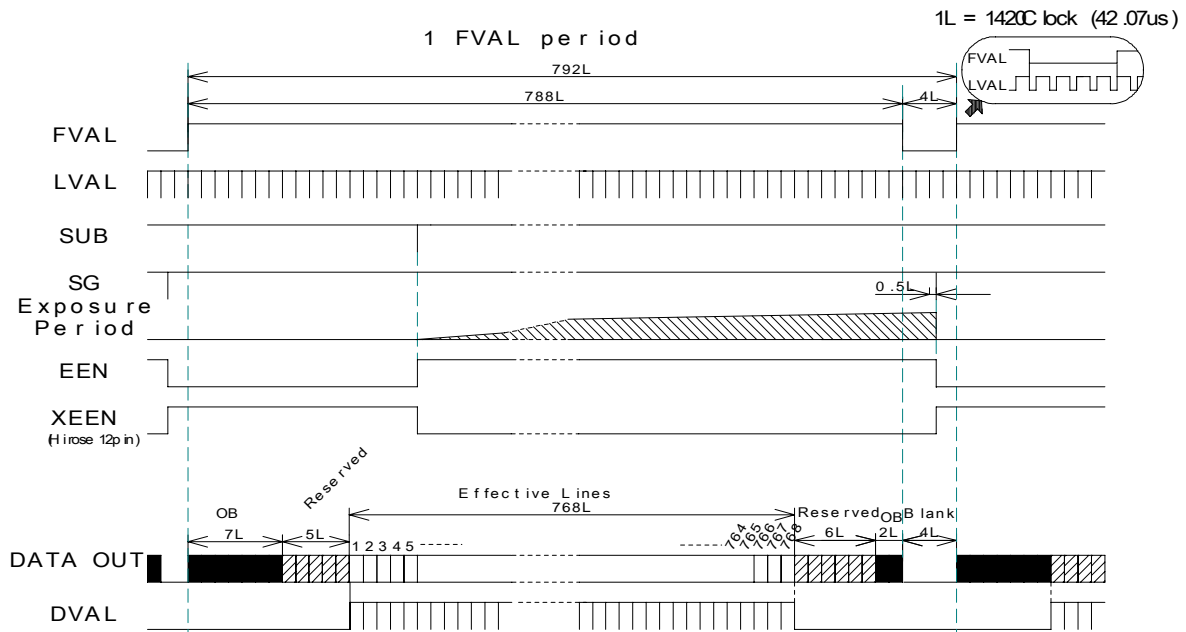

Fig. 17. Vertical timing for full scan

8.4.4. Partial Scanning

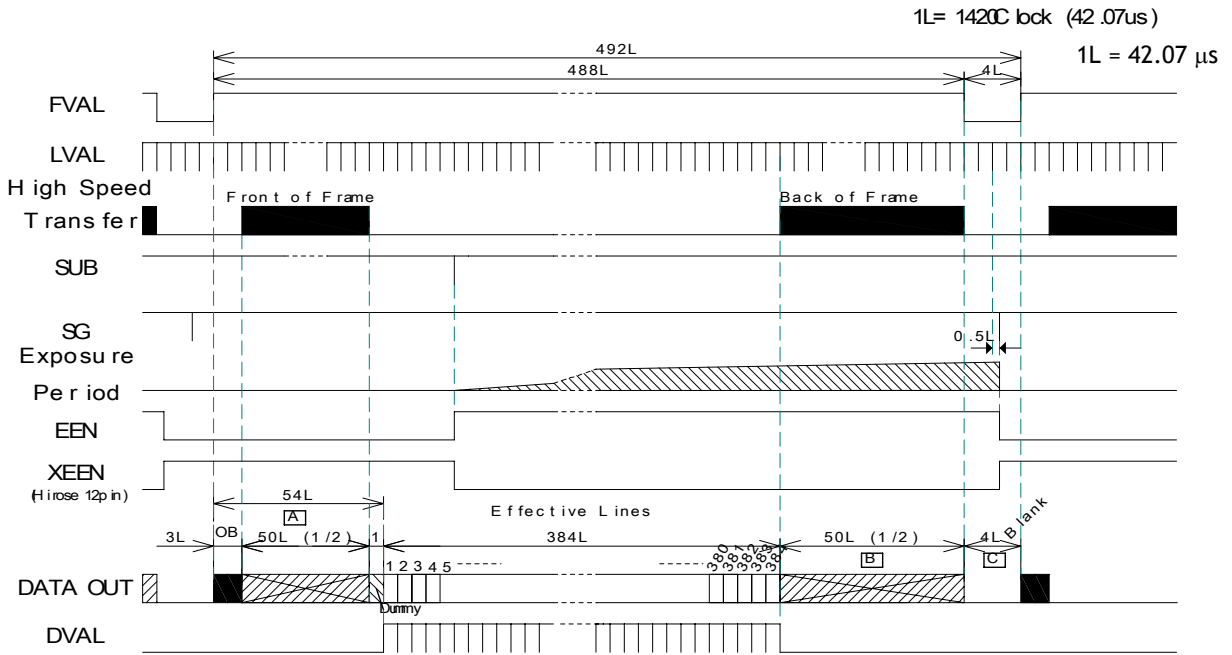

Fig. 18 Vertical timing for 1/2 partial scan

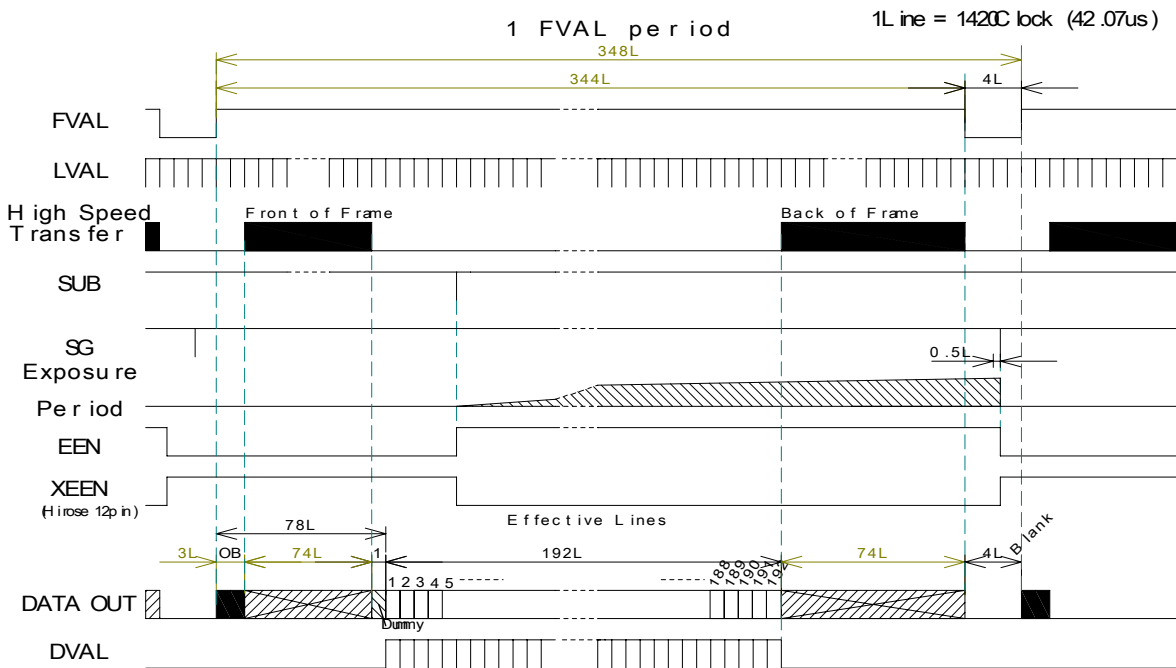

Fig. 19 Vertical timing for 1/4 partial scan

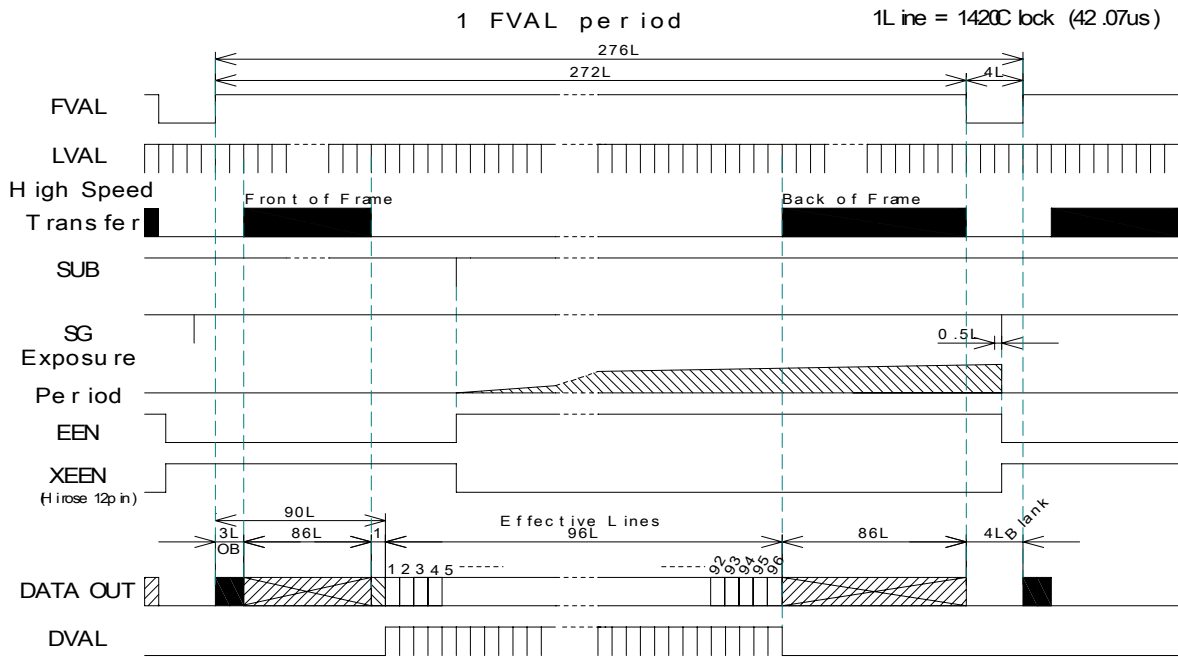

Fig. 20 Vertical timing for 1/8 partial scan

8.4.5. Vertical binning

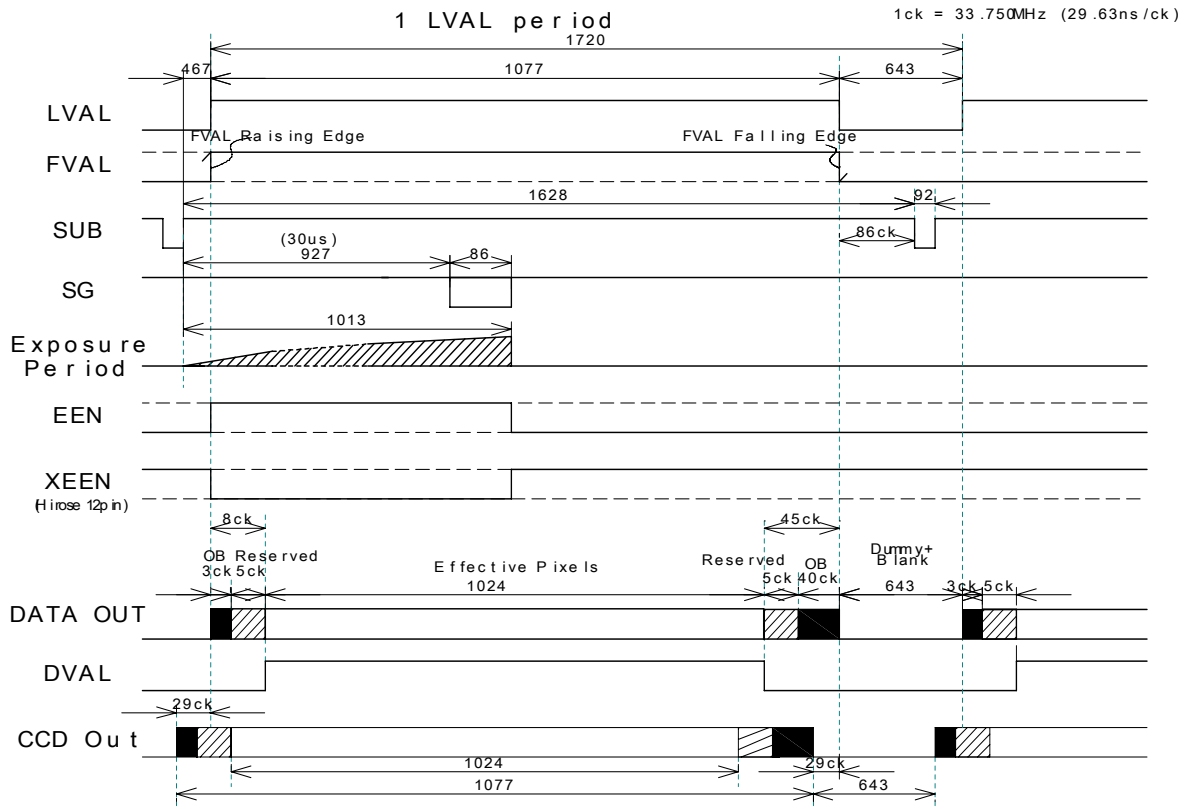

Fig.21 Horizontal timing for V binning.

CV-M9 GE

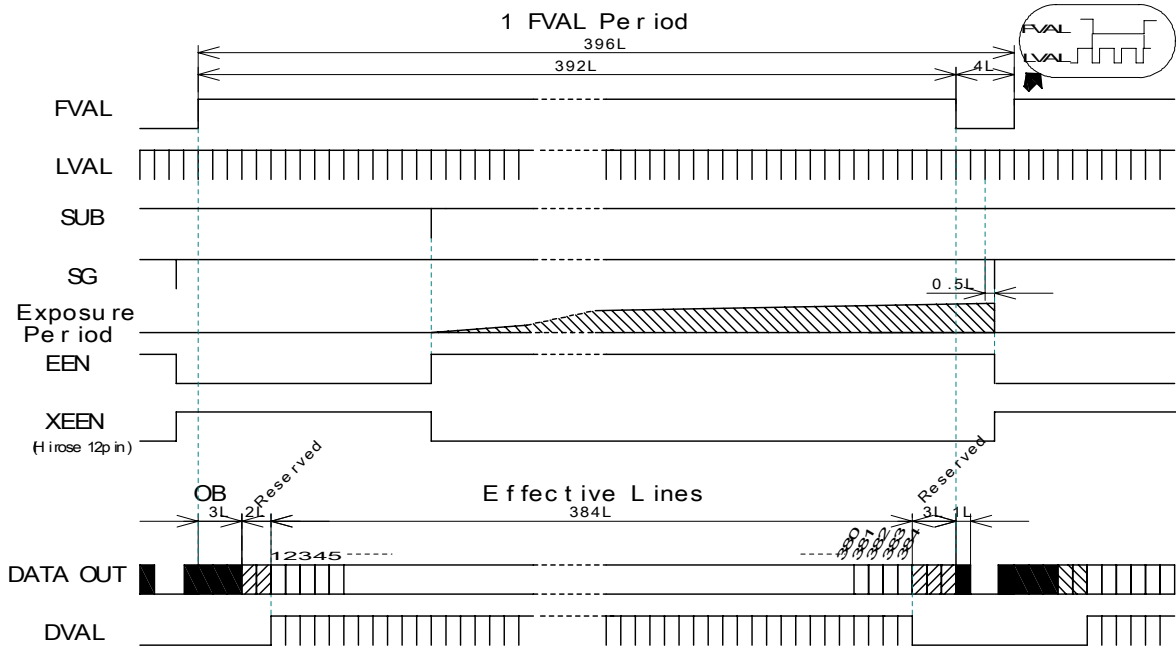

Fig. 22. Vertical timing for V binning.

8.5. Operation Modes

This camera can operate in 5 primary modes.

- | | |
|--|----------------------------------|
| 1. Continuous Mode | Pre-selected exposure. |
| 2. Edge Pre-select Mode (EPS) | Pre-selected exposure. |
| 3. Pulse Width Control Mode (PWC) | Pulse width controlled exposure. |
| 4. <i>Sequential Trigger</i> | Pre-selected exposure (EPS) |
| 5. <i>Delayed Readout Trigger</i> | Pre-selected exposure (EPS/PWC) |

The triggered accumulation in EPS, PWC, Sequential Trigger and Delayed Readout Trigger can be LVAL synchronous or LVAL a-synchronous.

In LVAL synchronous accumulation, a new exposure can be started while the previous frame is read out. The new exposure should not be finished before the frame is read out. FVAL (Trigger Duration) shall be low for >2 LVAL. The maximum frame rate in trigger modes can then be close to the frame rate in continuous mode.

The minimum trigger interval should be longer than $(1 \text{ FVAL} + 1 \text{ LVAL})$ in the case of Smear Less OFF and Same RGB exposure time.

In LVAL a-synchronous accumulation, a new trigger must not be applied before the previous frame is read out. (FVAL is low).

The minimum trigger interval should be longer than $(\text{exposure time} + 1 \text{ FVAL} + 1 \text{ LVAL})$.

Refer to chapter 8.5.1. and 8.5.2. for accumulation details.

8.5.1. LVAL synchronous accumulation

In LVAL accumulation mode, the accumulation will start synchronously with LVAL. The trigger pulse should be longer than 2 LVAL ($\text{LVAL} = 42.07 \mu\text{s}$). The accumulation will start at the first LVAL after the trigger leading edge. The exposure start delay will be up to 1 line. ($42.07 \mu\text{sec.}$). In EPS mode the exposure stops 0.5 L after the selected shutter time, (in number of LVAL). In PWC mode the exposure stops 0.5 L after the first LVAL after the trigger trailing edge. It results in up to 1 LVAL jitter.

In trigger modes with LVAL synchronous accumulation, a new exposure can be started while the previous frame is read out. The new exposure should not finish before the frame is read out. FVAL (Trigger Duration) shall be low for >2 LVAL. The maximum frame rate in trigger modes can then be close to the frame rate in continuous mode.

Minimum trigger interval $\geq (1 \text{ FVAL} + 1 \text{ LVAL})$. (EPS mode)

note: Smear-less OFF / Common exposure time for RGB

Edge Pre-Select Mode : Full Frame

1L = 1420Clock (42.07us)

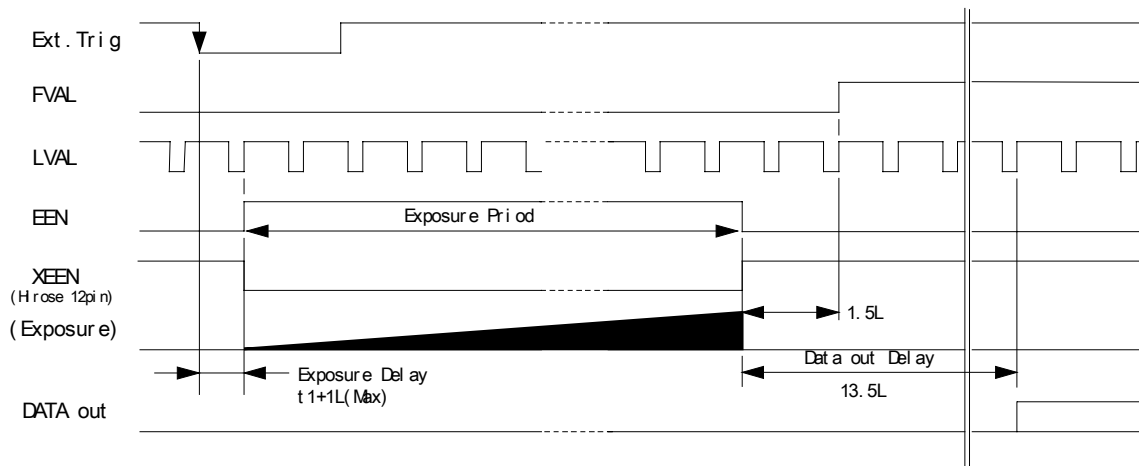

Fig. 23. LVAL synchronous accumulation in EPS mode

Pulse Width Control Mode : Full Frame

Pulse Width Control mode の例 (Full Frame)

1L = 1420Clock (42.07us)

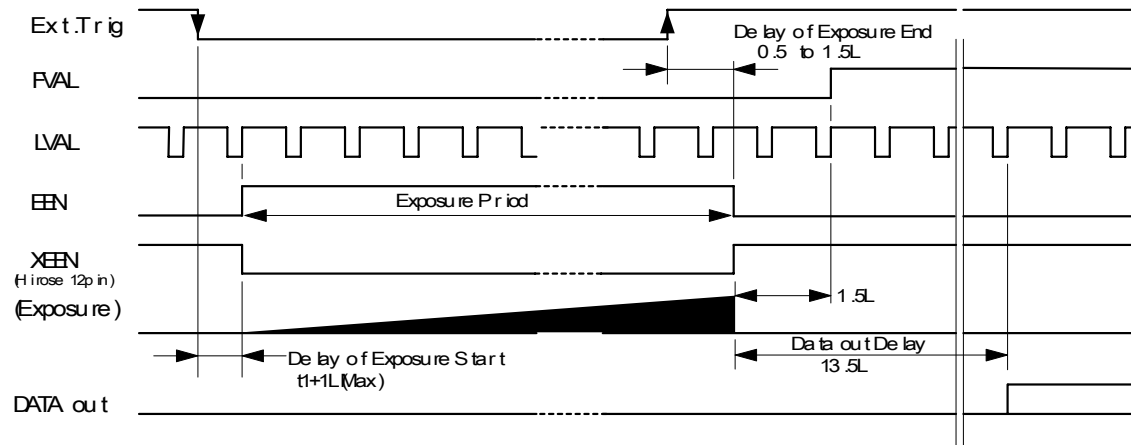

Fig. 24. LVAL synchronous accumulation in PWC mode

8.5.2. LVAL a-synchronous accumulation

In LVAL a-synchronous mode, the accumulation will start immediately after the trigger leading edge. The exposure start delay is 9.7 μsec. (In V-binning mode, this delay will be 39.7 μsec) In EPS mode the exposure stops 0.5 L after the selected shutter time, (in number of LVAL). In PWC mode the exposure stops 29.7μsec after the trigger trailing edge. A new trigger must not be applied before the previous frame is read out. (FVAL is low).

Minimum trigger interval ≥ (exposure time + 1 FVAL + 1 LVAL). (EPS mode)

Edge Pre-select Mode : Full Frame

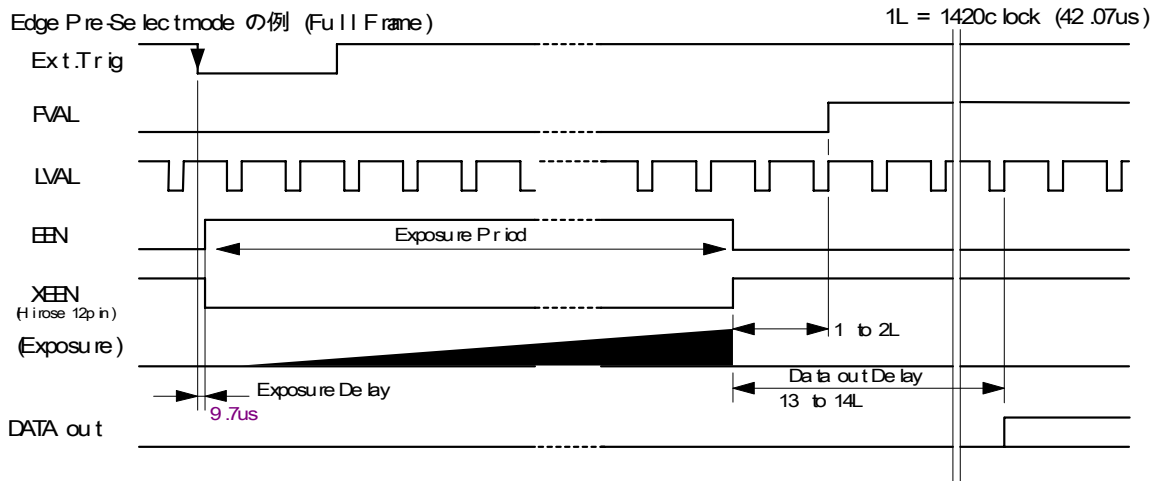

Fig. 25. LVAL a-synchronous accumulation in EPS mode

Pulse Width Control Mode : Full Frame

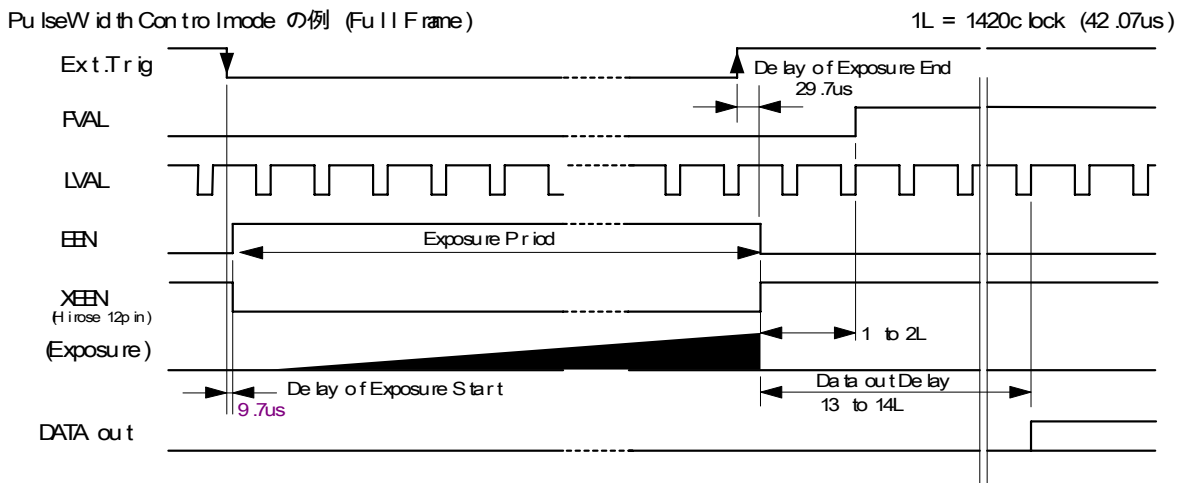

Fig. 26. LVAL a-synchronous accumulation in PWC mode

Note: In V-Binning mode, the delay of exposure end is 39.7μs (1L=1720 clk)

8.5.3. Continuous operation

For applications not requiring asynchronous external trigger, but where a continuous stream of images is required, this mode should be used.

In this mode it possible to use an auto-iris lens (video drive). The CV-M9GE provides an auto-iris lens video signal at pin 4 of the 12-pin Hirose connector.

For timing details, refer to fig. 16. through fig. 22.

To use this mode:

Set function:	Trigger mode	Continuous
	Scanning	Full, Partial scanning
	Vertical binning	On/Off
	Shutter mode	Preset, Programmable
	Shutter speed or Programmable exposure	

8.5.4. Edge Pre-select Trigger Mode

An external trigger pulse initiates the capture, and the exposure time (accumulation time) is the fixed shutter speed set by registers. The accumulation can be LVAL synchronous or LVAL a-synchronous.

The resulting video signal will start to be read out after the selected shutter time.

For timing details, refer to fig. 16. through fig. 22. and fig. 27.

To use this mode:

Set function:	Trigger mode	EPS
	Scanning	Full, Partial
	Vertical binning	ON / OFF
	Shutter mode	Preset, Programmable
	Shutter speed	
	Programmable exposure	
	Accumulation	LVAL Sync / LVAL a-sync
	Other functions and settings	
Input:	Ext. trigger.	Gigabit Ethernet or 12-pin Hirose

Important notes on using this mode

- Trigger pulse >2 LVAL to <1 FVAL)
- Minimum trigger interval in synchronous accumulation mode
 - In case R,G and B exposure is common :

$$\geq (1 \text{ FVAL}(792\text{L}) + 1 \text{ LVAL})$$
 - In case R,G and B exposure is individual :

$$\geq (\text{Max. Exp. time} - \text{Min. Exp. time}) + 1 \text{ FVAL} (792\text{L}) + 1 \text{ LVAL}$$
- Minimum trigger interval in a-synchronous accumulation mode

$$\geq (\text{exposure time} + 1 \text{ FVAL}(792\text{L}) + 1 \text{ LVAL}).$$
- Minimum trigger interval in Smear-less ON:

$$\geq (\text{Smear-less time} (198\text{L}) + \text{Max. Exp. time} + 1\text{FVAL}(792\text{L}) + 1 \text{ LVAL}$$
- Minimum trigger interval with Sequential Mode together
 - In case the same R,G and B shutter value for all sequences, and SYNC mode

$$\geq 1 \text{ FVAL} (792\text{L}) + 1\text{L}$$
 - In case the same shutter for each sequence, (SYNC/a-SYNC)

$$\geq \text{Maximum Exposure} + 1 \text{ FVAL} (792\text{L}) + 1\text{L}$$
 - In case the different shutter for R,G and B, (SYNC/a-SYNC)

$$\geq (\text{Max. Exp. time} - \text{Min. Exp. time}) + 1 \text{ FVAL} (792\text{L}) + 4 \text{ LVA}$$

- In EPS trigger mode, R, G and B exposure can be set individually. Provided the gain in each channel is set to the same value, this function allows white balance to be achieved with the same noise level (S/N ratio) for all channels. Please note that extreme differences in exposure time, e.g. R ch set to 1/30s and G ch is to 1/50,000s can result in deteriorated image quality.

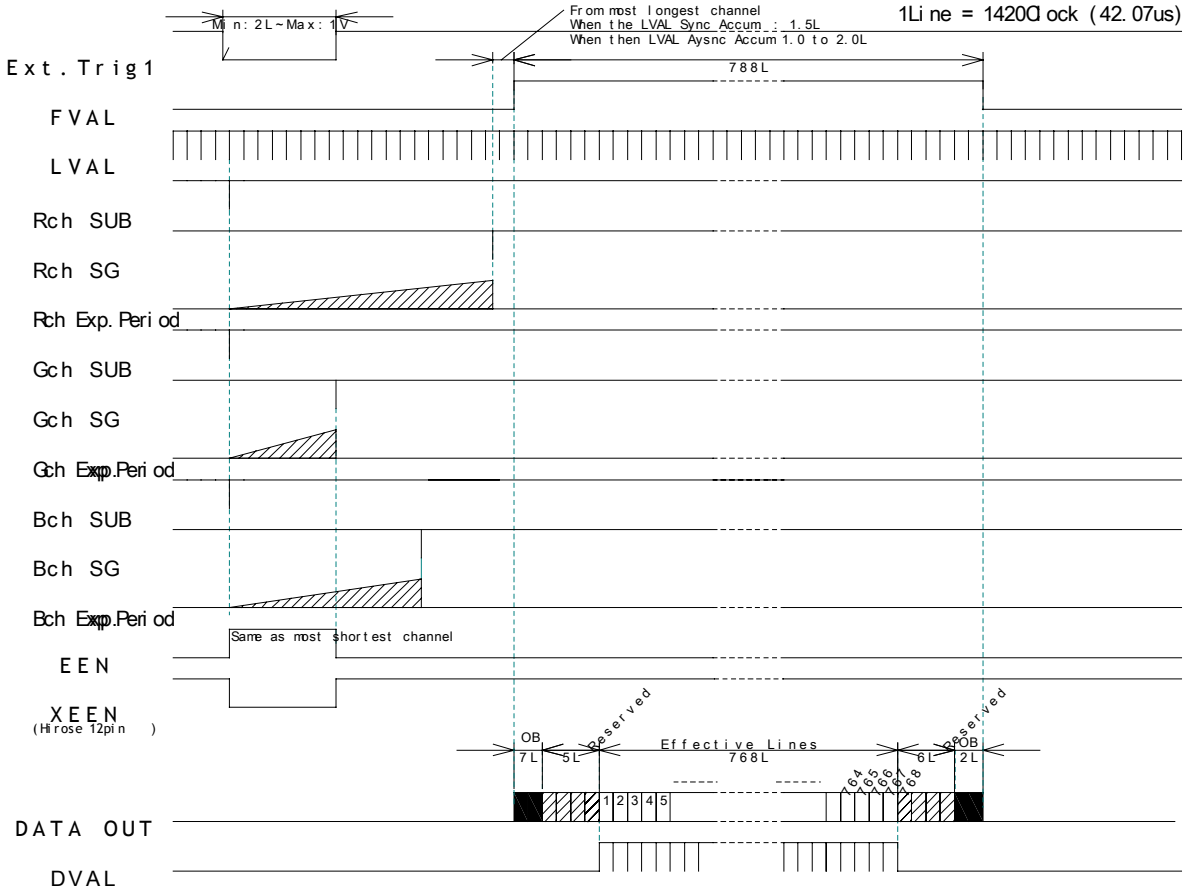

Fig. 27. Edge pre-select. LVAL synchronized.

8.5.5. Pulse Width Control Trigger Mode

In this mode the accumulation time is equal the trigger pulse width. Here it is possible to have long time exposure. The maximum recommended time is < 2 second.
 The accumulation can be LVAL synchronous or LVAL a-synchronous.
 The resulting video signal will start to be read out after the trigger rising edge.
 For timing details, refer to fig. 16. through fig. 22. and fig. 28.

To use this mode:

Set function:	Trigger mode	PWC
	Scanning	Full ,Partial
	Vertical binning	ON / OFF
	Accumulation	LVAL sync / LVAL a-sync
	Other functions and settings	
Input:	Ext. trigger.	Gigabit Ethernet or 12-pin Hirose

Important notes on using this mode

- Trigger pulse width >2 LVAL to <1 second.
- Minimum trigger interval in synchronous accumulation mode
 In case the exposure time is less than 1 FVAL (792L):
 $\geq (1 \text{ FVAL}(792L) + 1 \text{ LVAL})$
 In case the exposure time is more than or equal to 1 FVAL (792L):
 $\geq (\text{Exp. time} + 2 \text{ LVAL})$
- Minimum trigger interval in a-synchronous accumulation mode
 $\geq (\text{exposure time} + 1 \text{ FVAL} + 2 \text{ LVAL}).$
- Minimum trigger interval in Smear-less ON:
 $\geq (\text{Smear-less time} (198L) + 1\text{FVAL}(792L) + 2 \text{ LVAL})$
- In PWC mode and Smear-less ON, the actual exposure time is (Trigger duration - Smear-less time (198L)). If the trigger duration is less than 198L, the exposure time of the output video is 1/50,000s.

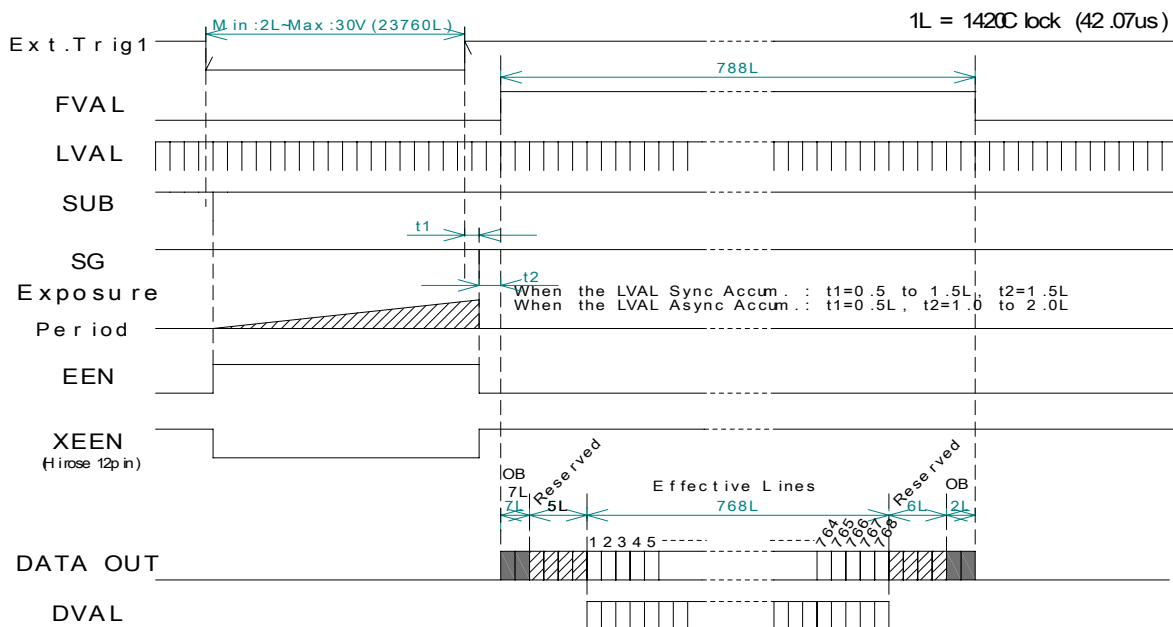
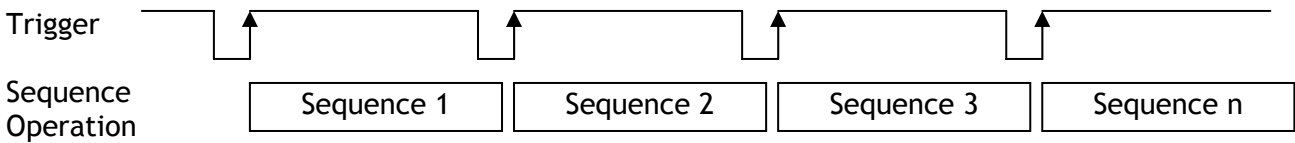

Fig. 28. Pulse width control. LVAL synchronized.

8.5.6. Sequential Trigger Mode (EPS)

Shutter, Gain and ROI values can be preset for up to 10 sequences. Along with every trigger input, the image data with the preset sequence is output as described below.



Signals added to trigger can be selected by 0xB058 Camera Trigger Selector on register map via the GPIO. The camera will functions on the raising edge of the trigger and Negative or Positive should be determined accordingly.

For the sequence, the following default settings are installed.

ID	ROI				Shutter			Gain		
	Width	Height	Offset X	Offset Y	R Channel	G Channel	B Channel	R Channel	G Channel	B Channel
1	1024	768	0	0	791	791	791	0	0	0
2	1024	768	0	0	791	791	791	0	0	0
3	1024	768	0	0	791	791	791	0	0	0
4	1024	768	0	0	791	791	791	0	0	0
5	1024	768	0	0	791	791	791	0	0	0
6	1024	768	0	0	791	791	791	0	0	0
7	1024	768	0	0	791	791	791	0	0	0
8	1024	768	0	0	791	791	791	0	0	0
9	1024	768	0	0	791	791	791	0	0	0
10	1024	768	0	0	791	791	791	0	0	0

The following registers are necessary to operate the sequence.

- 0xA800 Number of Repetitions
- 0xA804 Ending Position
- 0xA3F0 Sequence Reset
- 0xB058 Trigger source input TTL1, 2 and 3 on 12-pin Hirose connector as well as soft trigger
- 0xA040 Trigger mode selection (EPS)

Example of settings

Setting : Repeat 5 times from ID 1 through ID 8

- 0xA44C “Video Sending Flag” is set to 0 (Acquisition End)
- 0xA040 Set to Continuous mode (0) for stop
- 0xA800 Set to 0x05 (repetitions)
- 0xA804 Set to 0x08 (end point)
- 0xB058 e.g. set to 0x06 (TTL 3 at pin 10 of the 12-pin Hirose connector at trigger source)
- 0xA040 Set to 0x09 for Sequential EPS
- 0xA44C “Video Sending Flag” is set to 1 (Acquisition Start)
- 0xA3F0 Set this register to 0x01 for start
- 0xA040 Set to Continuous Mode (0) for stop

To create an endless loop (infinite repetitions) set 0xA800 to 0x00. Further details are available in the Register Map section of this manual.

Important Note for using this mode

1. When this mode is used, it is necessary to set "Video Sending Flag" to OFF at first and then set the trigger mode to "Continuous" (Register 0xA040 to 0).
The shutter mode must then be set at Individual Shutter (0xA000 set to 2) regardless of the trigger modes.
Now select the sequence trigger mode (0xA040 to 8), and set "Video Sending Flag" (0xA44C) to ON (Acquisition start).
If the above sequence is not followed, the sequence function will not work properly.
2. When the mode is changed, the trigger must be OFF. Otherwise, the sequence may be not in order. After changing the mode, it is necessary to send Sequence Reset Command (Set 0xA3F0 to 1).
3. In this mode, if the "Video Sending Flag" is ON (Acquisition Start), it is not possible to save the data in User 0 to 3.
4. During operation, do not change the shutter mode (0xA000).

8.5.7. Delayed Readout Mode (EPS, PWC)

This mode can be used to delay the transmission of a captured image. When several cameras are triggered simultaneously and connected to the same GigE interface, it allows the cameras to be read out in sequence, preventing congestion.

The image data is not transmitted directly by the trigger and it is stored in the memory located at Ethernet Interface. By the falling edge of the soft trigger 1, the image data is output.

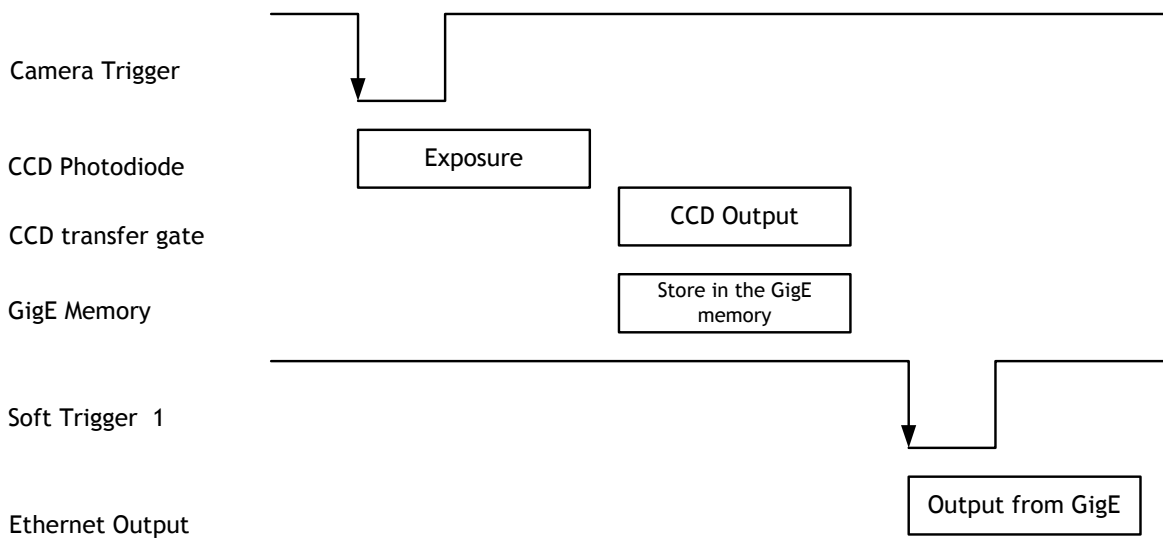

Example of settings

- 0xA040 EPS Delayed Readout (17) or PWC Delayed Readout (18)
- 0xA418 Soft Trigger 1 (30 bit)

Further details are available in the Register Map section of this manual.

Important Note for using this mode

1. When this mode is used, it is necessary to set "Video Sending Flag" to OFF at first and then set the trigger mode to "Continuous". Then, set it to "Delayed Trigger Mode". After this the "Video Sending Flag" can be set to ON (Acquisition Start).
2. After trigger mode is changed, the camera must receive more than 1 trigger pulse before the Soft Trigger is sent. Otherwise the image will not be sent.

8.5.8. Smear-less Mode

This function will reduce the unwanted smear signal from a highlighted scene when a short exposure time is used. It works in EPS and PWC trigger modes, but a dummy readout is performed before the active accumulation is started. It will remove the smear above the highlighted parts in the image, but there is still smear left below highlighted areas. The trigger leading edge will start the dummy readout. It takes 198 LVAL (8.33ms) before the exposure starts. The exposure stops and the resulting video signal is read out. This mode will operate with full and partial scanning and with all binning modes.

PWC Trigger Mode, without Smear-less mode

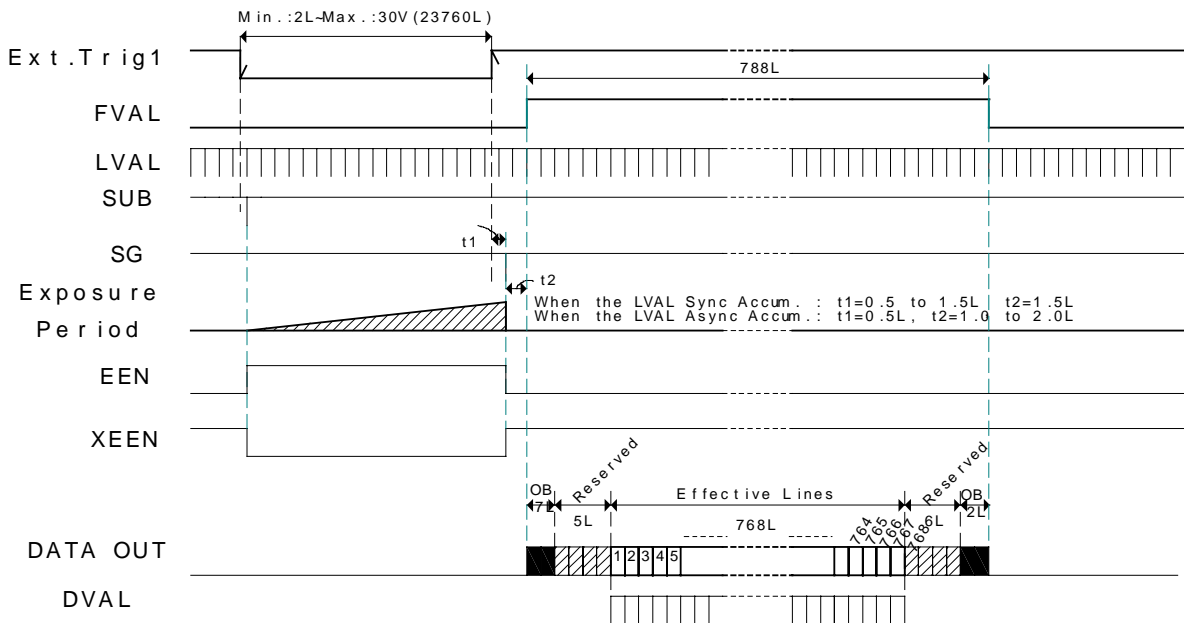

Fig. 29 PWC Mode without Smear Less Mode

PWC Trigger Mode, with Smear-less Mode

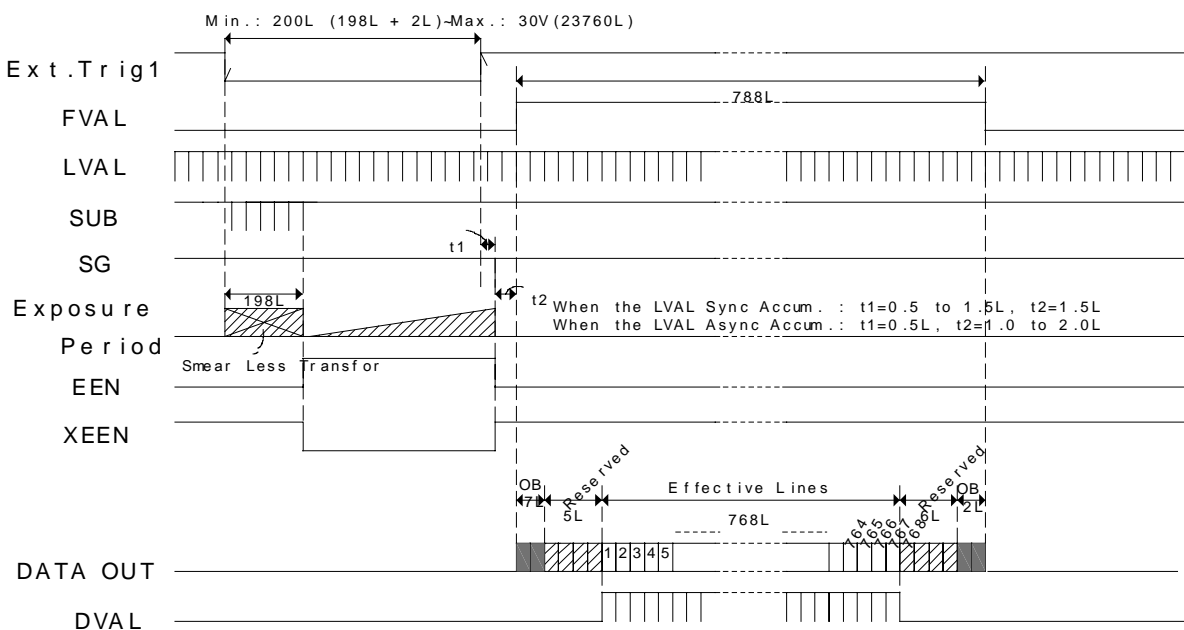

Fig. 30 PWC Mode with Smear Less Mode

8.6. Operation Mode and Functions matrix

ID (Value)	Mode	Shutter Preset / Program.	Binning	Partial Scanning	Smear-less	LVAL Sync/Async	Auto Iris output
0x00	Continuous	Yes	Yes	Yes	No	Not applicable	Yes Note 2.
0x01	Edge Pre-select (EPS)	Yes	Yes	Yes	Yes	Yes	No
0x02	Pulse Width Control (PWC)	Not applicable	Yes	Yes	Yes	Yes	No
0x09	Sequential Edge Pre-select	Yes	Yes	Yes	Yes	Yes	No
0x11	EPS Delayed Readout	Yes	Yes	Yes	Yes	Yes	No
0x12	PWC Delayed Readout	Not applicable	Yes	Yes	Yes	Yes	No

Write ID in register address 0xA040 in order to set trigger mode.

Note 1: Before switching between trigger modes ID 0x09 through 0x12, first set to “ID- 00x0, Continuous mode” and then set “Video Sending Flag - Register 0xA44C” to OFF.

Note 2: In partial scan mode Auto Iris output is available, but Auto Exposure is not available.

Note 3: When using trigger modes in combination with Smear-less readout, only LVAL-synchronous accumulation is active.

Note 4: In PWC trigger mode, do not use LVAL a-synchronous accumulation if the trigger pulse has a pulse width exceeding 3 frames.

9. Register Map

The below table provides detailed information for the hardware registers used for controlling the camera and obtaining information on the status of the camera.

The content of this register map is also found in the XML file, as stipulated by the GenICam standard.

Generic Registers:

Address	Function	Read / Write	Size	Value / Range of value	Description	Default value
0x0000	Version	R	4	(Major, Minor) vector	Version of the GigE Standard to which the device is compliant.	
0x0004	Device mode	R	4		Information about device mode of operation.	
0x0008	Device MAC address (high)	R	4		Upper 4 bytes of the MAC address	
0x000c	Device MAC address (low)	R	4		Lower 4 bytes of the MAC address	
0x0010	IP	R	4	Bit 0: persistent Bit 1: DHCP Bit 2: LLA	Bits can be OR-ed. All other bits are reserved and set to 0. DHCP and LLA bits must be on.	
0x0014	IP address setup	R/W	4	Bit 0: persistent Bit 1: DHCP Bit 2: LLA	Bits can be OR-ed. LLA is always activated and is read only.	
0x0024	Current IP address	R	4			
0x0034	Current subnet mask	R	4			
0x0044	Current default gateway	R	4			
0x0048	Manufacturer's name	R	32		e.g. JAI	
0x0068	Model name	R	32		e.g. CV-A9GE	
0x0088	Device version	R	32			
0x00A8	Manufacturer specific info	R	80		Provides extended manufacturer information about the device.	
0x00D8	Serial number	R	16		Camera serial number	
0x00E8	Camera ID	R/W	16		User assignable string	
0x0200	First choice of URL for XML device description file	R	512		File extension .XML indicates uncompressed text file. File extension .ZIP indicates compressed using ZIP.	
0x0400	Second choice of URL for XML	R	512			
0x0600	Number of network interfaces	R	4		Indicates the number of physical network interfaces on this device.	
0x064C	persistent IP address	R/W	4		Valid if Persistent IP is enabled	
0x065C	persistent subnet mask	R/W	4		Valid if Persistent IP is enabled	
0x066C	persistent gateway	R/W	4		Valid if Persistent IP is enabled	
0x0900	number of messaging channels	R	4	This camera has 1	number of available message channel	

CV-M9 GE

0x0904	number of stream channels	R	4	This camera only has 1	number of available stream channel	
0x0934	GVCP capability	R	4	Bit 31:multiple read Bit 30:WRITEMEM Bit 29:CKETRESEND Bit 28:EVENT Bit 27:EVENTDATA	This is a capability register indicating which one of the non-mandatory GVCP commands are supported by this device.	
0x0938	Heartbeat timeout	R/W	4	The min. value is 500 ms	In milliseconds. Internally, the heartbeat is rounded according to the clock used for heartbeat.	3000 msec
0x093C	Timestamp tick frequency (High)	R	4	Timestamp tick frequency is 0 if timestamp is not supported.	64-bit value indicating the number of timestamp clock ticks in 1 second. This register holds the most significant bytes.	
0x0940	Timestamp tick frequency (Low)	R	4		This register holds the least significant bytes.	
0x0944	Timestamp control	W	4	Bit 0: Reset Bit 1:latch current timestamp	Used to latch the current timestamp value. No need to clear to 0.	
0x0948	Timestamp (High)	R	4		Latched value of the timestamp (most significant bytes)	
0x094C	Timestamp (Low)	R	4		Latched value of the timestamp (least significant bytes)	
0x0a00	CCP	R	4		control channel privilege register	
0x0b00	MCP	R/W	4		message channel port register	0
0x0b10	MCDA	R/W	4	Set by application	message channel destination address register	
0x0b14	MCTT	R/W	4		message channel transfer timeout: ms	300
0x0b18	MCRC	R/W	4		message channel retry count	2
0x0d00	SCP0	RW	4	Not specified	primary stream port register	
0x0d04	SCPS0	R/W	4	Set by application	primary stream channel packet size register packet size includes IP, UDP&GVSP Header	1440
0x0d08	SCPDO	R/W	4	Max. 2 ms	primary stream channel packet delay register	64
0x0d18	SCDAO	R/W	4	Set by application	primary stream channel destination address register	

CV-M9 GE

Standard camera functions registers:

Address	Function	Read / Write	Size	Value / Range of value	Description	Default value
0xA000	Shutter mode	R/W	4	0= Preset shutter (RGB common) 1= Programmable exposure (RGB common) 2= Programmable exposure (RGB individual) 4= Exposure Time Abs	Sets exposure time for image capture. Mode 0 and 1 are for common RGB setting. Mode 2 is for individual RGB setting.	0
0xA004	Preset shutter	R/W	4	0=Off; 1=1/100; 2=1/120; 3=1/250; 4=1/500; 5=1/1000; 6=1/2000; 7=1/4000; 8=1/8000; 9=1/15000; 10=1/25000; 11=1/75000; 12=1/100000; 13=1/150000; 14=1/300000	Fixed values for setting exposure	0
0xA008	Programmable exposure, PE	R/W	4	0 to 791	Common RGB setting Flexible setting of exposure time ranging from 1/50000s (0.5L) to 1/30s (791L) using the LVAL period (L) as increment. 1L is 42.07 μ s.	791
0xA00C	Programmable Exposure for Red	R/W	4	0 to 791	Use with Shutter mode (0xA000) set to 2	791
0xA010	Programmable Exposure for Green	R/W	4	0 to 791	Use with Shutter mode (0xA000) set to 2	791
0xA014	Programmable Exposure for Blue	R/W	4	0 to 791	Use with Shutter mode (0xA000) set to 2	791
0xA040	Trigger Mode	R/W	4	0=Continuous 1=Edge pre-select 2=Pulse width control 4=Reset Continuous 8=Sequential Trigger 16=Delayed Readout Trigger	It is possible to combine modes by adding register settings. E.g. set register to 17 (16 + 1) results in Delayed Readout Edge pre-selected Trigger	0
0xA04C	Smear-less	R/W	4	0=Off, 1=On	Smear reduction	0
0xA050	LVAL sync/ a-sync Accumulation	R/W	4	0=Sync, 1=Async	"Sync" means that accumulation starts at the next LVAL. "Async" means that accumulation starts immediately (no delay)	0
0xA054	Exposure Time Abs	R/W	4	21 μ s to 33.3 ms	Actual exposure time in microseconds, μ s. The camera will round value off to match LVAL increments.	33300 μ s
0xA080	Partial Scan	R/W	4	0=Full Frame 1=1/2 Partial 2=1/4 Partial 3=1/8 Partial	The partial scan area is vertically centred on the sensor.	0

CV-M9 GE

0xA084	Vertical Binning	R/ W	4	0= OFF 1= ON	2 line binning	0
0xA08C	Color test pattern	R/ W	4	0=Off, 1=On		0
0xA0C0	White Balance	R/ W	4	0=Manual/One push 1=Continuous AWB 2=3200K 3=4600K 4=5600K		0
0xA0C4	Master Gain Level	R/ W	4	-132 to +429 0		0
0xA0C8	Gain level for Red	R/ W	4	-231 to +231 0		0
0xA0CC	Gain level for Blue	R/ W	4	-231 to +231 0		0
0xA0D0	One push Auto White Balance	W	4	0=One push Auto White Balance		
0xA0D4	Set Auto White Balance sensing Area	R/ W	4	0=Full Area 1=Upper left 2=Upper middle 3=Upper right 4=Middle left 5=Middle 6=Middle right 7=Lower left 8=Lower middle 9=Lower right		5
0xA0D8	Request the Result of One Push Auto White Balance	R	4	0=Complete. 1=Too Bright 2=Too dark 3=Timeout Error 4=Busy 5=Color temp. out of range 6= Camera not set to Continuous mode	Note: Response 5 means that either Red or Blue gain has reached the maximum without being able to perform white balance	
0xA0DC	Auto Black Mode	R/ W	4	0=On, 1=Off		0
0xA0E0	User Black Level for Green	R/ W	4	0 to 64		32
0xA0E4	User Black Level for Red	R/ W	4	0 to 64		32
0xA0E8	User Black Level for Blue	R/ W	4	0 to 64		32
0xA100	Knee On/Off	R/ W	4	0=On, 1=Off		0
0xA104	Knee Slope for Red	R/ W	4	1 to 4095		800
0xA108	Knee Slope for Green	R/ W	4	1 to 4095		800
0xA10C	Knee Slope for Blue	R/ W	4	1 to 4095		800
0xA110	Knee Point for Red	R/ W	4	0 to 1023		890
0xA114	Knee Point for Green	R/ W	4	0 to 1023		890
0xA118	Knee Point for Blue	R/ W	4	0 to 1023		890
0xA11C	Shading Correction	R/ W	4	0=On, 1=Off 0		0
0xA120	Recalibrate shading	W	4	R= Run shading correction		

CV-M9 GE

0xA180	Load Settings	W	4	0=Factory area 1=User area1 2=User area2 3=User area3	Allow the user to recall all camera settings.	1
0xA184	Save Settings into User area	W	4	1=User area1 2=User area2 3=User area3	Allows use to save all camera settings. Last used area number becomes new default.	1

Sequence function registers, Shutter & Gain:

Address	Function	Read / Write	Size	Value / Range of value	Description	Default value
0xA2A8	Save sequence settings	W	4	1: Save On	User area only	
0xA300	Sequence Shutter R-1	R/W	4	0 to 791	Pre-program Red-1 shutter	791
0xA304	Sequence Shutter R-2	R/W	4	0 to 791	Pre-program Red-2 shutter	791
0xA308	Sequence Shutter R-3	R/W	4	0 to 791	Pre-program Red-3 shutter	791
0xA30C	Sequence Shutter R-4	R/W	4	0 to 791	Pre-program Red-4 shutter	791
0xA310	Sequence Shutter R-5	R/W	4	0 to 791	Pre-program Red-5 shutter	791
0xA314	Sequence Shutter R-6	R/W	4	0 to 791	Pre-program Red-6 shutter	791
0xA318	Sequence Shutter R-7	R/W	4	0 to 791	Pre-program Red-7 shutter	791
0xA31C	Sequence Shutter R-8	R/W	4	0 to 791	Pre-program Red-8 shutter	791
0xA320	Sequence Shutter R-9	R/W	4	0 to 791	Pre-program Red-9 shutter	791
0xA324	Seq. Shutter R-10	R/W	4	0 to 791	Pre-program Red-10 shutter	791
0xA328	Sequence Shutter G-1	R/W	4	0 to 791	Pre-program Green-1 shutter	791
0xA32C	Sequence Shutter G-2	R/W	4	0 to 791	Pre-program Green-2 shutter	791
0xA330	Sequence Shutter G-3	R/W	4	0 to 791	Pre-program Green-3 shutter	791
0xA334	Sequence Shutter G-4	R/W	4	0 to 791	Pre-program Green-4 shutter	791
0xA338	Sequence Shutter G-5	R/W	4	0 to 791	Pre-program Green-5 shutter	791
0xA33C	Sequence Shutter G-6	R/W	4	0 to 791	Pre-program Green-6 shutter	791
0xA340	Sequence Shutter G-7	R/W	4	0 to 791	Pre-program Green-7 shutter	791
0xA344	Sequence Shutter G-8	R/W	4	0 to 791	Pre-program Green-8 shutter	791
0xA348	Sequence Shutter G-9	R/W	4	0 to 791	Pre-program Green-9 shutter	791
0xA34C	Seq. Shutter G-10	R/W	4	0 to 791	Pre-program Green-10 shutter	791
0xA350	Sequence Shutter B-1	R/W	4	0 to 791	Pre-program Blue-1 shutter	791
0xA354	Sequence Shutter B-2	R/W	4	0 to 791	Pre-program Blue-2 shutter	791
0xA358	Sequence Shutter B-3	R/W	4	0 to 791	Pre-program Blue-3 shutter	791
0xA35C	Sequence Shutter B-4	R/W	4	0 to 791	Pre-program Blue-4 shutter	791

CV-M9 GE

0xA360	Sequence Shutter B-5	R/W	4	0 to 791	Pre-program Blue-5 shutter	791
0xA364	Sequence Shutter B-6	R/W	4	0 to 791	Pre-program Blue-6 shutter	791
0xA368	Sequence Shutter B-7	R/W	4	0 to 791	Pre-program Blue-7 shutter	791
0xA36C	Sequence Shutter B-8	R/W	4	0 to 791	Pre-program Blue-8 shutter	791
0xA370	Sequence Shutter B-9	R/W	4	0 to 791	Pre-program Blue-9 shutter	791
0xA374	Seq. Shutter B-10	R/W	4	0 to 791	Pre-program Blue-10 shutter	791
0xA378	Sequence Gain 1	R/W	4	-256 to 255	Pre-program 1 st Gain value	0
0xA37C	Sequence Gain 2	R/W	4	-256 to 255	Pre-program 2 nd Gain value	0
0xA380	Sequence Gain 3	R/W	4	-256 to 255	Pre-program 3 rd Gain value	0
0xA384	Sequence Gain 4	R/W	4	-256 to 255	Pre-program 4 th Gain value	0
0xA388	Sequence Gain 5	R/W	4	-256 to 255	Pre-program 5 th Gain value	0
0xA38C	Sequence Gain 6	R/W	4	-256 to 255	Pre-program 6 th Gain value	0
0xA390	Sequence Gain 7	R/W	4	-256 to 255	Pre-program 7 th Gain value	0
0xA394	Sequence Gain 8	R/W	4	-256 to 255	Pre-program 8 th Gain value	0
0xA398	Sequence Gain 9	R/W	4	-256 to 255	Pre-program 9 th Gain value	0
0xA39C	Sequence Gain 10	R/W	4	-256 to 255	Pre-program 10 th Gain value	0
0xA3F0	Sequence Reset	W	4	1	Sequence Reset	

GigE Vision streaming related registers:

Address	Function	Read / Write	Size	Value / Range of value	Description	Default value
0xA400	Horizontal Image Size	R	4		return proper value when normal, V-bin & partial	1024
0xA404	Vertical Image Size	R	4		return proper value when normal, V-bin & partial	768
0xA410	Video Pixel Format Type	R / W	4	0x0220001C: 0x0220001D: 0x02180014:	BGR10V1 Packed BGR10V2 Packed RGB8 Packed	RGB8 Packed
0xA414	Transfer Rate	R / W	4	0=STD(30fps) 1=STD/2 2=STD/4 3=STD/8		0
0xA418	Software Trigger	R / W	4	31bit 30bit	Soft Trigger 0 Soft Trigger 1	0
0xA41C	ROI Mode	R / W	4	1=ROI1_ON / ROI2_Off 2=ROI1_Off / ROI2_ON 3=ROI1_ON / ROI2_ON	One or two ROIs can be set. They may not be overlapping	1
0xA420	ROI1 Size X	R / W	4		Width	W.Max

CV-M9 GE

0xA424	ROI1 Size Y	R/W	4		Height	H.Max
0xA428	ROI1 Offset X	R/W	4		Horizontal offset	0
0xA42C	ROI1 Offset Y	R/W	4		Vertical offset	0
0xA430	ROI2 Size X	R/W	4		Width	WidthMax
0xA434	ROI2 Size Y	R/W	4		Height	Height Max
0xA438	ROI2 Offset X	R/W	4		Horizontal offset	0
0xA43C	ROI2 Offset Y	R/W	4		Vertical offset	0
0xA44C	Video Sending Flag	R/W	4	0=Off, 1=On		0
0xA500	Payload length register	R	4		Number of bytes in a frame	
0xA504	Event ON/OFF Register	R/W	4	31 30 29 28 27	GEV_EVENT_TRIGGER GEV_EVENT_START_OF_EXPOSURE GEV_EVENT_END_OF_EXPOSURE GEV_EVENT_START_OF_TRANSFER GEV_EVENT_END_OF_TRANSFER	0

Sequence function registers, ROI:

0xA800	Sequence Mode Function 1	R/W	4	Number of repetitions		0
0xA804	Sequence Mode Function 2	R/W	4	Ending position		0
0xA808	Seq. ROI size-X 1	R/W	4	ROI1 size x-1		WidthMax
0xA80C	Seq. ROI size-X 2	R/W	4	ROI1 size x-2		
0xA810	Seq. ROI size-X 3	R/W	4	ROI1 size x-3		
0xA814	Seq. ROI size-X 4	R/W	4	ROI1 size x-4		
0xA818	Seq. ROI size-X 5	R/W	4	ROI1 size x-5		
0xA81C	Seq. ROI size-X 6	R/W	4	ROI1 size x-6		
0xA820	Seq. ROI size-X 7	R/W	4	ROI1 size x-7		
0xA824	Seq. ROI size-X 8	R/W	4	ROI1 size x-8		
0xA828	Seq. ROI size-X 9	R/W	4	ROI1 size x-9		
0xA82C	Seq. ROI size-X 10	R/W	4	ROI1 size x-10		
0xA830	Seq. ROI size-Y 1	R/W	4	ROI1 size y-1		Height Max
0xA834	Seq. ROI size-Y 2	R/W	4	ROI1 size y-2		
0xA838	Seq. ROI size-Y 3	R/W	4	ROI1 size y-3		
0xA83C	Seq. ROI size-Y 4	R/W	4	ROI1 size y-4		
0xA840	Seq. ROI size-Y 5	R/W	4	ROI1 size y-5		
0xA844	Seq. ROI size-Y 6	R/W	4	ROI1 size y-6		

CV-M9 GE

0xA848	Seq. ROI size-Y 7	R/W	4	ROI1 size y-7		
0xA84C	Seq. ROI size-Y 8	R/W	4	ROI1 size y-8		
0xA850	Seq. ROI size-Y 9	R/W	4	ROI1 size y-9		
0xA854	Seq. ROI size-Y 10	R/W	4	ROI1 size y-10		
0xA858	Seq. ROI offset-X 1	R/W	4	ROI1 offset x-1		
0xA85C	Seq. ROI offset-X 2	R/W	4	ROI1 offset x-2		
0xA860	Seq. ROI offset-X 3	R/W	4	ROI1 offset x-3		
0xA864	Seq. ROI offset-X 4	R/W	4	ROI1 offset x-4		
0xA868	Seq. ROI offset-X 5	R/W	4	ROI1 offset x-5		
0xA86C	Seq. ROI offset-X 6	R/W	4	ROI1 offset x-6		0
0xA870	Seq. ROI offset-X 7	R/W	4	ROI1 offset x-7		
0xA874	Seq. ROI offset-X 8	R/W	4	ROI1 offset x-8		
0xA878	Seq. ROI offset-X 9	R/W	4	ROI1 offset x-9		
0xA87C	Seq. ROI offset-X 10	R/W	4	ROI1 offset x-10		
0xA880	Seq. ROI offset-Y 1	R/W	4	ROI1 offset y-1		
0xA884	Seq. ROI offset-Y 2	R/W	4	ROI1 offset y-2		
0xA888	Seq. ROI offset-Y 3	R/W	4	ROI1 offset y-3		
0xA88C	Seq. ROI offset-Y 4	R/W	4	ROI1 offset y-4		
0xA890	Seq. ROI offset-Y 5	R/W	4	ROI1 offset y-5		
0xA894	Seq. ROI offset-Y 6	R/W	4	ROI1 offset y-6		0
0xA898	Seq. ROI offset-Y 7	R/W	4	ROI1 offset y-7		
0xA89C	Seq. ROI offset-Y 8	R/W	4	ROI1 offset y-8		
0xA8A0	Seq. ROI offset-Y 9	R/W	4	ROI1 offset y-9		
0xA8A4	Seq. ROI offset-Y 10	R/W	4	ROI1 offset y-10		

GPIO Registers:

0xA8B0	xTTL_LVDS Select	R/W	4	0x00 0x01	TTL In 1, TTL IN active LVDS IN active	0
0xB000	Counter Clock source	R/W	4	0x00 0x01	25MHz Pixel Clock	0
0xB004	Counter Divide by Value	R/W	4	0x000 0x001 0x002 0xFFFF	Bypass Divide by 2 Divide by 3 Divide by 4096	0
0xB008	Length Counter 0	R/W	4	0x00001 to 0xFFFFF	Defines the length of the counter	1
0xB00C	Start pt. Counter 0	R/W	4	0x00001 to 0xFFFFF	Defines the starting point of the counter	0

CV-M9 GE

0xB010	Repeat, Counter 0	R/W	4	0x00: infinite 0x01: 1 time 0xFF: 255 times	Defines the number of repeats (loops)	0
0xB014	End point Counter 0	R/W	4	0x00001 to 0xFFFFF	Defines the end point of the counter	1
0xB018	Counter 0 Clear	R/W	4	0 1 2 4 8	Free Run High Level Clear Low Level Clear Rising Edge Clear Falling Edge Clear	0
0xB01C	Length Counter 1	R/W	4	0x00001 to 0xFFFFF	Counter length	1
0xB020	Start pt. Counter 1	R/W	4	0x00001 to 0xFFFFF	Start Point	0
0xB024	Repeat Counter 1	R/W	4	0x00: infinite 0x01: 1 time 0xFF: 255 times	Repeat Count	0
0xB028	End point Counter 1	R/W	4	0x00001 to 0xFFFFF	End point	1
0xB02C	Counter 1 Clear	R/W	4	0 1 2 4 8	Free Run High Level Clear Low Level Clear Rising Edge Clear Falling Edge Clear	0
0xB030	Length Counter 2	R/W	4	0x00001 to 0xFFFFF	Counter length	1
0xB034	Start pt. Counter 2	R/W	4	0x00001 to 0xFFFFF	Start Point	0
0xB038	Repeat Counter 2	R/W	4	0x00: infinite 0x01: 1 time 0xFF: 255 times	Repeat Count	0
0xB03C	End point Counter 2	R/W	4	0x00001 to 0xFFFFF	End point	1
0xB040	Counter 2 Clear	R/W	4	0 1 2 4 8	Free Run High Level Clear Low Level Clear Rising Edge Clear Falling Edge Clear	0
0xB044	Length Counter 3	R/W	4	0x00001 to 0xFFFFF	Counter length	1
0xB048	Start pt. Counter 3	R/W	4	0x00001 to 0xFFFFF	Start Point	0
0xB04C	Repeat Counter 3	R/W	4	0x00: infinite 0x01: 1 time 0xFF: 255 times	Repeat Count	0
0xB050	End point Counter 3	R/W	4	0x00001 to 0xFFFFF	End point	1
0xB054	Counter 3 Clear	R/W	4	0 1 2 4 8	Free Run High Level Clear Low Level Clear Rising Edge Clear Falling Edge Clear	0
0xB058	Selector CAMERA TRIGGER	R/W	4	GPIO Selector: 0x00:CAMERA LVAL IN 0x01:CAMERA DVAL IN 0x02:CAMERA FVAL IN 0x03:CAMERA EEN IN 0x04:HIROSE TTL IN 1 0x05:HIROSE TTL IN 2		0x7F
0xB064	Selector HIROSE TTL OUT 1	R/W	4			
0xB068	Selector HIROSE TTL OUT 2	R/W	4			

CV-M9 GE

0xB06C	Selector Pulse Generator 0	R/ W	4	0x06:HIROSE TTL IN 3 0x07:HIROSE LVDS IN 0x09:SOFT TRIG 0 0x0D:Pulse Gen. 0 0x0E:Pulse Gen. 1 0x0F:Pulse Gen. 2 0x10:Pulse Gen. 3 0x7F:No Connection	
0xB070	Selector Pulse Generator 1	R/ W	4		
0xB074	Selector Pulse Generator 2	R/ W	4		
0xB078	Selector Pulse Generator 3	R/ W	4		Add 0x80 will result in low active output.

10. External Appearance and Dimensions

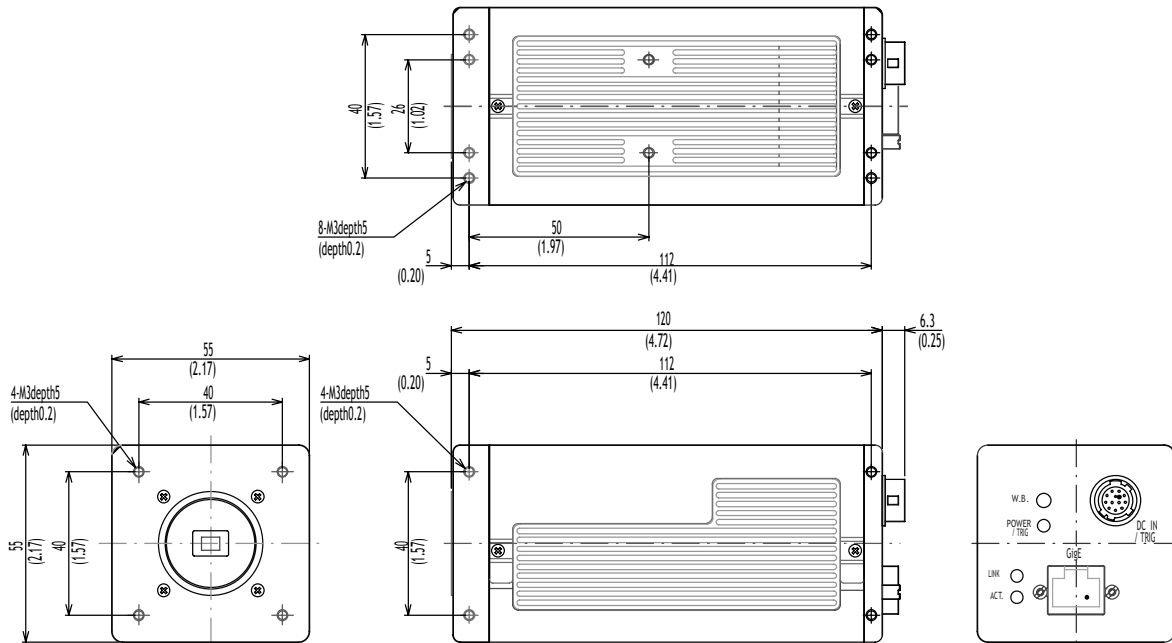

Note: Rear protrusion on C-mount lens must be less than 4.0mm

Fig. 31. Outline.

11. Specifications

11.1. Spectral response

The shown responses are for prism and CCD sensors combined.

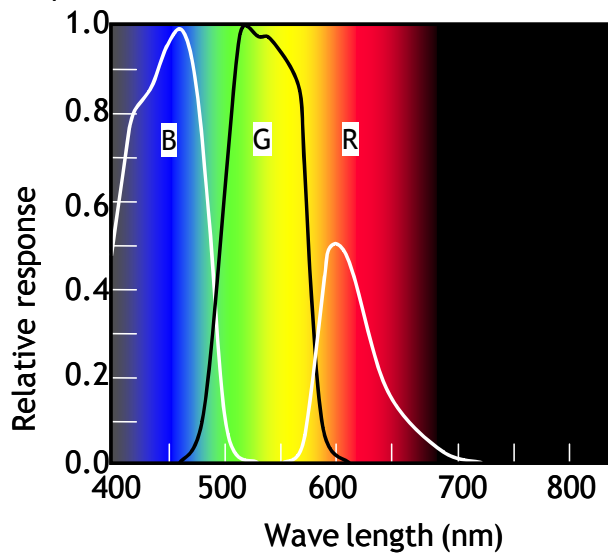

Fig. 31. Spectral response for CV-M9 GE

CV-M9 GE

11.2. Specification table

Specifications	CV-M9GE
Scanning system	Progressive
Frame rate	30 fps (792 lines per frame)
Line frequency	23.768 kHz (1420 clk per line)
V binning	19.622 kHz (1720 clk per line)
Pixel frequency	33.75 MHz
CCD sensors	3 x 1/3" IT CCD on prism. Sony ICX204AL
Sensing area	4.8 (h) x 3.6 (v) mm
Effective pixels	1034 (h) x 779 (v)
Cell size	4.65 (h) x 4.65 (v) μ m
Pixels in video output full	1024 (h) x 768 (v) 30fps. (792 lines per frame)
1/2 partial	1024 (h) x 384 (v) 48fps. (492 lines per frame)
1/4 partial	1024 (h) x 192 (v) 68fps. (384 lines per frame)
1/8 partial	1024 (h) x 96 (v) 86fps. (276 lines per frame)
V binning	1024 (h) x 384 (v) 50fps. (396 lines per frame)
Sensitivity (on sensor)	2 Lux, max gain, 50% video 8.5 Lux, 0dB gain, 100% video
S/N ratio	>50 dB. (On Green)
Video outputs.	3 x 8 bit or 3 x 10 bit RGB via Gigabit Ethernet
Iris video output	0.7 Vpp, 75 Ω w/o sync
Sync Output	EEN, FVAL, DVAL via GPIO : TTL
Gamma	1.0
Gain	Manual for all 3 colors
Gain range	Master -3 to +12 dB. R and B -6 to +6 dB
White balance	Manual/one push, continuous, Fixed 3200K, 4600K, 5600K
Tracking range	-6 to +6 dB. (2800K to 6500K)
Dynamic shading correction	Automatic
Knee correction	Knee point and slope individually for RGB
Synchronization	Int. X-tal.
GPIO functions	1) Fundamental frequency de-multiply counter 2) 20 bit counter (4 Ch) 3) LUT (Cross point switch) with 13 inputs and 7 outputs Input: LVAL, DVAL, FVAL, EEN, Hirose TTL INs, LVDS IN, Soft Trigger, Pulse Generators Output: Trigger, Hirose TTL OUTs, Pulse generators
Communication interface	Gigabit Ethernet (IEEE802.3, ATA GigE Vision Standard) Support Jumbo Frame Packet size : Available from 1418 to 8186 (Note 1)
Trigger modes	Continuous, Edge Pre-Select, Pulse Width Control, Sequence (EPS) And Delayed Readout (EPS,PWC)
Trigger function	LVAL synchronous or LVAL a-synchronous
Shutter speed (fixed).	1/30, 1/60, 1/100, 1/120, 1/120, 1/250, 1/500, 1/1000, 1/2000, 1/4000, 1/10,000 1/16,000 and 1/50,000 sec.
Programmable exposure	1/50,000s(0.5L) to 1/30s(791L). RGB common or individual (EPS only). (L=42.07 μ s.)
Pulse Width Control	>1/10,000s (2.5 L) to < 2 sec (47520L) (> 104,14 μ s to < 2s)
Operating temperature	-5°C to +45°C.
Humidity	20 - 80% non-condensing
Storage temp./humidity	-25°C to 60°C./20% - 80 % non-condensing
Vibration	3 G (15 Hz - 200 Hz in XYZ)
Shock	50 G
Regulations	CE (EN 61000-6-2, EN 61000-6-3) FCC part 15 class B
Power	12V DC \pm 10%. < 0.8A
Lens mount	C-mount. (Max 4.0 mm thread)
Flange back	17.526mm +0 -0.05mm
Optical axis	Centre \pm 0.1mm
Dimensions	55 x 55 x 121 mm (HxWxD)
Weight	800 g

Note 1 : Packet size being usable should follow the following formula.

- | | | |
|-----------------------------|---------------------------|----------------|
| 1) For both 8bit and 10 bit | Packet size = 36 + 24 x n | 58 < n < 338 |
| 2) For 8 bit only | Packet size = 36 + 6 x n | 232 < n < 1359 |
| 3) For 10 bit only | Packet size = 36 + 8 x n | 174 < n < 1019 |

Note: Above specifications are subject to change without notice

12. Appendix

12.1. Precautions

Personnel not trained in dealing with similar electronic devices should not service this camera. The camera contains components sensitive to electrostatic discharge. The handling of these devices should follow the requirements of electrostatic sensitive components.

Do not attempt to disassemble this camera.

Do not expose this camera to rain or moisture.

Do not face this camera towards the sun, extreme bright light or light reflecting objects.

When this camera is not in use, put the supplied lens cap on the lens mount.

Handle this camera with the maximum care.

Operate this camera only from the type of power source indicated on the camera.

Remove power from the camera when changing switch settings.

12.2. Typical Sensor Characteristics

The following effects may be observed on the video monitor screen. They do not indicate any fault of the camera, but do associate with typical sensor characteristics.

V. Aliasing

When the CCD camera captures stripes, straight lines or similar sharp patterns, jagged image on the monitor may appear.

Blemishes

All cameras are shipped without visible CCD sensor blemishes.

Over time some pixel defects can occur. This does not have a practical effect on the operation of the camera. These will show up as white spots (blemishes).

Exposure to cosmic rays can cause blemishes to appear on the CCD sensor. Please take care to avoid exposure to cosmic rays during transportation and storage. It is recommended using sea shipment instead of air flight in order to limit the influence of cosmic rays to camera.

Pixel defects/blemishes also may emerge due to prolonged operation at elevated ambient temperature, due to high gain setting or during long time exposure. It is therefore recommended to operate the camera within its specifications.

Patterned Noise

When the sensor captures a dark object at high temperature or is used for long time integration, fixed pattern noise may appear on the video monitor screen.

Caution when mounting a lens on the camera

When mounting a lens on the camera dusts particles in the air may settle on the surface of the lens or the prism of the camera. It is therefore important to keep the protective caps on the lens and the camera until the lens is mounted. Point the lens mount of the camera downward to prevent dust particles from landing on the optical surfaces of the camera. This work should be done in a dust free environment. Do not touch any of the optical surfaces of the camera or the lens.

Exportation

When exporting this product, please follow the export regulation of your own country.

12.3. References

1. This manual can for CV-M9 GE can be downloaded from www.jai.com
2. Datasheet for CV-M9 GE can be downloaded from www.jai.com
3. Specifications for the CCD sensor Sony ICX-204AL can be found on www.jai.com

Index

A		I	
Auto Iris Lens	21	inter-packet delay	17
B		L	
Basic functions	17	Lens mount	4, 38
binning	3, 25, 26, 29, 34, 38	LVDS	5, 7, 8, 9, 38
Bit Allocation	15	N	
Blemishes	39	network interface cards (NICs)	16
C		P	
CAMERA TRIGGER	7	partial scan	20, 24, 25
CAT 6 Ethernet	3	Pin Assignment	5
CCD sensors	3, 4, 15, 37, 38	Pixel Type	15
continuous	3, 16, 18, 21, 27, 30, 38	Progressive Scan	0, 3
Continuous Mode	27	Pulse Generators	6
D		Pulse Width Control	27, 28, 29, 32, 36, 38
Delayed Readout Mode	2, 34	PWC . 14, 19, 20, 21, 27, 28, 29, 32, 33, 34, 35, 36, 38	
dichroic prism	3	R	
E		Register	12, 13, 14, 18, 20, 33, 34
Edge Pre-select	27, 29, 30, 36	ROI	19, 33
Electronic Shutter	18, 20	S	
EPS . 12, 13, 19, 20, 21, 27, 28, 29, 30, 33, 34, 36, 38		SDK	3, 9, 18, 33, 34
Exposure Time Abs	20	Sequential Trigger	27, 33, 34
F		Software Development Kit	3
Filter Driver	3	Spectral response	37
G		Switches/Routers	16
GenlCam	3, 19, 20	T	
Gigabit Ethernet ... 3, 5, 16, 17, 22, 30, 32, 38		Trigger mode	30, 32, 33
GigE Vision compliant	16	TTL IN	5, 8, 9, 14
GigE Vision standard	3, 16, 17	TTL OUT	5, 7, 9
GigE Vision Streaming Protocol	15	V	
GPIO (General Purpose Input and Output)	6	Vertical binning	22, 25, 30, 32
GPIO programming examples	12	X	
H		XML	3
Hirose	4, 5, 7, 8, 9, 14, 16, 30, 32, 38		

13. User's Record

Camera type: CV-M9GE
Revision:
Serial No.
Firmware version.

For camera revision history, please contact your local JAI distributor.

User's Mode Settings.

User's Modifications.



DECLARATION OF CONFORMITY
AS DEFINED BY THE COUNCIL DIRECTIVE
89/336/EEC
EMC (ELECTROMAGNETIC COMPABILITY)
WE HEREWITH DECLARE THAT THIS PRODUCT
COMPLIES WITH THE FOLOWING PROVISIONS APPLYING TO IT.
EN-61000-6-2
EN-61000-6-3

Company and product names mentioned in this manual are trademarks or registered trademarks of their respective owners.
JAI A-S cannot be held responsible for any technical or typographical errors and reserves the right to make changes to products and documentation without prior notification.

Europe, Middle East & Africa

Phone +45 4457 8888
Fax +45 4491 8880

Asia Pacific

Phone +81 45 440 0154
Fax +81 45 440 0166

Americas

Phone (toll-free) +1 800 445 5444
Phone +1 408 383 0300

Visit our web site at www.jai.com



See the possibilities