



C6 Series

# 3D Sensors

# TAILORED

# SOLUTIONS

## 3D Laser Line Profilers

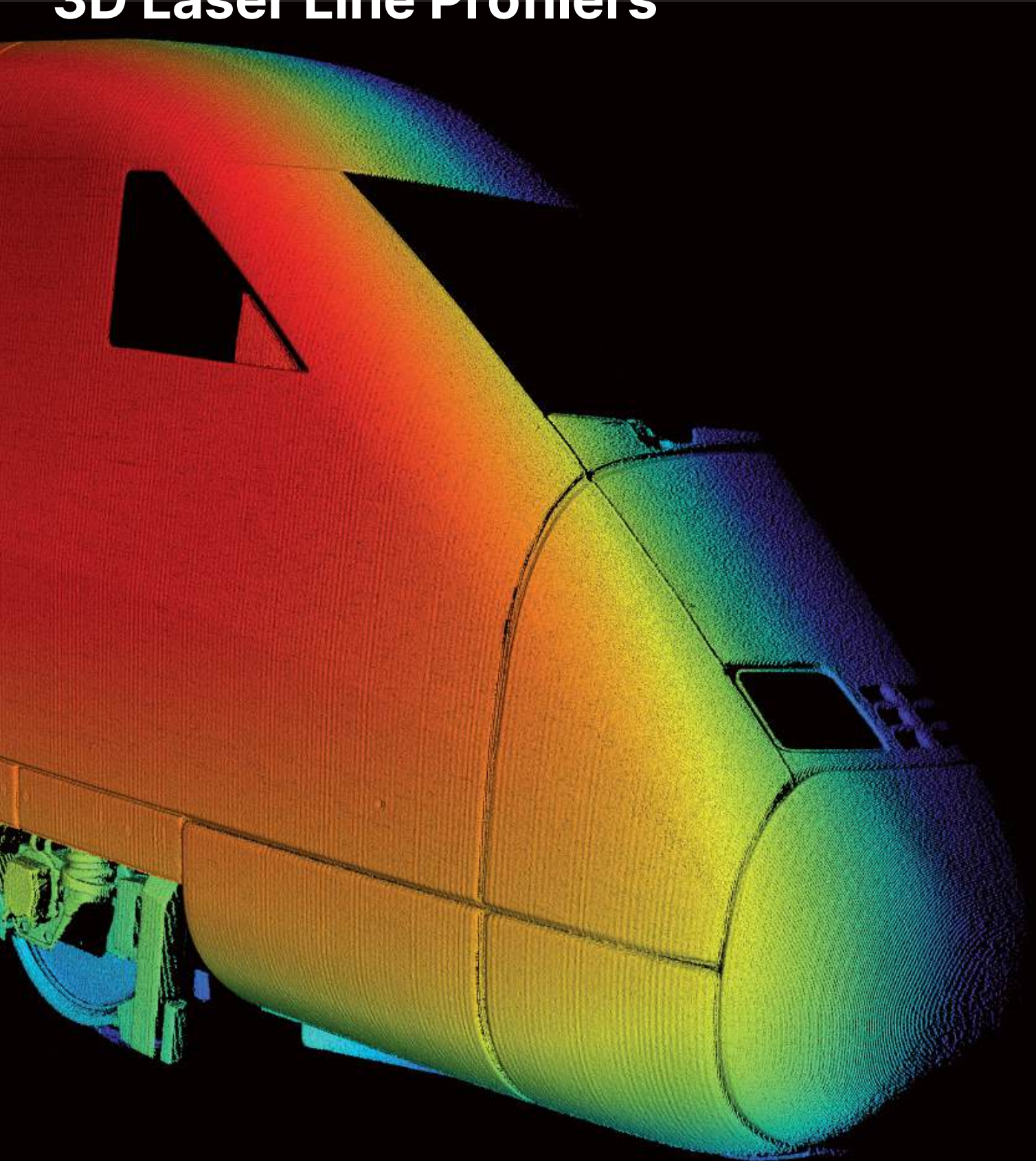

### 3D Vision Portfolio

The new C6 Series of 3D sensors from AT is based on a new sensor platform that supports the latest industry standard GigE Vision / GenICam 3D with 1 Gbit/s. The new laser profilers offer an impressive combination of extremely high-speed and high-precision resolution, enabling the C6 Series to enter worlds that 3D imaging has not seen before. They feature profile resolution up to 4096 points per profile and profile speed up to 140 kHz as well as high dynamic range 3D image acquisition. Available as compact sensor, MCS and 3D camera.

#### Compact Sensors (CS)



- ✓ Factory calibrated 3D sensors
- ✓ Wide range of models with X-FOV 7 - 1290 mm
- ✓ Four different sensor resolutions available (1280, 2040, 3070, 4090)
- ✓ High industrial protection class IP67
- ✓ Available with various laser configurations
- ✓ Resolution Z up to 0.2  $\mu$ m

#### Modular Compact Sensors (MCS)



- ✓ Factory assembled and calibrated 3D laser triangulation sensors consisting of sensor module, laser module and link module
- ✓ Customized 3D sensor designs without NRE or MOQ
- ✓ Four different sensor resolutions available (1280, 2040, 3070, 4090)
- ✓ Configurable according to application requirements like X-FOV, working distance, triangulation angle, number of points per profile, laser wavelength and laser safety class
- ✓ Dual-Head configuration possible for occlusion-free 3D scans
- ✓ High industrial protection class IP67

#### 3D Cameras



- ✓ Designed for flexible laser triangulation setups with user-defined lasers and lenses
- ✓ Four different sensor resolutions available (1280, 2040, 3070, 4090)
- ✓ High industrial protection class IP67
- ✓ Available with various lens mounts and Scheimpflug adapters
- ✓ Lens protection tubes



# KEY FACTS

## By Professionals for Professionals

### Highest Resolution

- ✓ Profile resolution up to 4096 points/profile
- ✓ Sophisticated 3D laser line detection algorithms for every application (FIR-PEAK, MAX, COG, TRSH)
- ✓ Resolution X: up to 5  $\mu\text{m}$
- ✓ Resolution Z: up to 0.2  $\mu\text{m}$

### Unique Features

- ✓ GenICam 3.0: support of latest 3D standards
- ✓ MultiPart: parallel output of different features (e.g. range, reflectance, scatter) at maximum profile speed with optimized pixel formats
- ✓ MultiPeak: output of up to four different peaks for even more robust 3D data and for scanning transparent or shiny objects
- ✓ Region search and tracking: automatically finds and tracks the laser line in the detector image

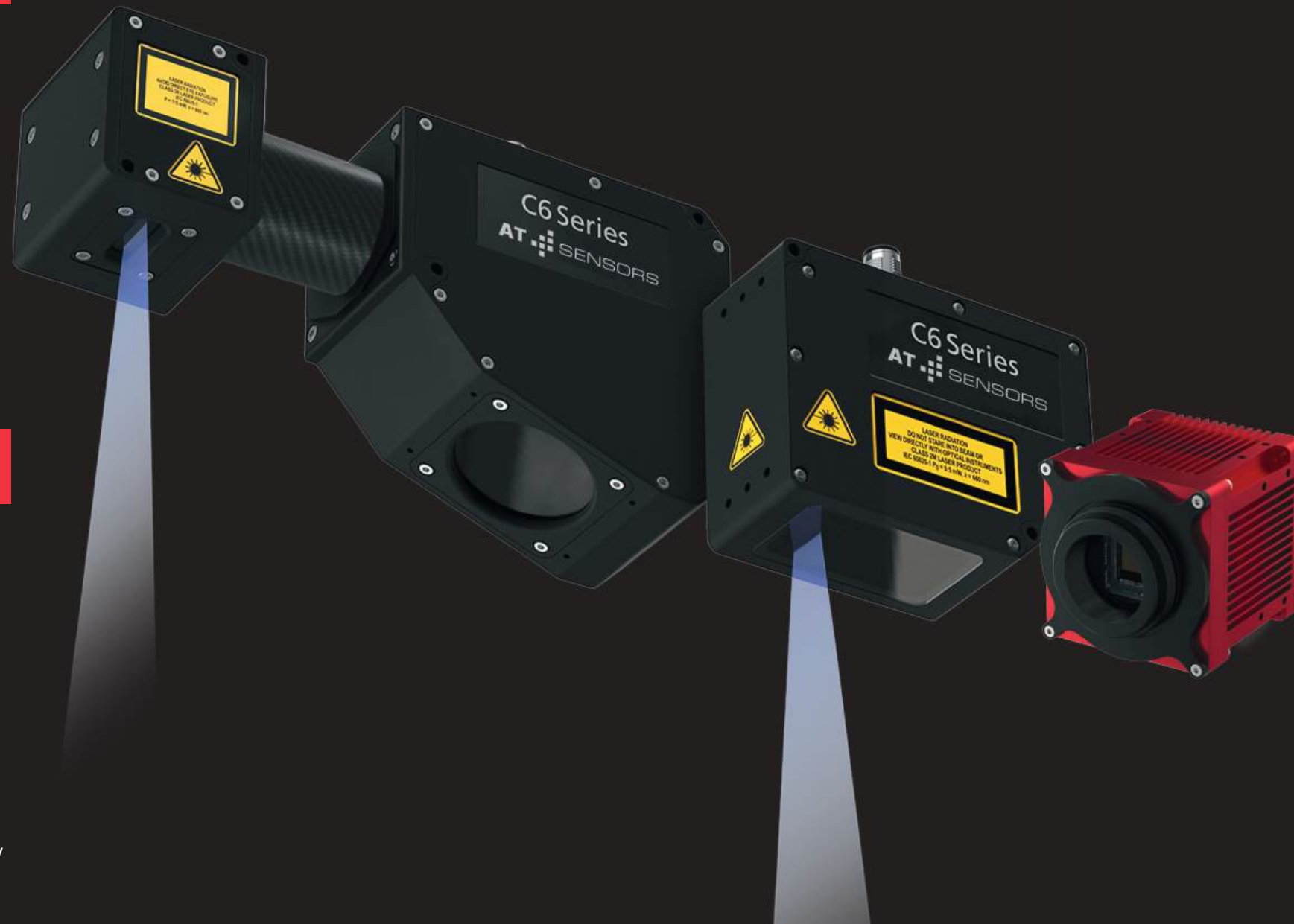

### Unmatched Profile Speed

- ✓ Profile speed up to 140 kHz
- ✓ 3D data rate up to 128 million 3D points per second
- ✓ Increase profile speed by defining detector regions
- ✓ Support up to four regions

### Various Models

- ✓ Wide range of compact sensors with X-FOV 7 - 1290 mm and numerous laser configurations
- ✓ Wide range of detectors with different resolutions (1280 - 4096 pixel/profile)

### Modular Concept

- ✓ Modular Compact Sensors (MCS): individual design optimized for your requirements
- ✓ No additional development costs
- ✓ No minimum order quantity
- ✓ Short delivery time



# 3070 SENSOR CHIP

World's Fastest 3D Image Sensor

## WARP Speed

- ✓ Widely Advanced Rapid Profiling (WARP)
- ✓ Unmatched profile speed
- ✓ Three different speed levels

## On-Chip Processing

- ✓ Internal processing speed of 29 gigapixels/s
- ✓ 3D profile pixel output rate of 128 megapixels/s

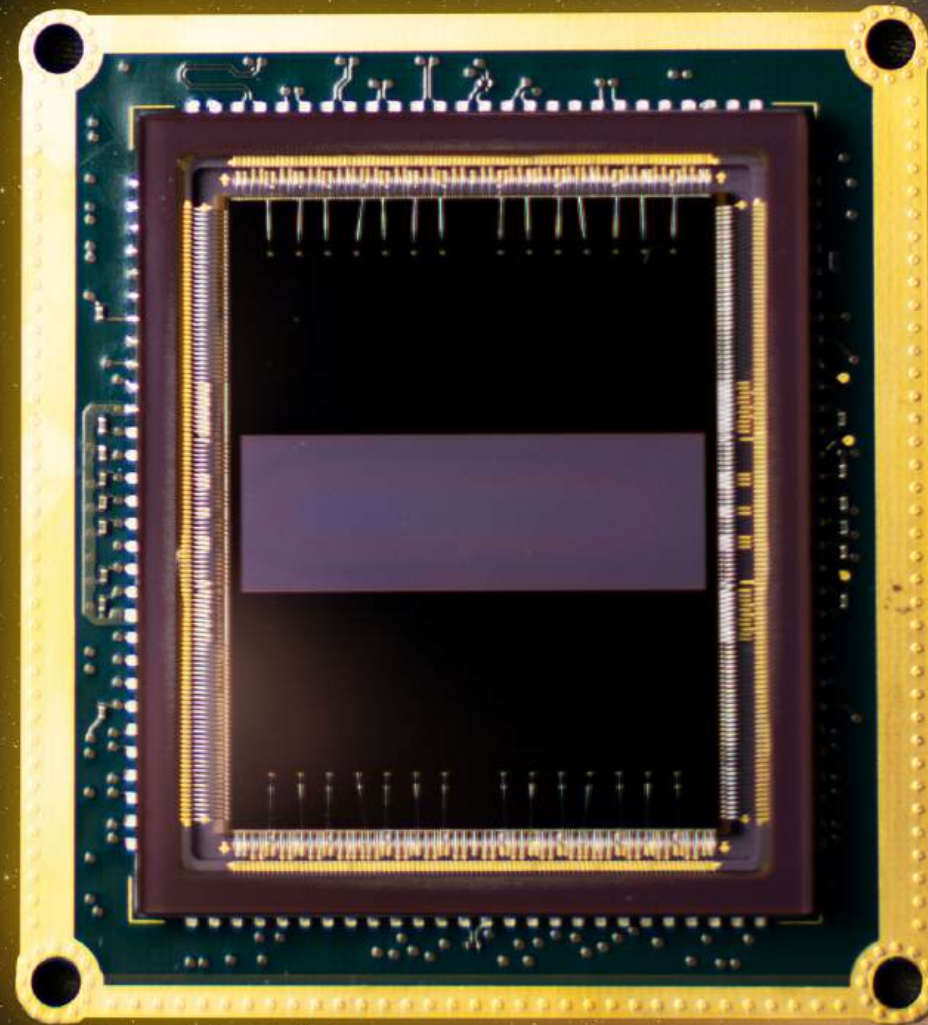

## AT's Sensor Technology

- ✓ Exclusive 3K imager design developed by AT
- ✓ High sensitivity and high dynamic range pixel design
- ✓ Integrated on-chip processing

## World's Fastest Profiling

- ✓ Worldwide fastest 3D image sensor in the combination of speed and resolution
- ✓ Intelligent line detection algorithms with advanced filtering and validation for highly accurate scans

# Ten Times Faster 3D Scans



# APPLICATION VARIETY

## Suitable for All Industries



**Battery Inspection**

- ✓ Inspection of the inner foil structure of the battery during assembly
- ✓ Inspection of the electrical contact surface of the battery



**Logistics & Packaging**

- ✓ Sealing inspection
- ✓ Package quality inspection

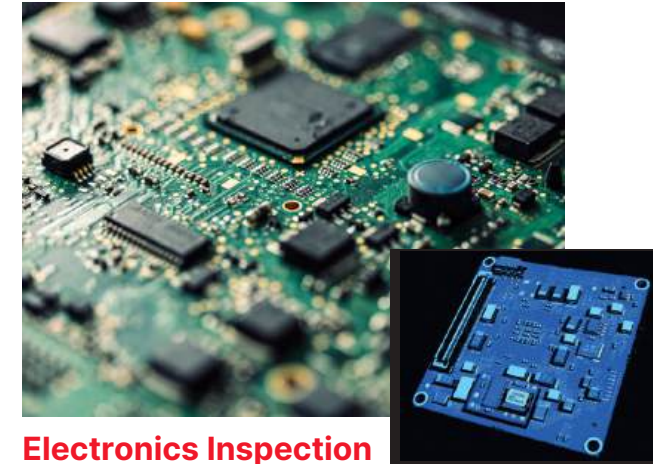

**Electronics Inspection**

- ✓ PCB Automated Optical Inspection (AOI)
- ✓ Solder Paste Inspection (SPI)



**Food & Beverages**

- ✓ Inline food packaging inspection
- ✓ Foodbranding, decoration, counting and volume measurement

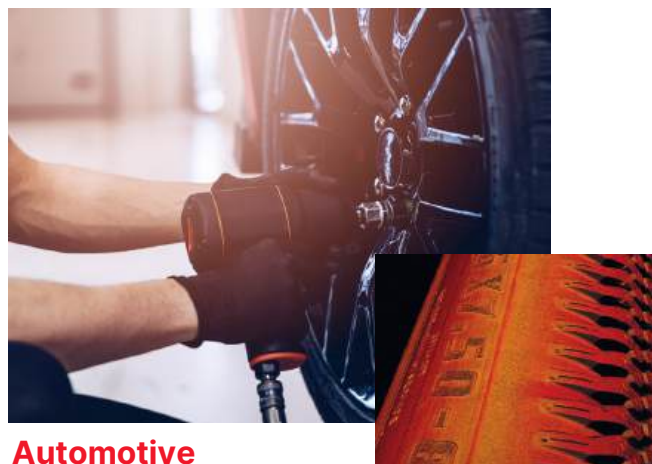

**Automotive**

- ✓ Tire inspection
- ✓ Electric vehicle motor assembly inspection



**Wood & Lumber**

- ✓ Sawmill production optimization
- ✓ Wood furniture quality inspection

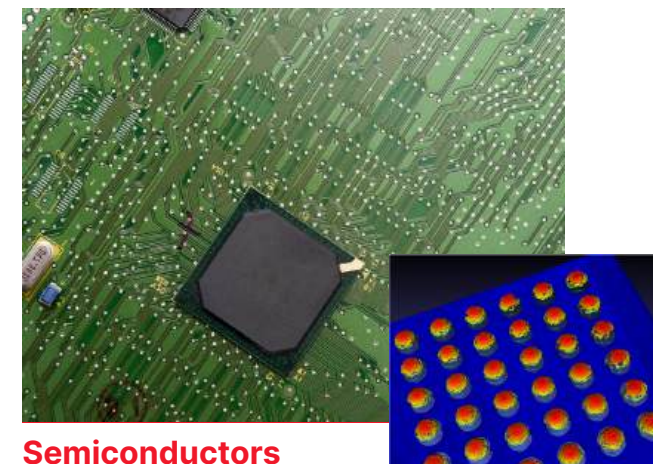

**Semiconductors**

- ✓ Inspection of electronic components (BGA, QFP)
- ✓ Silicon wafer inspection



**Metrology**

- ✓ Inspection of dimensional properties and geometrical features
- ✓ Comparison to the CAD model



# INTEGRATE

## AT SolutionPackage

# EASILY

The AT SolutionPackage consists of a variety of tools that can be used to acquire 3D images, configure the 3D camera and provide 3D data in the form of range maps or point clouds and more. This package is a software add-on to our 3D products.

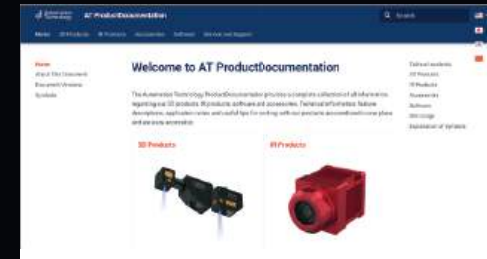

### AT ProductDocumentation

- ✓ Complete documentation for all AT products including full support
- ✓ Easy accessible HTML documentation
- ✓ Offline version included

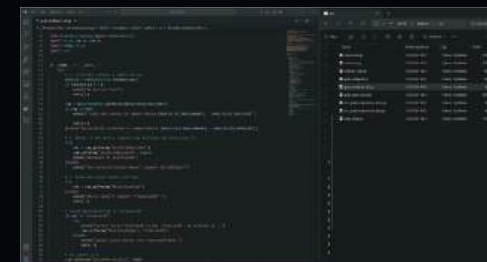

### cxSDK

- ✓ SDK for image acquisition and camera configuration
- ✓ SDK for intrinsic and extrinsic calibration
- ✓ 3D point cloud and ZMap generation

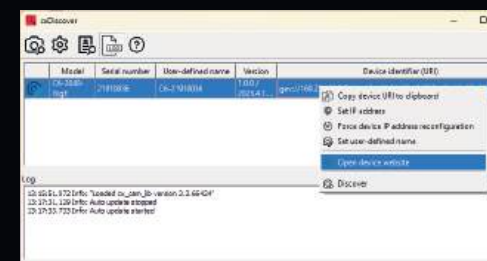

### cxDiscover

- ✓ GigE Vision device discovery tool
- ✓ Network settings configuration

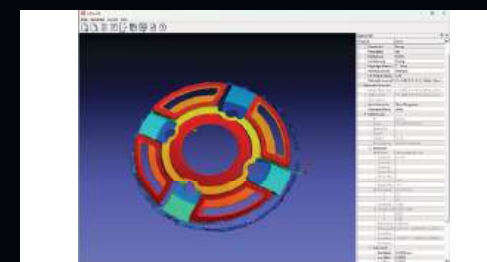

### cxShow3D

- ✓ Sample tool with GUI for 3D point cloud visualization and ZMap generation

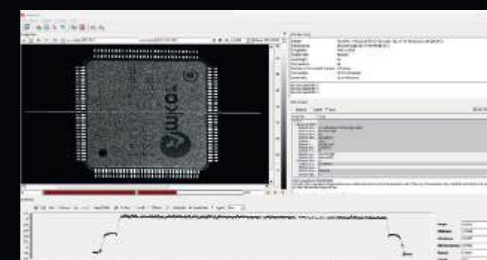

### cxExplorer

- ✓ Software for 3D image acquisition, device configuration and data analysis

# AT 3D SENSOR SERIES

## Overview

### ESSENTIAL



CS

- ✓ Large selection of field of views
- ✓ Five different sensor models available

**Typical Industries:** Automotive, Logistics & Packaging, Wood & Lumber, Pharma, Robotics & Automation, Iron & Steel

### BUDGET



ECS

- ✓ Optimal price-performance ratio
- ✓ Cost-efficient

**Typical Industries:** Food & Beverage, Logistics & Packaging, Robot Vision

### PERFORMANCE



XCS

- ✓ Extremely high resolution
- ✓ High-quality laser line projection
- ✓ No occlusion with dual-head option

**Typical Industries:** Electronics, Semicon

### CUSTOMIZATION



CAMERAS

- ✓ Compatible with custom components
- ✓ Optimal for complex multi-sensor applications
- ✓ Available with different Scheimpflug configurations

**Typical Industries:** Iron & Steel, Plastics, Robotics & Automation

### FLEXIBILITY



MCS

- ✓ Modular sensor concept for individual solutions
- ✓ No extra costs, short delivery time and no minimum order quantities

**Typical Industries:** Automotive, Logistics & Packaging, Wood & Lumber, Pharma, Robotics & Automation, Iron & Steel, Plastics, Transportation, Metrology, Sorting & Recycling

### COMPACTNESS



CORES

- ✓ Ideal for integration in OEM devices
- ✓ Different sensor and laser modules available

**Typical Industries:** OEM specific



# COMPACT

## Sensors



### Compact Sensors

- ✓ Factory calibrated 3D sensors
- ✓ Wide range of models with X-FOV 7 - 1290 mm
- ✓ Four different sensor resolutions available (1280, 2040, 3070, 4090)
- ✓ High industrial protection class IP67
- ✓ Available with various laser configurations
- ✓ Resolution Z up to 0.2  $\mu\text{m}$

### Product Overview

#### 3D Compact Sensor Housing Model G6

- ✓ Profile resolution up to 2048 points / profile
- ✓ Profile speed up to 140 kHz
- ✓ Wide range of models with X-FOV 7 - 53 mm
- ✓ Nominal working distance: 31 - 90 mm
- ✓ Resolution X: 5 - 26  $\mu\text{m}$
- ✓ Resolution Z: 0.2 - 1.2  $\mu\text{m}$
- ✓ Z-Range 5 - 46 mm
- ✓ Linearity Z: +/-0.01 % of Z-Range
- ✓ Repeatability Z: 0.1 - 0.5  $\mu\text{m}$



#### 3D Compact Sensor Housing Model G1

- ✓ Profile resolution up to 2048 points / profile
- ✓ Profile speed up to 140 kHz
- ✓ Wide range of models with X-FOV 29 - 160 mm
- ✓ Nominal working distance: 106 - 197 mm
- ✓ Resolution X: 19 - 78  $\mu\text{m}$
- ✓ Resolution Z: 0.8 - 5.9  $\mu\text{m}$
- ✓ Z-Range 40 - 80 mm
- ✓ Linearity Z: +/-0.01 % of Z-Range
- ✓ Repeatability Z: 0.4 - 6.6  $\mu\text{m}$



#### 3D Compact Sensor Housing Model G5

- ✓ Profile resolution up to 4096 points / profile
- ✓ Profile speed up to 25 kHz
- ✓ Wide range of models with X-FOV 82 and 145 mm
- ✓ Nominal working distance: 172 mm
- ✓ Resolution X: 20 - 35  $\mu\text{m}$
- ✓ Resolution Z: 0.5 - 0.9  $\mu\text{m}$
- ✓ Z-Range 15 mm
- ✓ Linearity Z: +/-0.01 % of Z-Range
- ✓ Repeatability Z: 0.4 - 0.7  $\mu\text{m}$



#### 3D Compact Sensor Housing Model G3

- ✓ Profile resolution up to 4096 points / profile
- ✓ Profile speed up to 140 kHz
- ✓ Wide range of models with X-FOV 182 - 1290 mm
- ✓ Nominal working distance: 400 - 944 mm
- ✓ Resolution X: 44 - 586  $\mu\text{m}$
- ✓ Resolution Z: 1.4 - 35.3  $\mu\text{m}$
- ✓ Z-Range 250 - 1090 mm
- ✓ Linearity Z: +/-0.01 % of Z-Range
- ✓ Repeatability Z: 2.1 - 10.0  $\mu\text{m}$





# Specifications

Housing Model G6									
Model Name	Nominal X-FOV	Z-Range	Nominal Working Distance	Resolution X (μm)	Resolution Z (μm)	Points per Profile	Profile Speed (kHz)	Laser Wavelength (nm)	Laser Safety Class
C6-1280CS35-7	7 mm (0.27 in)	5.2 mm (0.20 in)	31 mm (1.22 in)	5	0.2	1280	140	405, 450	2M, 3R, 3B
C6-1280CS35-12	12 mm (0.47 in)	8 mm (0.31 in)	31 mm (1.22 in)	10	0.2	1280	140	405, 450	2M, 3R, 3B
C6-1280CS25-20	20 mm (0.78 in)	20 mm (0.78 in)	72 mm (2.83 in)	16	0.5	1280	140	405, 450	2M, 3R, 3B
C6-1280CS21-40	40 mm (1.57 in)	46 mm (1.81 in)	90 mm (3.54 in)	31	1.2	1280	140	405	2M, 3R, 3B
C6-2040CS21-53	53 mm ( 2.08 in)	46mm (1.81 in)	90 mm (3.54 in)	26	1	2048	25	405	2M, 3R, 3B

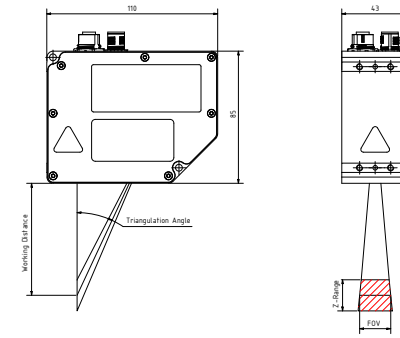

**Housing Model G6**

Housing Model G1									
Model Name	Nominal X-FOV	Z-Range	Nominal Working Distance	Resolution X (μm)	Resolution Z (μm)	Points per Profile	Profile Speed (kHz)	Laser Wavelength (nm)	Laser Safety Class
C6-1280CS23-29	29 mm (1.14 in)	40 mm (1.57 in)	106 mm (4.17 in)	23	0.8	1280	140	405, 660	2M, 3R, 3B
C6-2040CS23-38	38 mm (1.49 in)	30 mm (1.18 in)	106 mm (4.17 in)	19	0.7	2048	25	405, 660	2M, 3R, 3B
C6-1280CS23-47	47 mm (1.85 in)	40 mm (1.57 in)	106 mm (4.17 in)	37	1.4	1280	140	405, 660	2M, 3R, 3B
C6-2040CS23-63	63 mm (2.48 in)	40 mm (1.57 in)	106 mm (4.17 in)	31	1.2	2048	25	405, 660	2M, 3R, 3B
C6-1280CS23-75	75 mm (2.95 in)	40 mm (1.57 in)	106 mm (4.17 in)	59	2.3	1280	140	405, 660	2M, 3R, 3B
C6-1280CS14-76	76 mm (2.99 in)	80 mm (3.14 in)	197 mm (7.75 in)	59	3.5	1280	140	405, 660	2M, 3R, 3B
C6-2040CS14-100	100 mm (3.93 in)	120 mm (4.72 in)	197 mm (7.75 in)	49	2.9	2048	25	405, 660	2M, 3R, 3B
C6-2040CS23-100	100 mm (3.93 in)	60 mm (2.36 in)	106 mm (4.17 in)	49	1.9	2048	25	405, 660	2M, 3R, 3B
C6-1280CS14-120	120 mm (4.72 in)	120 mm (4.72 in)	197 mm (7.75 in)	94	5.9	1280	140	405, 660	2M, 3R, 3B
C6-2040CS14-160	160 mm (6.29 in)	80 mm (3.14 in)	197 mm (7.75 in)	78	4.9	2048	25	405, 660	2M, 3R, 3B

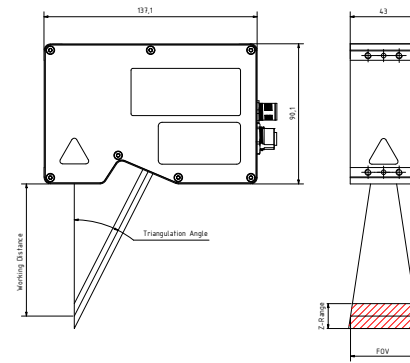

**Housing Model G1**

Housing Model G5									
Model Name	Nominal X-FOV	Z-Range	Nominal Working Distance	Resolution X (μm)	Resolution Z (μm)	Points per Profile	Profile Speed (kHz)	Laser Wavelength (nm)	Laser Safety Class
C6-4090CS39-82	82 mm (3.22 in)	15 mm (0.59 in)	172 mm (6.77 in)	20	0.5	4096	20	405, 660	2M, 3R, 3B
C6-4090CS39-145	145 mm (5.70 in)	15 mm (0.59 in)	172 mm (6.77 in)	35	0.9	4096	20	405, 660	2M, 3R, 3B

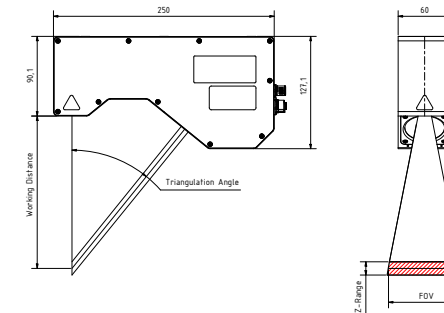

**Housing Model G5**

Housing Model G3									
Model Name	Nominal X-FOV	Z-Range	Nominal Working Distance	Resolution X (μm)	Resolution Z (μm)	Points per Profile	Profile Speed (kHz)	Laser Wavelength (nm)	Laser Safety Class
C6-4090CS30-182	182 mm (7.16 in)	150 mm (6.25 in)	400 mm (15.74 in)	44	1.4	4096	25	405, 660	2M, 3R, 3B
C6-1280CS30-248	248 mm (9.76 in)	200 mm (7.87 in)	400 mm (15.74 in)	194	6.1	1280	140	405, 660	2M, 3R, 3B
C6-4090CS30-288	288 mm (11.33 in)	250 mm (9.84 in)	400 mm (15.74 in)	70	2.2	4096	25	405, 660	2M, 3R, 3B
C6-2040CS30-330	330 mm (12.99 in)	200 mm (7.87 in)	400 mm (15.74 in)	161	5.0	2048	25	405, 660	2M, 3R, 3B
C6-2040CS18-1060	1060 mm (41.73 in)	800 mm (31.49 in)	744 mm (29.29 in)	518	26.2	2048	25	405, 660	2M, 3R, 3B
C6-2040CS15-1290	1290 mm (50.78 in)	1090 mm (42.91 in)	920 mm (36.22 in)	630	38.0	2048	25	405, 660	2M, 3R, 3B

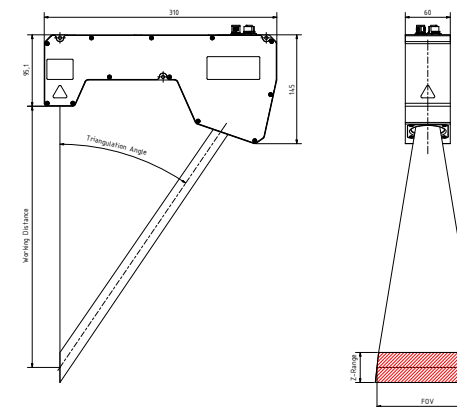

**Housing Model G3**



# MODULAR

## Compact Sensors



### Modular Compact Sensors (MCS)

- ✓ Factory assembled and calibrated 3D laser triangulation sensors consisting of sensor module, laser module and link module
- ✓ Customized 3D sensor designs without NRE or MOQ
- ✓ Four different sensor resolutions available (1280, 2040, 3070, 4090)
- ✓ Configurable according to application requirements like X-FOV, working distance, triangulation angle, number of points per profile, laser wavelength and laser safety class
- ✓ Dual-Head configuration possible for occlusion-free 3D scans
- ✓ High industrial protection class IP67

### Product Overview

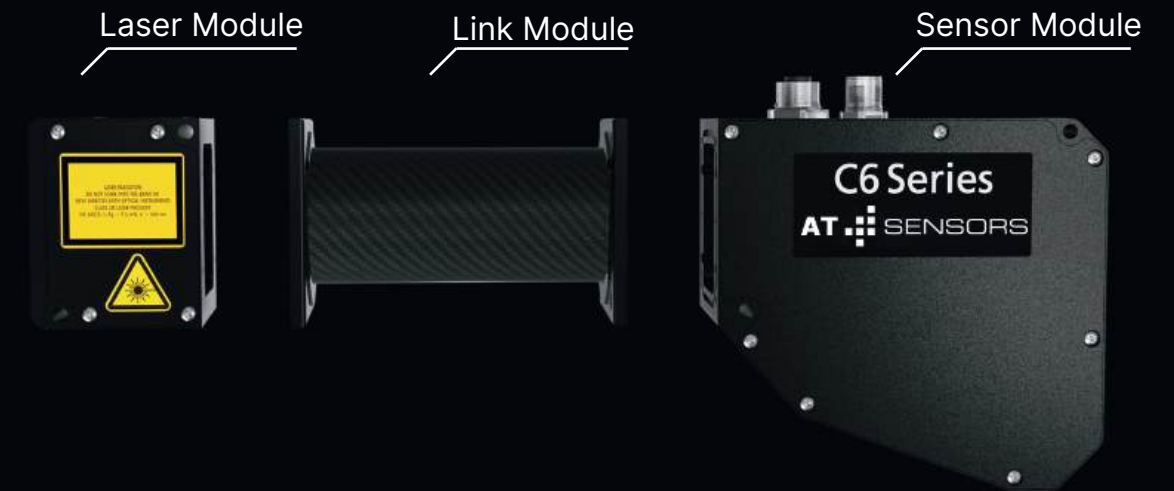

Factory assembled and calibrated 3D laser triangulation sensors consisting of:

- ✓ Sensor module
- ✓ Laser module
- ✓ Link module

Configurable according to application requirements:

- ✓ X-FOV
- ✓ Working distance
- ✓ Triangulation angle
- ✓ Number of points per profile
- ✓ Laser wavelength
- ✓ Laser safety class

### 3D Modular Compact Sensors MCS

- ✓ Number of points per profile: 1280, 2048, 3072 and 4096
- ✓ X-FOV: 70 – 1600 mm
- ✓ Triangulation angle: 15°, 20°, 25°, 30° and 40°
- ✓ Resolution X: up to 17  $\mu\text{m}$
- ✓ Resolution Z: up to 1  $\mu\text{m}$
- ✓ Profile speed: up to 140 kHz

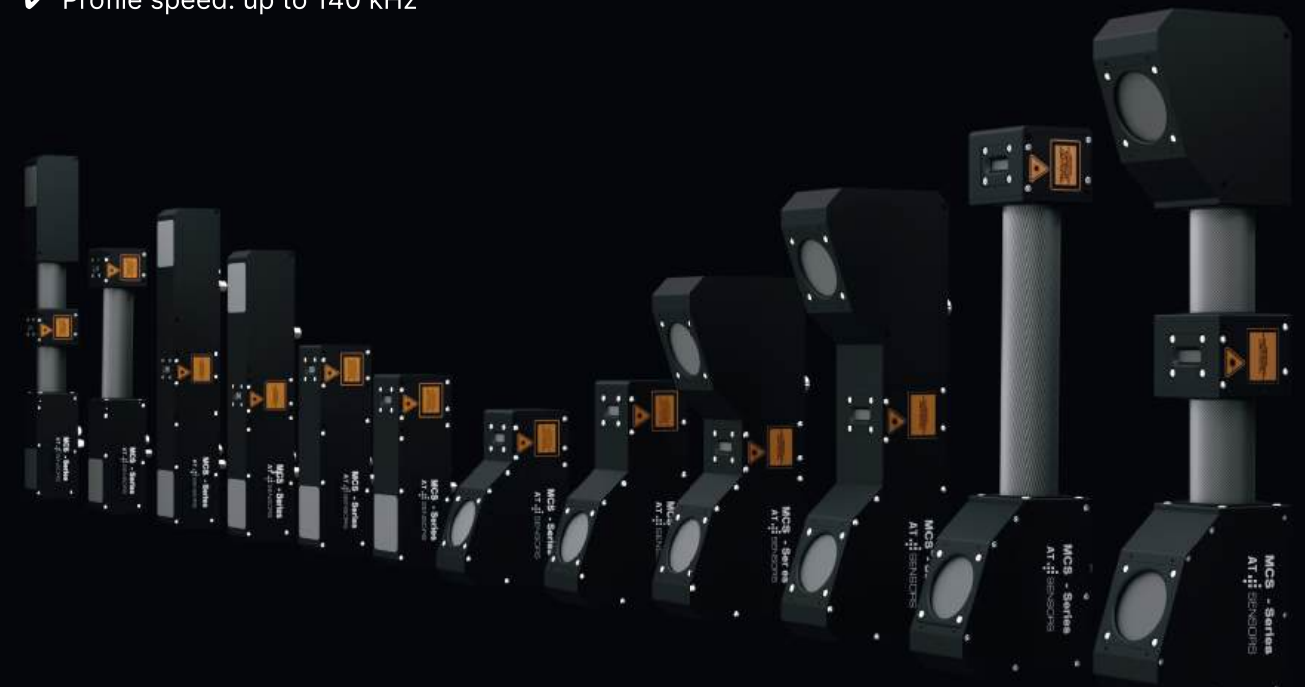



# MCS

## with High Laser Power



### Product Overview

<b>X Field of View</b>	up to 2800 mm
<b>Lateral X Resolution</b>	down to 50 µm
<b>Working Distance</b>	up to 1700 mm
<b>Nominal Triangulation Angle</b>	15°
<b>Profile Resolution</b>	3072, 4096 points
<b>Profile Speed</b>	up to 140 kHz
<b>Available Sensor Modules</b>	3070, 3070W (WARP), 4090

### Laser Specification

<b>Laser Wavelength</b>	405, 450, 660, 760, 808 nm (more on request)
<b>Laser Power</b>	up to 1700 mW (higher power on request)
<b>Laser Class</b>	3R, 3B

### General Specification

<b>Interface</b>	Gigabit Ethernet (1GigE)
<b>Inputs</b>	<ul style="list-style-type: none"> <li>Encoder A+, A-, B+, B-, Z+, Z- (TTL level)</li> <li>Two freely configurable digital inputs (+5 to +24 VDC)</li> </ul>
<b>Outputs</b>	Two freely configurable digital outputs (+5 to +24 VDC)
<b>Power Supply</b>	<ul style="list-style-type: none"> <li>Sensor supply +10 to +24 VDC (max. +27 VDC)</li> <li>Laser supply +10 to +24 VDC</li> </ul>
<b>Housing</b>	Anodized aluminum, IP67
<b>Environmental Conditions</b>	<ul style="list-style-type: none"> <li>Operating temperature 0 °C to +40 °C</li> <li>Storage temperature -20 °C to +80 °C</li> <li>Humidity 20 % to 80 % (non-condensing)</li> </ul>
<b>Vibration/Shock Ratings</b>	<ul style="list-style-type: none"> <li>Vibration resistance (sinusoidal): DIN EN 60068-2-6:2008-10: 2g, 10-150 Hz</li> <li>Vibration resistance (random): DIN EN 60068-2-64:2020-09: 7g, 10-500 Hz</li> <li>Shock resistance: DIN EN 60068-2-27: 2010-02: 15g, 3ms</li> </ul>
<b>Communication Protocols</b>	<ul style="list-style-type: none"> <li>GenICam</li> <li>GigE Vision</li> </ul>
<b>Firmware Features</b>	Automatic RegionTracking, Automatic RegionSearch, Multiple Regions, MultiPart, AutoStart, HistoryBuffer, MultiSlope, MultiPeak

### Modular Compact Sensors (MCS) with High Laser Power

- ✓ based on AT's unique modular 3D laser triangulation sensor concept
- ✓ World's fastest 3D profiling
- ✓ Intelligent data compression directly on the sensor chip
- ✓ Up to ten times faster 3D scans
- ✓ Profile speed up to 140 kHz
- ✓ High laser power through laser class 3R/3B
- ✓ Large field of view of up to 2800 mm

### Recommended Applications:

- Road Pavement Scanning
- Inspection of cold or red-hot steel parts
- Scanning of railroad infrastructure





# XCS

## Sensors

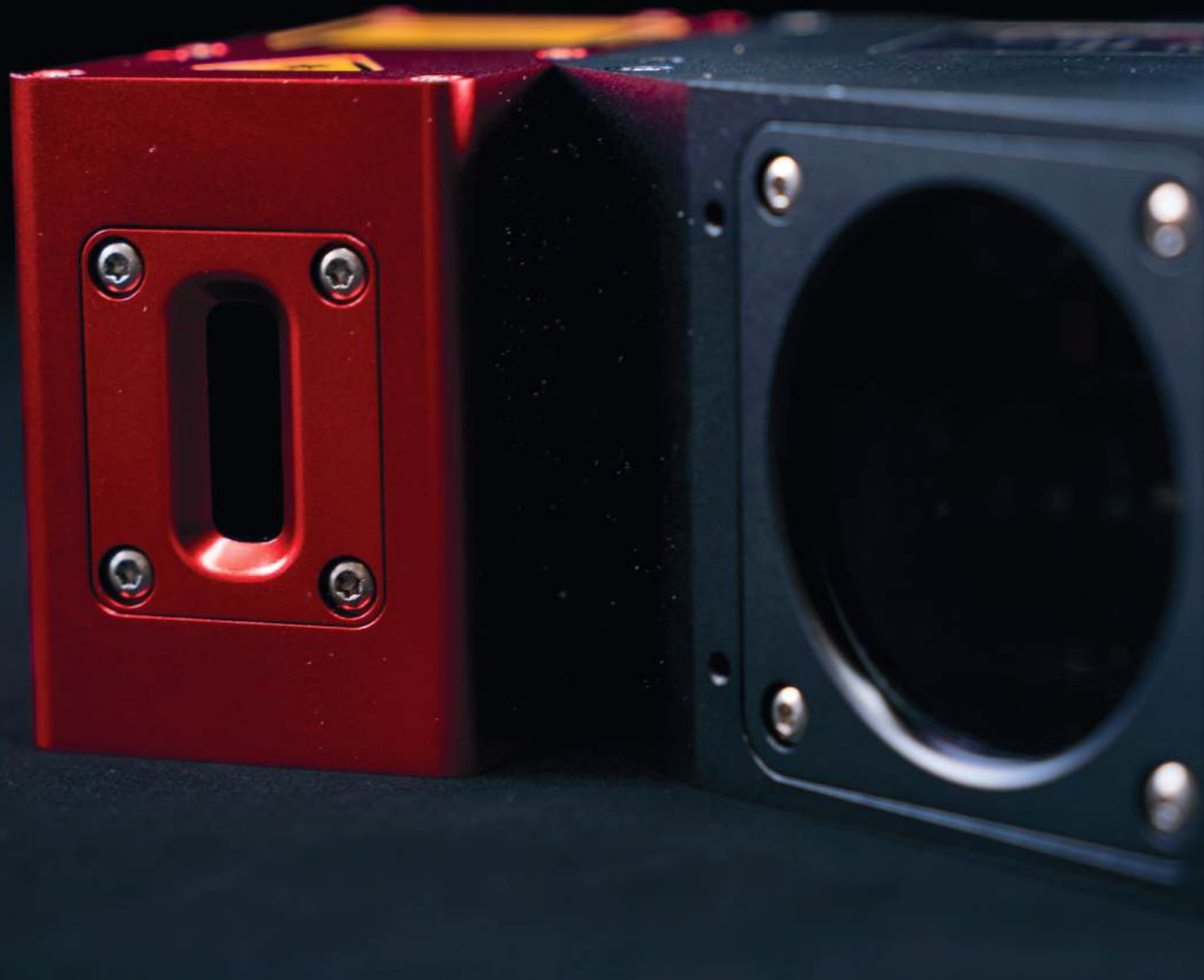

### Product Overview

#### Available Models:

##### 3070 WARP:

- ✓ 602344999 / C6-3070W-XCS-48-146-D-405-3R
- ✓ 602345000 / C6-3070W-XCS-48-146-S-405-3R

##### 3070:

- ✓ 602345001 / C6-3070-XCS-48-146-D-405-3R
- ✓ 602345002 / C6-3070-XCS-48-146-S-405-3R

##### 4090:

- ✓ 602344997 / C6-4090-XCS-53-146-D-405-3R
- ✓ 602344998 / C6-4090-XCS-53-146-S-405-3R

#### Application Recommendations:

- ✓ Electronics & Semicon
- ✓ E-Mobility & Battery
- ✓ Automotive Metrology
- ✓ Industrial Automation
- ✓ Welding
- ✓ Pharmaceuticals
- ✓ Wood & Lumber

#### Single-Head



#### Dual-Head



### XCS Series

- ✓ Unique 3D scan results without occlusion due to dual-head option and extremely high profile speed at 3072 or 4096 points per profile
- ✓ High precision and repeatability thanks to high-quality laser line projection
- ✓ Unrivalled optical resolution for electronic inspection (e.g. BGA inspection) with a field of view of up to 53 mm
- ✓ Highest inspection speed available with 3070 WARP sensor



## General Specifications for all XCS Models

<b>Interface</b>	Gigabit Ethernet (1GigE)
<b>Inputs</b>	<ul style="list-style-type: none"> <li>Encoder A+, A -, B+, B -, Z+, Z- (TTL Level)</li> <li>Two freely configurable digital inputs (+5 to +24 VDC)</li> </ul>
<b>Outputs</b>	Two freely configurable digital outputs (+5 to +24 VDC)
<b>Power Supply</b>	<ul style="list-style-type: none"> <li>Sensor supply +10 to +24 VDC (max. +27 VDC )</li> <li>Laser supply +10 to +24 VDC</li> </ul>
<b>Housing</b>	Anodized aluminum, IP67
<b>Environmental Conditions</b>	<ul style="list-style-type: none"> <li>Operating temperature 0 °C to +40 °C</li> <li>Storage temperature -20 °C to +80 °C</li> <li>Humidity 20% to 80%</li> </ul>
<b>Vibration/Shock</b>	<ul style="list-style-type: none"> <li>Vibration resistance (sinusoidal): DIN EN 60068-2-6: 2008-10: 2g, 10-150 Hz</li> <li>Vibration resistance (random): DIN EN 60068-2-64: 2020-09: 7g, 10-500 Hz</li> <li>Shock resistance: DIN EN 60068-2-27: 2010-02: 15g, 3ms</li> </ul>
<b>Communication Protocols</b>	GenICam, GigE Vision
<b>Features</b>	Automatic RegionTracking, Automatic RegionSearch, Multiple Regions, MultiPart, AutoStart, History Buffer, Multi-Slope, MultiPeak

## Laser Specifications for all XCS Models

<b>Laser Wavelength</b>	405 nm
<b>Laser Class</b>	3R

## Models 3070 / 3070 WARP

<b>Part Number / Model Name</b>	602344999 / C6-3070W-XCS-48-146-D-405-3R 602345000 / C6-3070W-XCS-48-146-S-405-3R 602345001 / C6-3070-XCS-48-146-D-405-3R 602345002 / C6-3070-XCS-48-146-S-405-3R
---------------------------------	--

## Optical Setup 3070 / 3070 WARP

<b>Lateral Resolution X</b>	0.016 mm
<b>Height Resolution Z</b>	0.5 µm (with 6 subpixels)
<b>Working Distance</b>	146 mm
<b>X-Field of View</b>	48 mm
<b>Profile Resolution</b>	3072 pixel per profile
<b>Profile Speed</b>	max. 140 kHz, 14.5 kHz @ full Z-Range
<b>Z-Range Near to Far</b>	20 mm

## Models 4090

<b>Part Number / Model Name</b>	602344997 / C6-4090-XCS-53-146-D-405-3R 602344998 / C6-4090-XCS-53-146-S-405-3R
---------------------------------	--

## Optical Setup 4090

<b>Lateral Resolution X</b>	0.013 mm
<b>Height Resolution Z</b>	0.42 µm (with 6 subpixels)
<b>Working Distance</b>	146 mm
<b>X-Field of View</b>	53 mm
<b>Profile Resolution</b>	4096 pixel per profile
<b>Profile Speed</b>	max. 20.3 kHz
<b>Z-Range Near to Far</b>	10 mm

## Technical Drawings Dual-Head

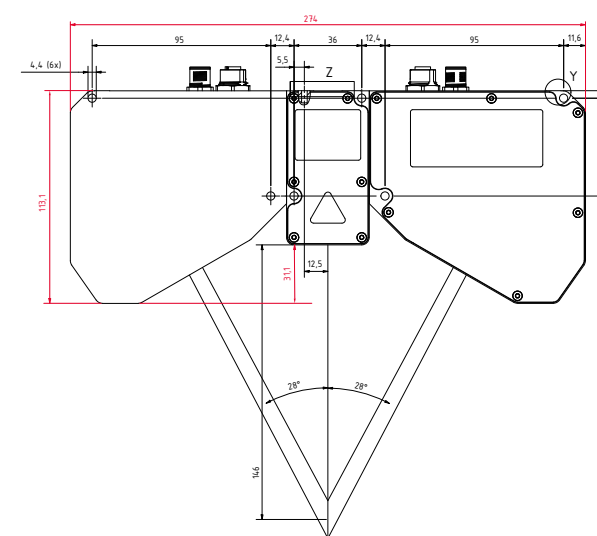

XCS 3070 / 3070 WARP

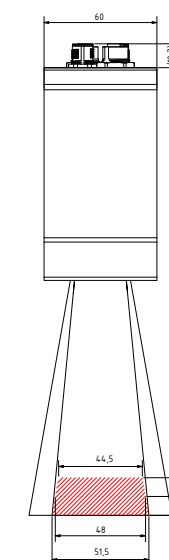

XCS 4090

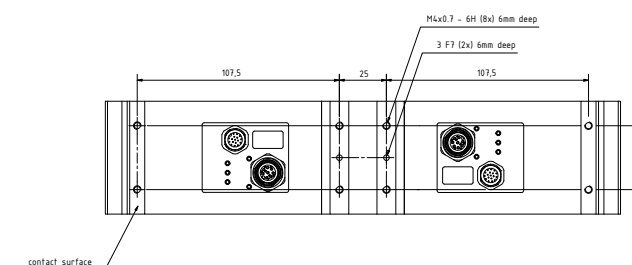
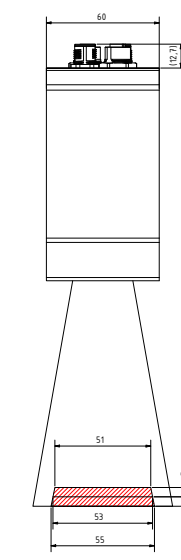

## Technical Drawings Single-Head

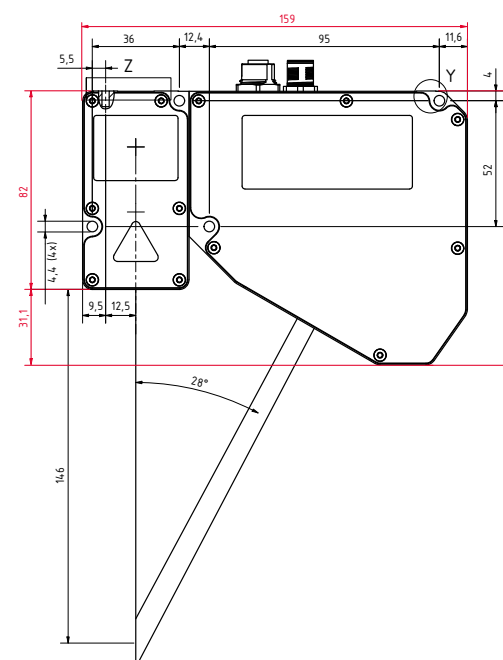

XCS 3070 / 3070 WARP

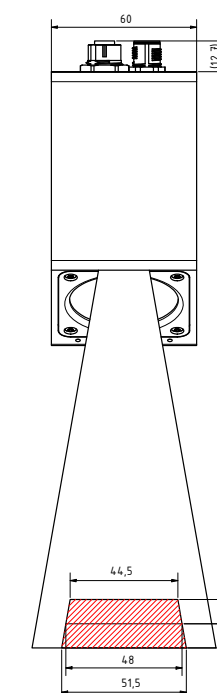

XCS 4090

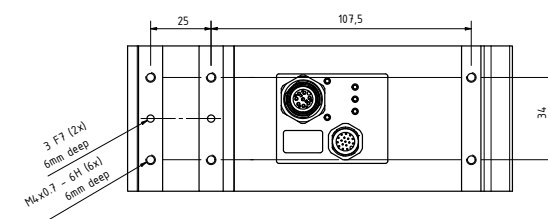
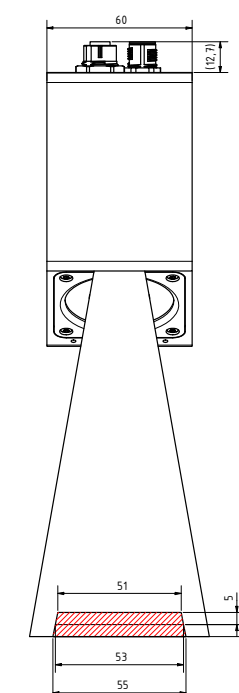



# ECS

## Eco Compact Sensor



### Product Overview

#### Models

Model Name	Points	Working Distance (mm)	X Range Nominal (mm)	Z Range (mm)	X Resolution Nominal (μm)	Z Resolution Nominal (μm)	Profile Speed at 200 rows	Max. Profile Speed
C6-S7-2040-ECS-23-100-106-SX-1G-660-2M	2048	106	102	60	49	1.9	1.8 kHz	25 kHz
C6-S7-2040-ECS-14-160-197-SX-1G-660-2M	2048	197	162	120	78	4.9	1.8 kHz	25 kHz
C6-S7-4090-ECS-30-288-400-SX-1G-660-2M	4096	400	284	250	71	2.1	2 kHz	24 kHz
C6-S7-4090-ECS-18-575-740-SX-1G-660-2M	4096	744	575	500	140	7.0	2 kHz	24 kHz

#### Technical Data

<b>Laser Wavelength</b>	660 nm
<b>Laser Safety Class IEC</b>	2M
<b>Interface</b>	Gigabit-Ethernet
<b>Inputs</b>	<ul style="list-style-type: none"> <li>Encoder A+, A -, B+, B -, Z+, Z- (TTL Level)</li> <li>Two freely configurable digital inputs (+5 to +24 VDC)</li> </ul>
<b>Outputs</b>	Two freely configurable digital outputs (+5 to +24 VDC)
<b>Power Supply</b>	<ul style="list-style-type: none"> <li>Sensor supply +10 to +24 VDC (max. +27 VDC )</li> <li>Laser supply +10 to +24 VDC</li> </ul>
<b>Housing</b>	Anodized aluminum , IP54
<b>Environmental Conditions</b>	<ul style="list-style-type: none"> <li>Operating temperature 0 ° C to +40 ° C</li> <li>Storage temperature 20 ° C to +80 ° C</li> <li>Humidity 20 % to 80 %</li> </ul>
<b>Vibration/Shock</b>	<ul style="list-style-type: none"> <li>Vibration resistance (sinusoidal): DIN EN 60068-2-6: 2008-10: 2 g, 10-150 Hz</li> <li>Vibration resistance (random): DIN EN 60068-2-64: 2020-09: 7 g, 10-500 Hz</li> <li>Shock resistance: DIN EN 60068-2 27: 2010 02: 15 g, 3 ms</li> </ul>
<b>Standards</b>	GenICam, GigE Vision
<b>Features</b>	Automatic Region-Tracking, Automatic Region-Search, Multiple Regions, MultiPart, AutoStart, History Buffer, Multi-Slope, MultiPeak

#### Technical Drawings

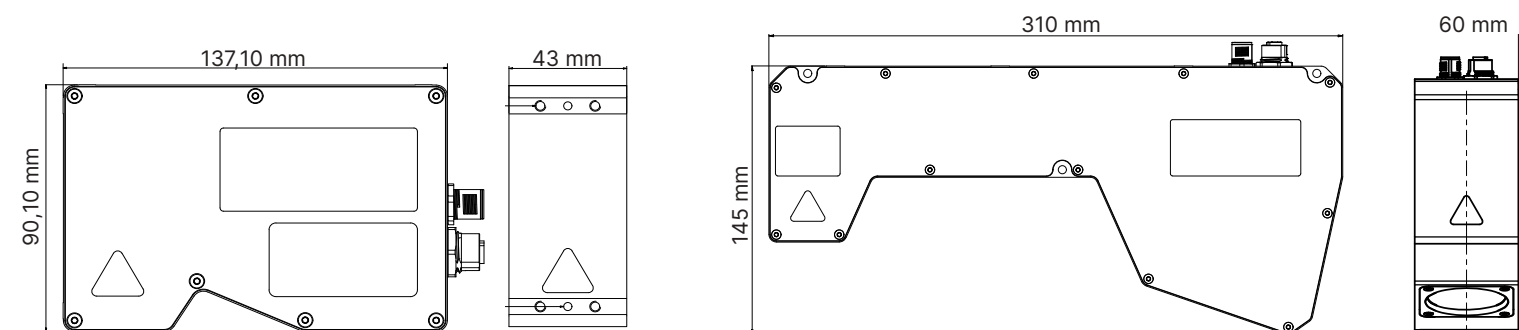

#### ECS Series

- ✓ Price-performance ratio: Cost-effective 3D sensor for demanding applications
- ✓ Software standards for easy integration: GigE Vision, GenICam, and third-party software support
- ✓ Cross-industry application: Ideal for the food industry, logistics, and robot vision

# CAMERA

## For Laser Triangulation



### 3D Cameras

- ✓ Designed for flexible laser triangulation set-ups with user-defined lasers and lenses
- ✓ Four different sensor resolutions available (1280, 2040, 3070, 4090)
- ✓ High industrial protection class IP67
- ✓ Available with various lens mounts and Scheimpflug adapters
- ✓ Lens protection tubes

### Product Overview

Designed for flexible laser triangulation set-ups with user-defined lasers and lenses.

#### Available Models:

- ✓ C6-1280-GigE: 1280 x 1024 pixels
- ✓ C6-2040-GigE: 2048 x 1088 pixels
- ✓ C6-3070-GigE: 3072 x 1020 pixels
- ✓ C6-3070-WARP-GigE: 3072 x 1020 pixels with WARP
- ✓ C6-4090-GigE: 4096 x 3072 pixels

#### Standard Lens Mount Version with M42x1

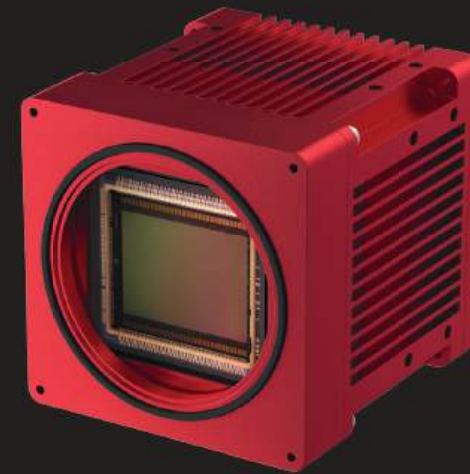

#### Version with Optional C-Mount Adapter

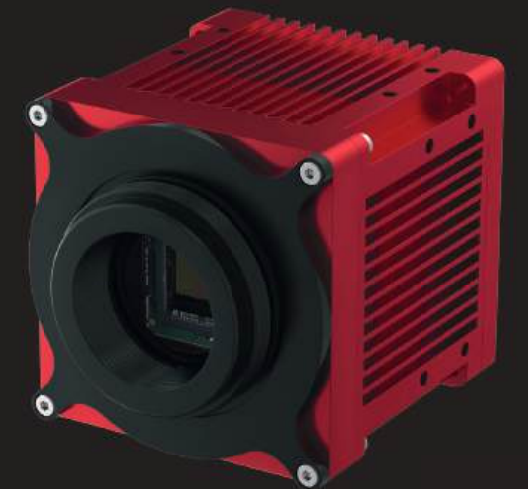



# Specifications

Model Name	C6-1280-GigE			C6-2040-GigE		C6-3070-GigE / C6-3070-WARP-GigE			C6-4090-GigE	
Sensor Resolution	1280 × 1024			2048 × 1088		3072 × 1020			4096 × 3072	
Pixel Size	6.6 μm x 6.6 μm			5.5 μm x 5.5 μm		6.6 μm x 6.6 μm			5.5 μm x 5.5 μm	
Dynamic Range (*with HDR-3D)	90 dB			90 dB		90 dB			90 dB	
Digitization	10 Bit			10 Bit		10 bit			10 Bit	
Sensitivity	9.6 V/lux.s @ 525 nm			5.56 V/lux.s @ 550 nm		8 V/lux.s @ 525 nm			4.64 V/lux.s @ 550 nm	
Sensor Algorithm	MAX, TRSH, COG, FIR-PEAK			MAX, TRSH, COG, FIR-PEAK		MAX, TRSH, COG, FIR-PEAK			MAX, TRSH, COG, FIR-PEAK	
Profile Length in 3D Mode	1280 Pixels per Profile			2048 Pixels per Profile		3072 Pixels per Profile			4096 Pixels per Profile	
Typical Profile Speed Depending on Number of Sensor Rows	Sensor Rows	Profile Speed in kHz		Sensor Rows	Profile Speed in kHz (with 3072 Pixels)		Sensor Rows	Profile Speed in kHz (with 4096 Pixels)		
		(with 1280 Pixels)	(with 688 Pixels)		(with 2048 Pixels)	C6-3070-GigE	C6-3070-WARP-GigE			
Height resolution can be increased by using TRSH (1/2 Pixel) or COG/FIR-PEAK (1/64 Pixel) without loss of speed	1024	1.1	1.9	1024	0.3	1.0	9.2	3072	0.2	
	256	4.3	7.7	256	1.4	384	22.9	512	0.9	
	128	8.5	15.1	128	2.6	192	42.1	128	3.1	
	32	32.8	54.2	32	9.7	48	88.9*	32	9.7	
	16	63.0	95.7	16	16.0	12	47.9*	16	14.9	
	8	116.0*	155.2	8	25.0	6	66.5*	8	20.3	

\*limited due to the 1 Gbit/s interface, faster profile rates are possible with upcoming NBASE-T interface

General C6 Camera Specifications	
Interface Specifications	
Digital Input	2 Electrical Isolated Inputs (5-24 V DC)
Digital Outputs	2 Electrical Isolated Outputs (5-24 V DC)
Encoder / Resolver Input	High-Speed Resolver Interface with Signals A, /A, B, /B, Z, /Z
Analog Output	Range: 0-5 V DC
Data Interface	GigE Vision with GenICam Protocol
Power Requirements	
Power Supply	10 - 24V DC
Power Consumption	max. 12 W
Mechanical Specifications	
Lens Mount	M42×1 / optional with C-Mount or F-Mount Adapter
Size	55 mm x 55 mm x 55 mm (2.16 × 2.16 × 2.16 in)
Mass (without Lens & Adaptor)	200 g
Housing Mount	M3 + Adaptor Plate with Metric and Inch Threads
Environmental Specifications	
Operating Temperature	0°C to +50°C (32 to +122 °F) (Non-Condensing)
Storage Temperature	-30°C to +70°C (-22 to +158 °F)
General	
PC Requirements	Gigabit Ethernet NIC
Operating Systems	Windows 10 /11, Linux

## With Default Lens Mount M42×1

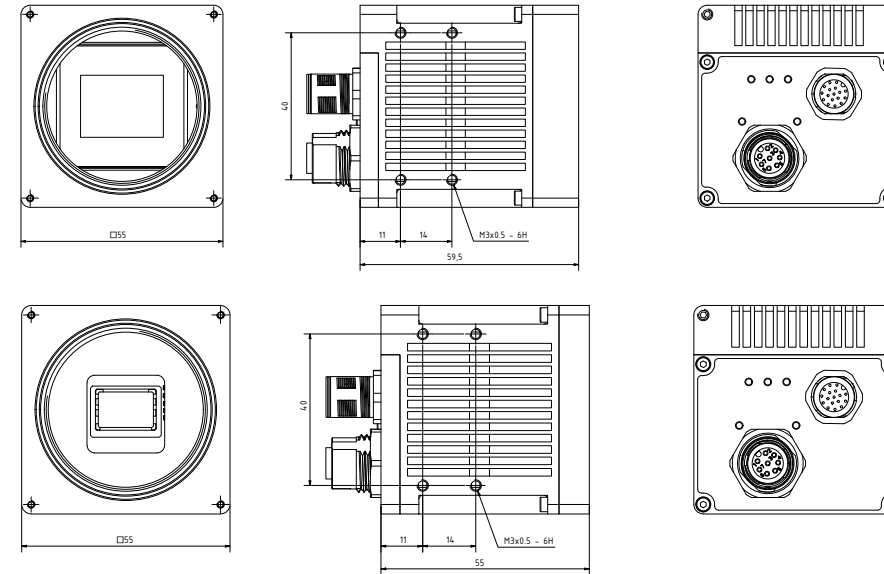

**C6-4090-GigE**

**C6-1280-GigE  
C6-2040-GigE  
C6-3070-GigE  
C6-3070-WARP-GigE**

## With C-Mount Adapter

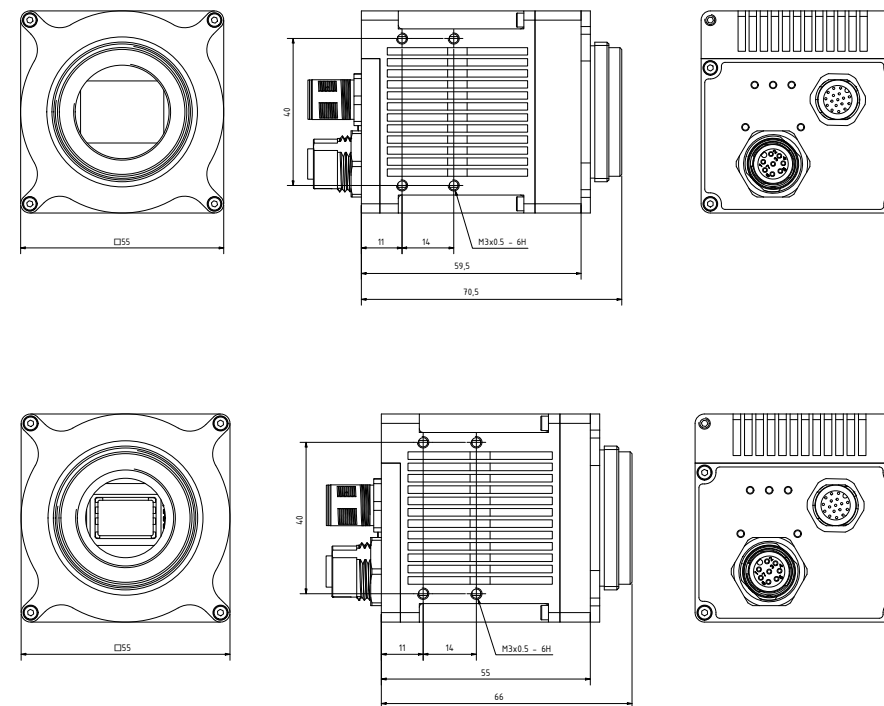

**C6-4090-GigE**

**C6-1280-GigE  
C6-2040-GigE  
C6-3070-GigE  
C6-3070-WARP-GigE**

# EVALUATE RAPIDLY

## AT Metrology Package

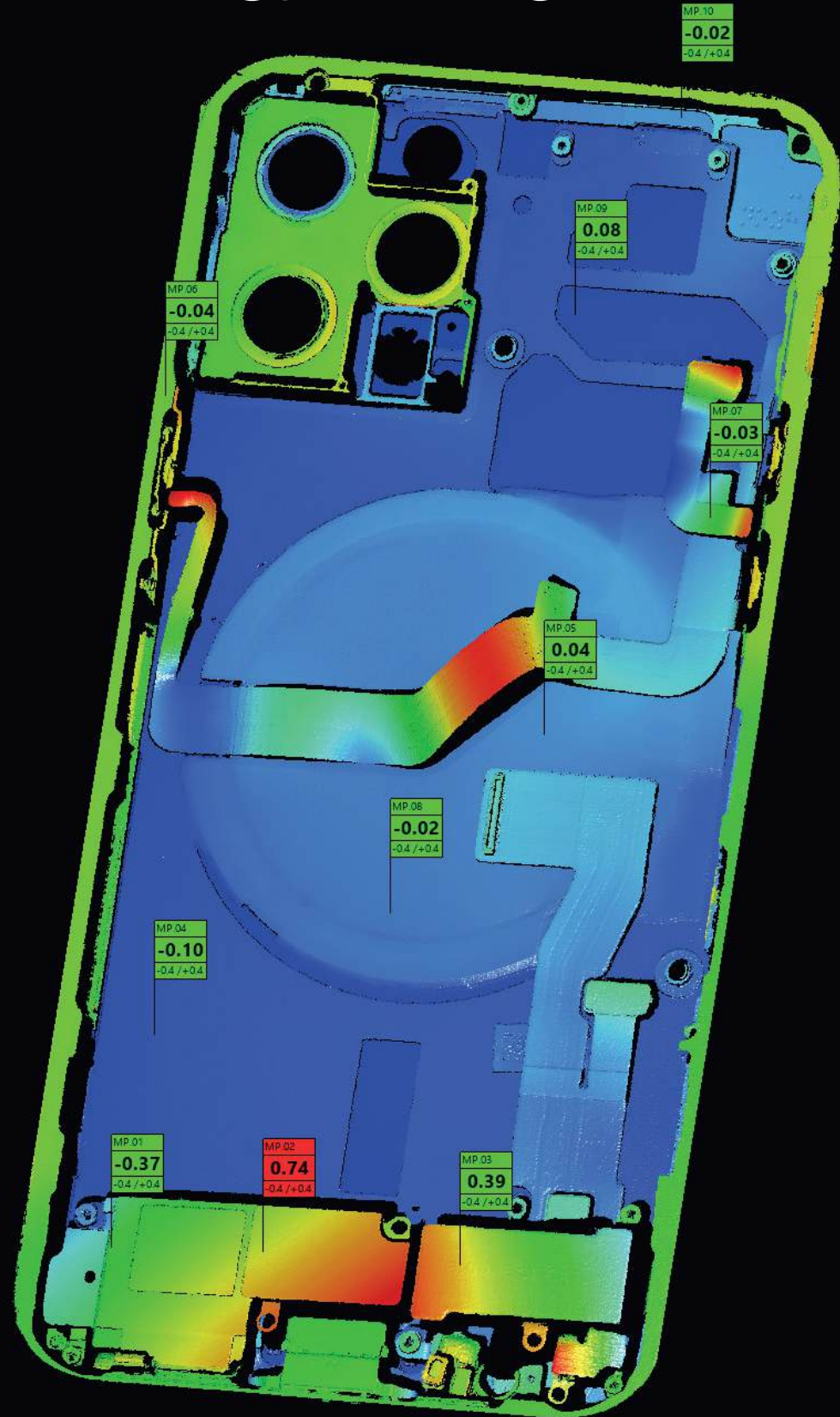

### Our Smart 3D Software Add-on

- ✓ Easy to use software package for super-fast prototyping and deployment
- ✓ Simplified multi-sensor calibration
- ✓ Inline inspection per Reference Point System (RPS)
- ✓ Intelligent algorithms for 3D point cloud processing
- ✓ Includes GUI tool, source code and 3D sample data
- ✓ Basic version is free of charge
- ✓ Comprehensive developer version and runtime license available

### Metrology Application Examples

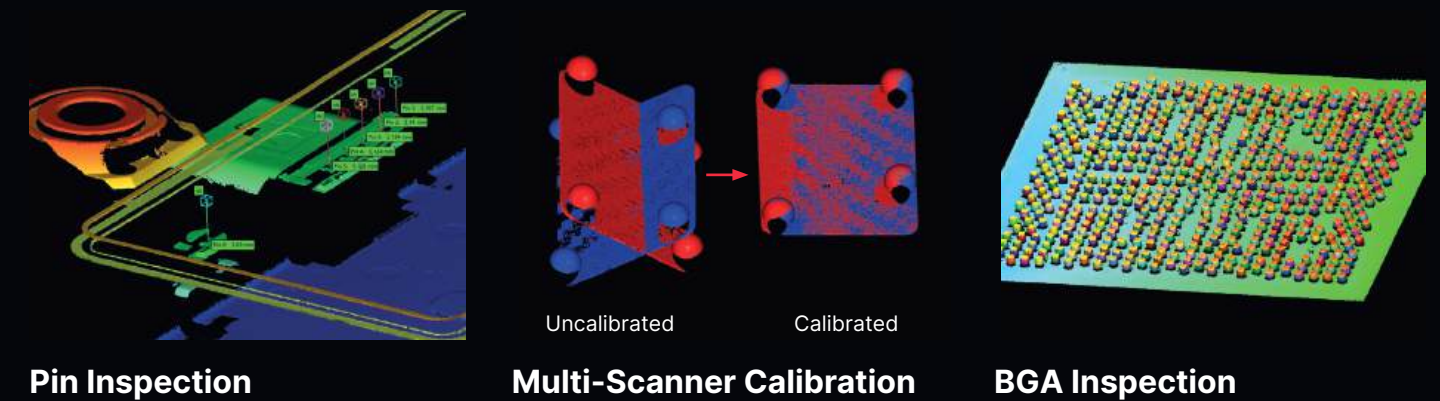

**3D Measurements in Under 10 Minutes!**

Fast + Easy  
3D Software

- 1 Install AT SolutionPackage
- 2 Scan object
- 3 Visualize measurement data
- 4 Design evaluation



# Improve your Multi-Scanner Calibration

- ✓ Four models depending on field of view
- ✓ Easy multi-scanner calibration
- ✓ Improved measurement quality
- ✓ Correction of linear transportation error

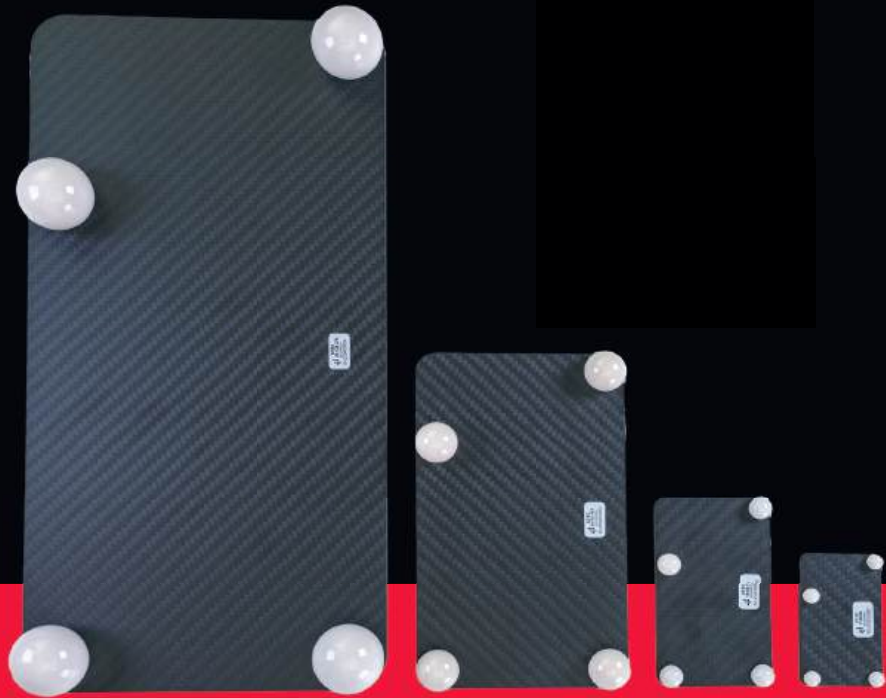

## MetrologyPackage

Create your 3D processing prototype within 10 minutes

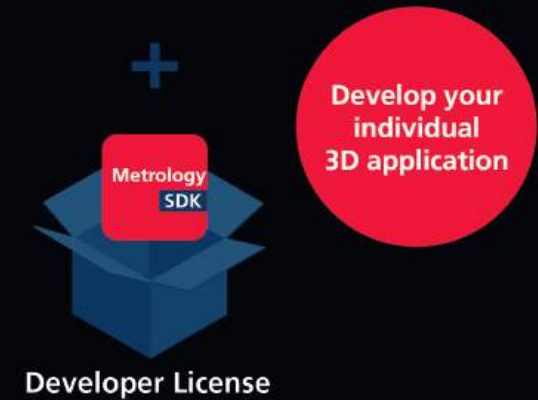

## Develop your Customer-Specific Application

## 3D METROLOGY SOLUTION

PREVIOUS

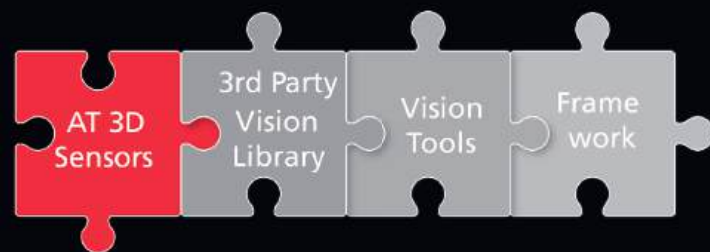

Usual way to your individual solution

NOW

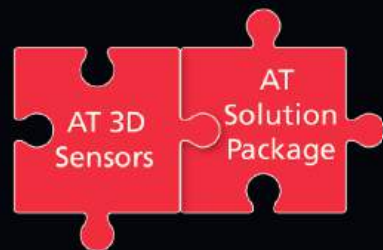

Easy way to your individual solution

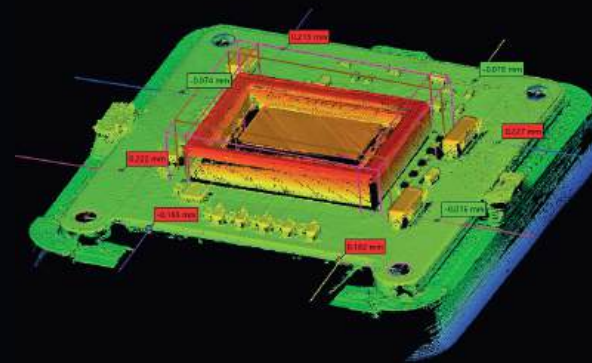

### Your Benefits Using the Developer License

- ✓ Build your own complete software solution
- ✓ Use this software solution for your own measurement tasks
- ✓ Integrate your measurement task into your application
- ✓ Optimized for metrology applications

Individual Design for Every Measurement Task



"The ultimate 3D Metrology Solution is like a 'puzzle' and we have all parts now!"

André Kasper, AT CTO





**Contact us for more  
information**

**info@1stvision.com**

**www.1stvision.com**

1stVision, Inc.

40 Shattuck Road, Suite 227

Andover, MA 01810

Office 978-474-0044

Fax 978-268-5743