

FXO 10GigE

fxo531CXGE



Preliminary product information. Features and technical specifications are subject to change without notice.

General

Model:	fxo531CXGE
Product code:	F002446
Product series:	FXO 10GigE
Status:	Prototype/engineering sample

Sensor

Sensor type:	Area scan
Chroma:	Mono
Spectrum:	Visible
Spectral range:	400 nm to 1000 nm
Resolution:	4,512 × 4,512 (20.40 MP)
Sensor model:	Sony IMX531
Sensor architecture (material):	cmos
Shutter type(s):	global-shutter
Sensor size:	12.36 × 12.36 mm (17.48 mm, 17.5mm (Type 1.1))
Pixel size:	2.74 μm × 2.74 μm

Pixel formats

Sensor bit depth:	8-Bit,12-Bit
Monochrome pixel formats:	mono8, mono12

Timing and gain

Max. frame rate:	58.8 fps
Exposure time:	5 μ s to 60 s
Gain:	0.0 dB to 48.0 dB

I/Os and power

Non-isolated lines:	0 x LVDS input, 0 x LVDS output, 0 x TTL input, 0 x TTL output, 2 x 24V input, 4 x Open drain output,
Specific non-isolated lines:	1 x RS232 input, 1 x RS232 output, 0 x RS422 input, 0 x RS422 output,
Opto-isolated lines:	1 x Optical isolated input, 0 x Optical isolated input,
Power supply:	10 to 25VDC
Power consumption:	External: 12 W (typical)

Operating conditions

Operating temperature (housing):	-10 °C to 60 °C
----------------------------------	-----------------

Mechanical properties

Body dimensions (L x W x H in mm):	76 x 50 x 50
Filter/protection glass:	K9 - AR coating - 400-850nm
IP class:	IP30
Lens mount(s):	C-Mount
Weight:	240 g

On-board memory and FPGA

Image buffer (RAM):	896 MByte
Non-volatile memory (Flash):	32 MByte

Interfaces

Digital interface:	10gige
Interface connector:	(RJ-45)

FW features - image control

Exposure modes:	Manual, Auto, External
Gain modes:	Auto, Manual
Image control features:	FW Features - Image Control

FW features - camera control

Trigger modes/sync:	INTERNAL,SOFTWARE,EXTERNAL
---------------------	----------------------------

FW features - camera control

Camera control features:

PTP, RDMA support, User Sets, PWM(4), Sequencer,

preliminary

Color

(not included: lens- and light source characteristics)

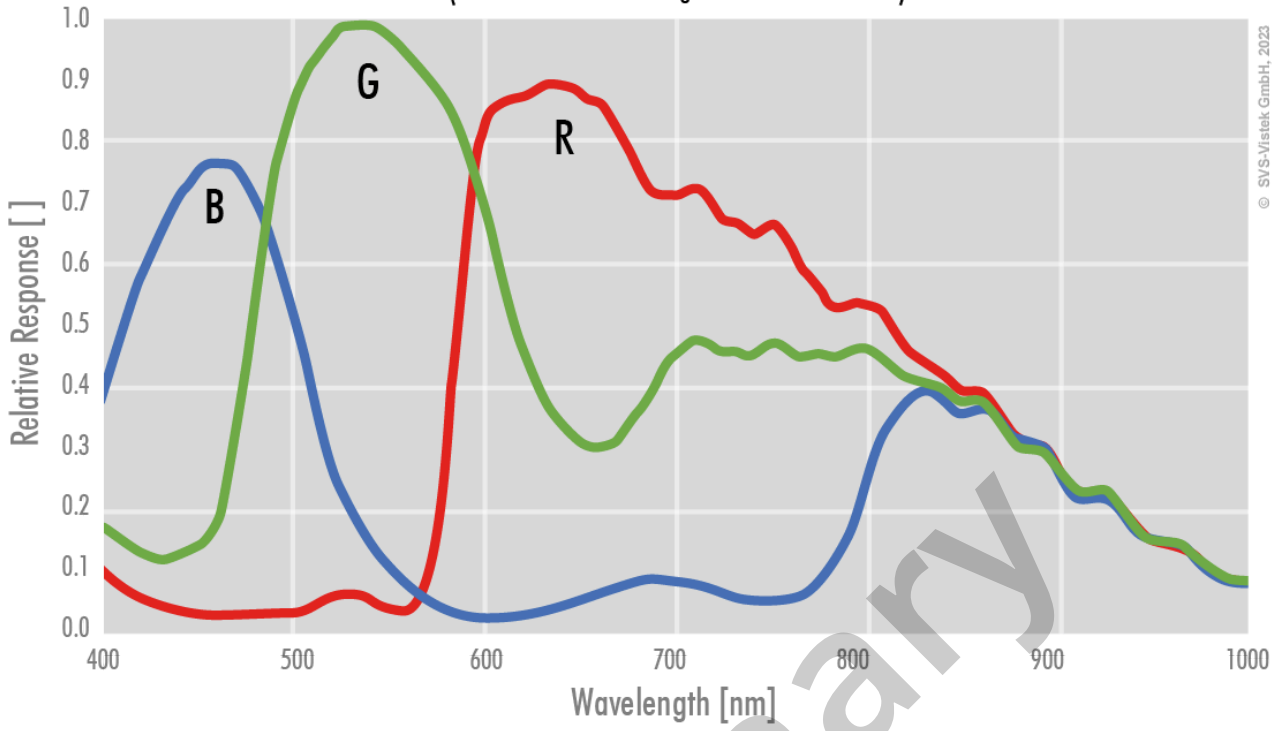

preliminary

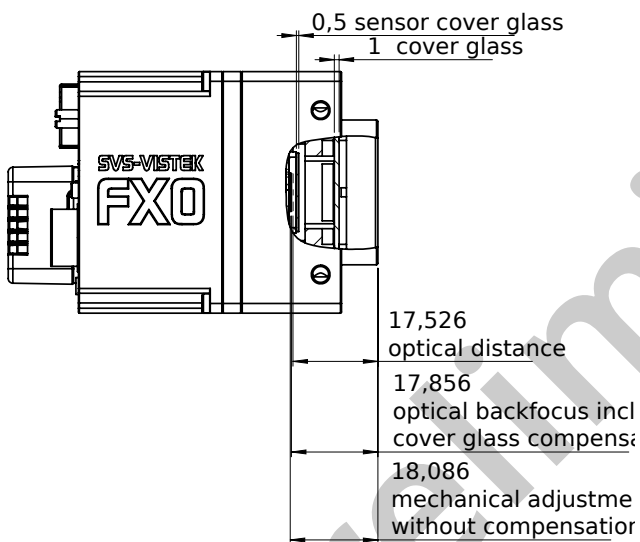
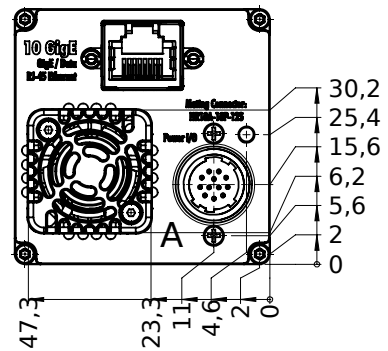
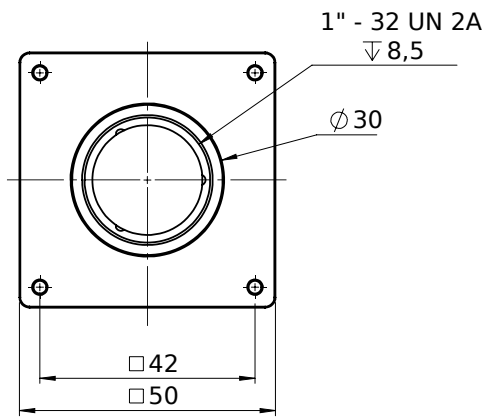

M4 - 6H $\nabla 5$
 same from left

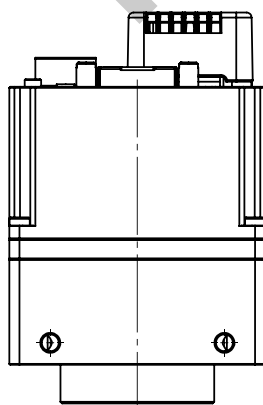
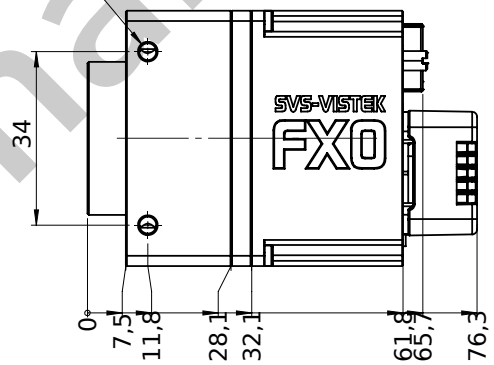

1/4 - 20 UNC
 $\nabla 5,0$

M4 - 6H $\nabla 5$
 same from top

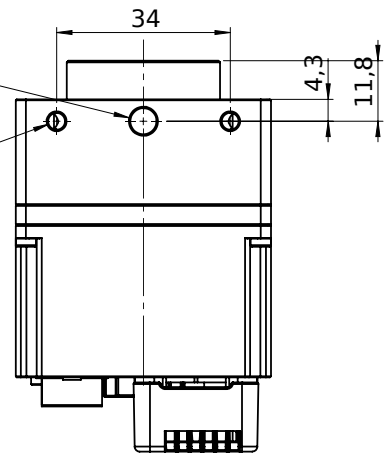

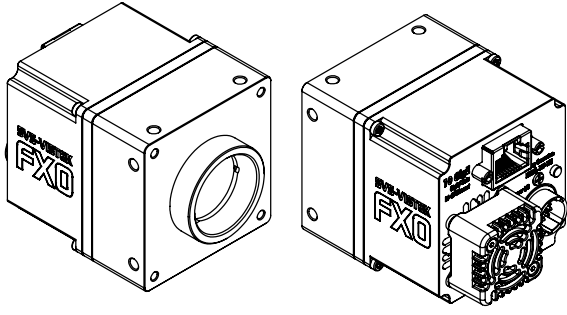

I/O pin assignment

Hirose 12 Pin



1	VIN -	(GND)	7	OUT 1	(open drain)
2	VIN +	(10 V to 25 V DC)	8	OUT 2	(open drain)
3	IN 4	(RXD RS232)	9	IN 3 +	(opto In +)
4	OUT 4	(TXD RS232)	10	IN 3 -	(opto In -)
5	IN 1	(0-24V)	11	OUT 3	(open drain)
6	IN 2	(0-24V)	12	OUT 0	(open drain)

preliminary