

- Versatile temperature range for extreme environments
- CMOSIS CMOS sensor
- PTP and PoE
- P-Iris and DC-Iris lens control

Description

2 Megapixel CMOS camera for extreme environments - GigE Vision®

Prosilica GT2000 is a 2 Megapixel camera with a Gigabit Ethernet interface (GigE Vision®). GT2000 incorporates a high-quality CMOSIS CMV2000 CMOS sensor. GT2000 is a rugged camera designed to operate in extreme environments and fluctuating lighting conditions. GT2000 offers Precise iris lens control allowing users to fix the aperture size to optimize depth of field, exposure and gain without the need for additional control elements.

Options:

- Various IR cut/pass filters and lens mounts

Specifications

Prosilica GT	2000
Interface	IEEE 802.3 1000BASE-T, IEEE 802.3af (PoE)
Resolution	2048 × 1088
Sensor	CMOSIS CMV2000
Sensor type	CMOS Progressive
Sensor size	Type 2/3
Cell size	5.5 μm
Lens mount	C (adjustable)
Max frame rate at full resolution	53.7 fps
ADC	12 bit
On-board FIFO	128
Output	
Bit depth	8/12 bit
Mono modes	Mono8, Mono12, Mono12Packed
Color modes YUV	YUV411Packed, YUV422Packed, YUV444Packed

Prosilica GT	2000
Color modes RGB	RGB8Packed, BGR8Packed, RGBA8Packed, BGRA8Packed
Raw modes	BayerGB8, BayerGB12, BayerGB12Packed
General purpose inputs/outputs (GPIOs)	
TTL I/Os	1
Opto-isolated I/Os	1 input, 2 outputs
RS-232	1
Operating conditions/dimensions	
Operating temperature	-20°C ... +65°C
Power requirements (DC)	PoE, or 7-25 VDC
Power consumption (@12 V)	4.2 W (PoE) / 3.4 W @ 12 VDC
Mass	210 g
Body dimensions (L × W × H in mm)	86 × 53.3 × 33 mm including connectors, w/o tripod and lens
Regulations	CE, FCC Class A, RoHS (2011/65/EU)

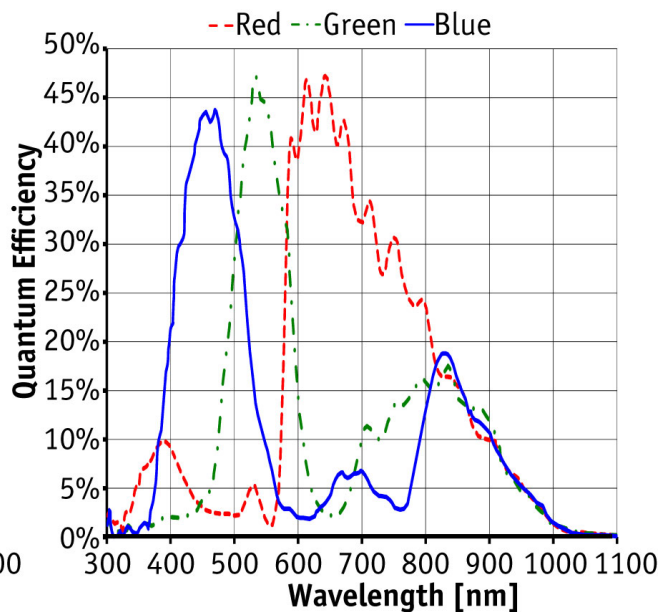
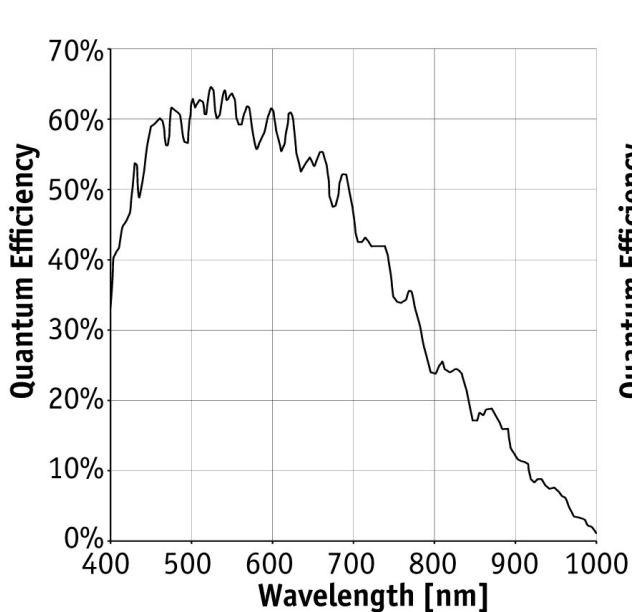

Features

Prosilica GT2000 features include:

- Precision Time Protocol (IEEE 1588)
- Camera temperature monitoring
- Defect masking



- Auto iris (P-Iris and DC-Iris)
- ROI, separate ROI for auto features
- Auto gain (manual gain control: 0 to 26 dB)
- Auto exposure (manual exposure control: 18 μ s to 126.2 s)
- Auto white balance
- Gamma
- Hue, saturation, color correction
- StreamBytesPerSecond (easy bandwidth control)
- Stream hold
- Sync out modes: Trigger ready, input, exposing, readout, imaging, strobe, GPO
- Event channel
- Chunk data
- Storable user sets

Technical drawing

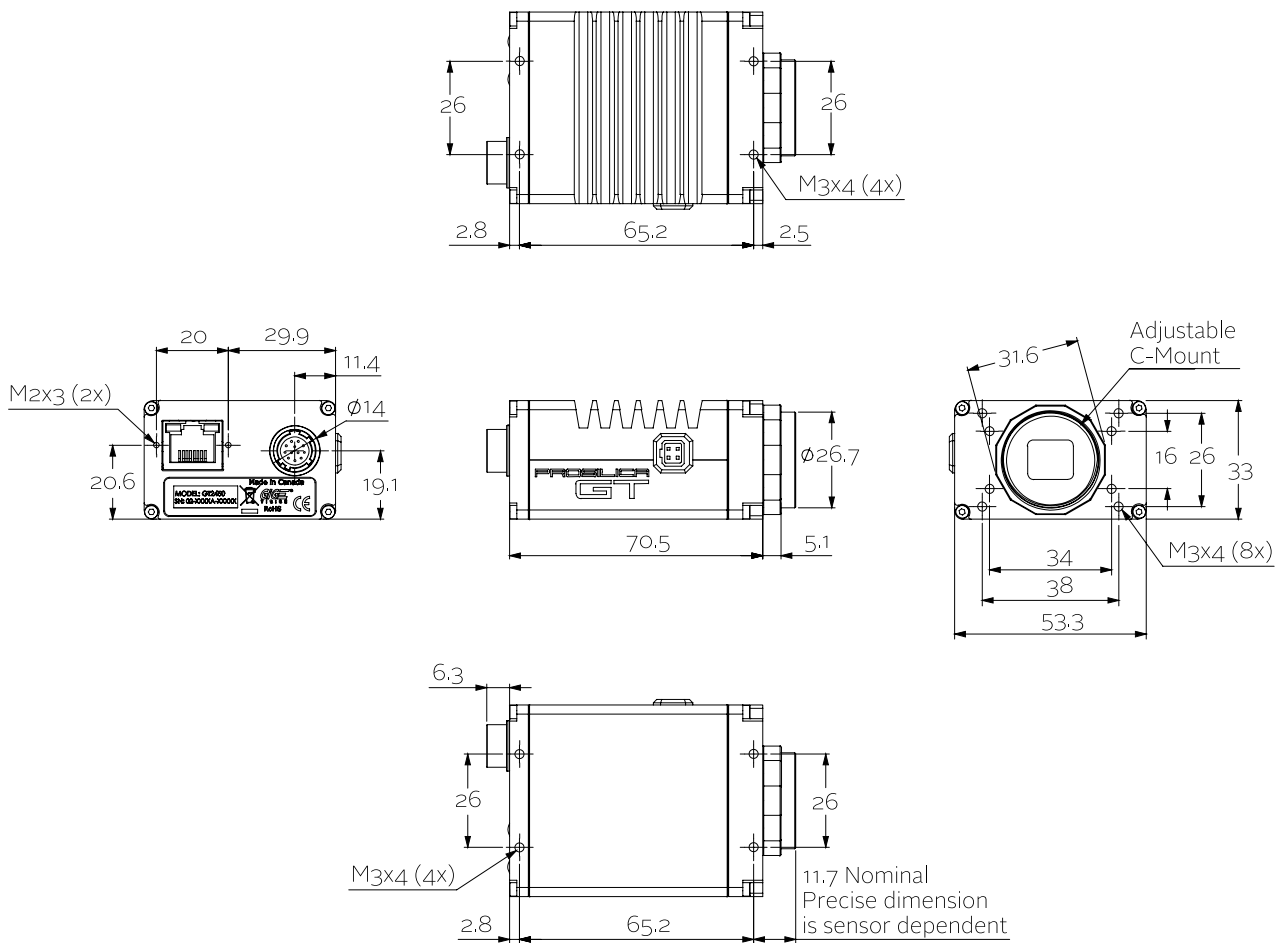

Applications

Prosilica GT2000 is ideal for a wide range of applications including:



- Outdoor imaging
- Traffic imaging / ITS
- Public security and surveillance
- Industrial inspection
- Machine vision
- Military and space applications