

AVT Marlin F-145B2 / F-145C2



Your entrance into the world of digital cameras.

The AVT MARLIN F-145B2 (b/w) and AVT MARLIN F-145C2 (color) are very compact, space saving IEEE 1394 SXGA C-Mount cameras, equipped with a highly sensitive SONY type 1/2 progressive CCD sensor. The camera offers an external asynchronous trigger shutter and operates in 8-bit or 10-bit mode. At full image resolution, the AVT MARLIN F-145B2/C2 offers up to 10 fps and is thus particularly suited for use in industrial image processing and product automation.

The extensive built-in image processing possibilities (image pre-processing) result in outstanding image quality, reduced retouching, less load on the system and higher performance overall. The integrated smart functions take over essential functions of the frame grabber, which is compensated by use of the MARLIN.

The MARLIN can be easily integrated into existing applications thanks to its powerful and flexible API.

Highlights

- SXGA 1392 x 1040 progressive CCD
- Up to 10 fps
- True partial scan (higher frame rates by smaller AOI)
- Format_7 support (flexible AOI, flexible speed)
- Optocoupled asynchronous image trigger
- Binning (F-145B2)
- Image pre-processing features:
 - Auto controlled gain, exposure, white balance
 - Color correction, hue, saturation
 - Real-time shading correction
 - Programmable LUT
 - And lots more ...
- Smart frame grabber features:
 - Image FIFO memory (3 frames)
 - Image mirror
 - Single-shot, multi-shot, free-run
 - 2 programmable inputs
 - 2 programmable outputs
 - And lots more ...
- B/w and color
- Very good image quality, natural color response
- Super compact size
- C-Mount, CS-Mount
- Angled head and customized housings

AVT Marlin F-145B2 / F-145C2

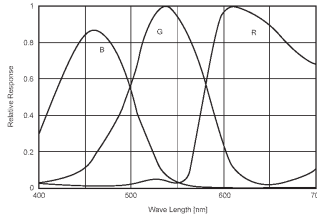
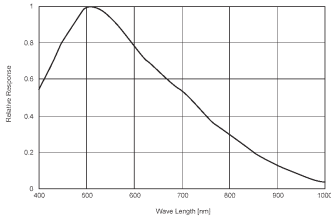

Sensor specifications b/w; color (extracted from the data sheet of the sensor - excluding lens and filter)

AOI height / pixel	Frame rate / fps
1040	10.3
960	11.0
768	13.0
600	15.5
480	17.9
240	26.1
120	33.5
60	39.3

Format_7 Raw8/Mono8

Pin	Descriptions	Use
1	Ground	
2	Power In (CCD only)	GND for RS232 and ext. power
3		
4	Input1/Trigger	TTL, Edge, progr.
5		
6	Output 1 /IntEna	Open emitter
7	Input Ground	
8	RS232 RxD	common ground for inputs
9	RS232 TxD	
10	OutVCC	
11	Input 2	Common VCC for outputs
12	Output 2	Open emitter



Connections

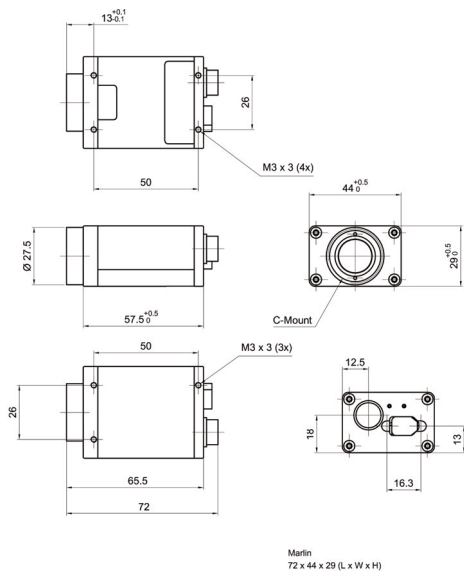

Dimensions

Camera Specifications

	MARLIN F-145B2 (b/w)	MARLIN F-145C2 (color)
Image device	Type 1/2 (diag. 8 mm) progressive scan SONY CCD	
Effective picture elements	1392 (H) x 1040 (V): mono	1392 (H) x 1040 (V) @ Raw8 1392 (H) x 1036 (V) @ YUV, RGB
Picture size	1280 x 960 pixels (Format_2); supporting all smaller fixed formats; up to 1392 x 1040 pixels (Format_7 Mode_1)	
Cell size	4.65 µm x 4.65 µm	
Resolution depth	8 bit / 10 bit (b/w only); 12 bit (ADC)	
Lens mount	C-Mount	
Digital interface	IEEE 1394 IIDC v. 1.3	
Transfer rate	100 Mbit/s, 200 Mbit/s, 400 Mbit/s	
Frame rates	Up to 10 Hz in Format_7; 7 Hz (RGB8)	
Gain control	Manual: 0-24 dB (0.0345 dB/step); auto gain (select. AOI)	
Shutter speed	20...67.108.864 µs (67 s); auto shutter (select. AOI)	
External trigger shutter	Trigger_Mode_0, Trigger_Mode_1, advanced feature: Trigger_Mode_15 (bulk); image transfer by command; trigger delay	
Smart features	Real-time shading correction; image sequencing; built in FIFO memory up to 3 frames; one user programmable look-up table; 2 configurable inputs, 2 configurable outputs; image mirror (L-R<->R-L), binning, secure image signature (SIS), user profiles, serial port (IIDC V1.3)	
Power requirements	DC 8 V – 36 V via IEEE 1394 cable or 12-pin HIROSE	
Power consumption	Less than 3 watt (@ 12 V DC)	
Dimensions	72 mm x 44 mm x 29 mm (L x W x H); w/o tripod and lens	
Mass	<120 g (without lens)	
Operating temperature	+5 ...+ 45 °Celsius	
Storage temperature	-10...+ 60 °Celsius	
Regulations	EN 55022, EN 61000, EN 55024, FCC Class B; DIN ISO 9022, RoHs (2002/95/EC)	
Options	Removable IR cut filter; host adapter card, locking IEEE 1394 cable, AVT FirePackage / Direct FirePackage / Fire4Linux	