



Goldeye

CL-033 TECless

- Fastest Camera Link InGaAs SWIR camera
- VGA resolution
- TECless
- Compact industrial design, no fan
- Simple camera configuration via GenCP

Description

Goldeye CL-033 TECless - High-speed TECless VGA InGaAs camera

The Goldeye CL-033 TECless high-speed camera is the fastest VGA resolution short wave infrared camera (SWIR) with Camera Link interface. Frame rates up to 301 fps at full resolution enable you to access versatile application fields and to speed up your processes. Thanks to its very affordable price, many cost-sensitive applications can benefit from the camera's outstanding performance.

Save time and money to integrate the camera into your system: A small form factor and multiple mounting options let the camera fit easily into compact system designs. In addition, its standardized Camera Link interface with GenCP support and comprehensive I/O control options simplify the connection to your software solution and the synchronization with other system components. Several on-board image correction features contribute to the Goldeye's outstanding image quality. Reveal more of the invisible with Goldeye SWIR cameras!

Benefits and features

- Compact industrial design
- Up to 301 fps at full resolution
- Simple camera configuration via GenCP
- Comprehensive I/O control options
- Automated on-board image correction

Options

- Available with C-Mount; F-Mount and M42-Mount available on request

Specifications

Goldeye	CL-033 TECless
Interface	Camera Link Base
Resolution	640 (H) × 512 (V)
Spectral range	900 nm to 1700 nm
Sensor	InGaAs FPA 640 × 512
Sensor type	InGaAs
Sensor size	No standard size
Pixel size	15 μm × 15 μm
Cooling temperature	(n/a)
Temporal dark noise	390 e ⁻ (Gain0), 32 e ⁻ (Gain2)
Dark current	430 ke ⁻ /s (@ +45 °C FPA temperature)
Saturation capacity	1.2 Me ⁻ (Gain0), 25 ke ⁻ (Gain2)
Dynamic range	69 dB (Gain0), 59 dB (Gain2)
Lens mount (default)	C-Mount, F-Mount, M42-Mount
Max. frame rate at full resolution	301 fps
ADC	14 bit
Image buffer (RAM)	256 MByte
Output	
Bit depth	8 - 14 bit
Monochrome pixel formats	Mono8, Mono12, Mono12Packed, Mono14
General purpose inputs/outputs (GPIOs)	
TTL I/Os	LVTTL I/Os: 1 input, 1 output
Opto-isolated I/Os	1 Input, 2 Outputs
RS232	115 200 Baud, 8N1 (adjustable)
Operating conditions/dimensions	
Operating temperature	-20 °C to +55 °C (Case)
Power requirements (DC)	10.8 V DC to 30.0 V
Power consumption	6.0 W (@ 12 VDC)
Mass	320 g (with C-Mount adaptor)
Body dimensions (L × W × H in mm)	78 × 55 × 55
Regulations	CE: 2014/30/EU (EMC), 2011/65/EU (RoHS); FCC Class B

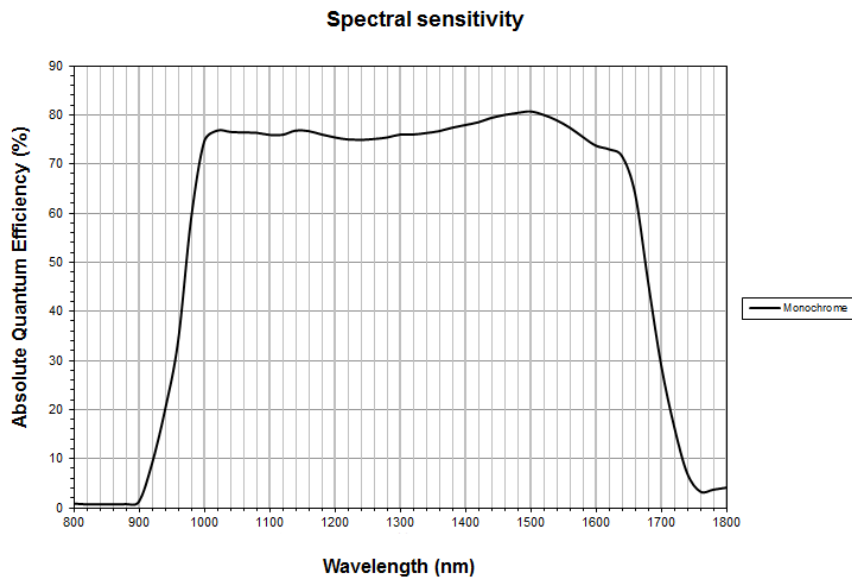

Features

IR-specific features (camera and sensor)

- Integrierte Korrekturdatensätze, Kompensation von Sensor-Inhomogenität und Untergrundstrukturen (Non-Uniformity Correction - NUC)
- Defect Pixel Korrektur
- Hintergrund Subtraktion
- Sensortemperaturmanagement manuell oder automatisch via TEC Features
- Temperaturstatus-Anzeige
- Temperaturspezifische Events

General features

- Automatische Belichtungszeitsteuerung
- Gain (analog)
- I/O Konfiguration und Trigger Kontrolle
- Verzögerte Bildausgabe (Stream Hold)
- Speicherbare Anwenderkonfigurationen (User Sets)
- Firmware- Update im Feld
- Region of Interest (ROI) Einstellung, Look-Up Table (LUT) Unterstützung, sowie diverse Auto-Features
- Einstellbare Pixeltakt-Frequenz
- Unterstützung der Camera-Control-Signale (CC-Ports)
- Automatischer Beginn der Bildaufnahme nach dem Kamerastart



Goldeye Kameras sind kompatibel mit Allied Vision's Vimba SDK, das Ihnen die Anbindung der Kamera an Ihre Anwendung vereinfacht.

Darüber hinaus stehen Ihnen durch unsere AcquireControl Software weitere Bildanalysefunktionen zur Verfügung, wie beispielsweise:

- Pseudo Color LUT mit verschiedenen Farbprofilen
- Automatische Kontrast- und Helligkeitssteuerung
- Analyse von mehreren Bildausschnitten (rechteckig, kreisförmig, usw.)
- Echtzeit-Statistik und Histogramm-Anzeige

Technical drawing

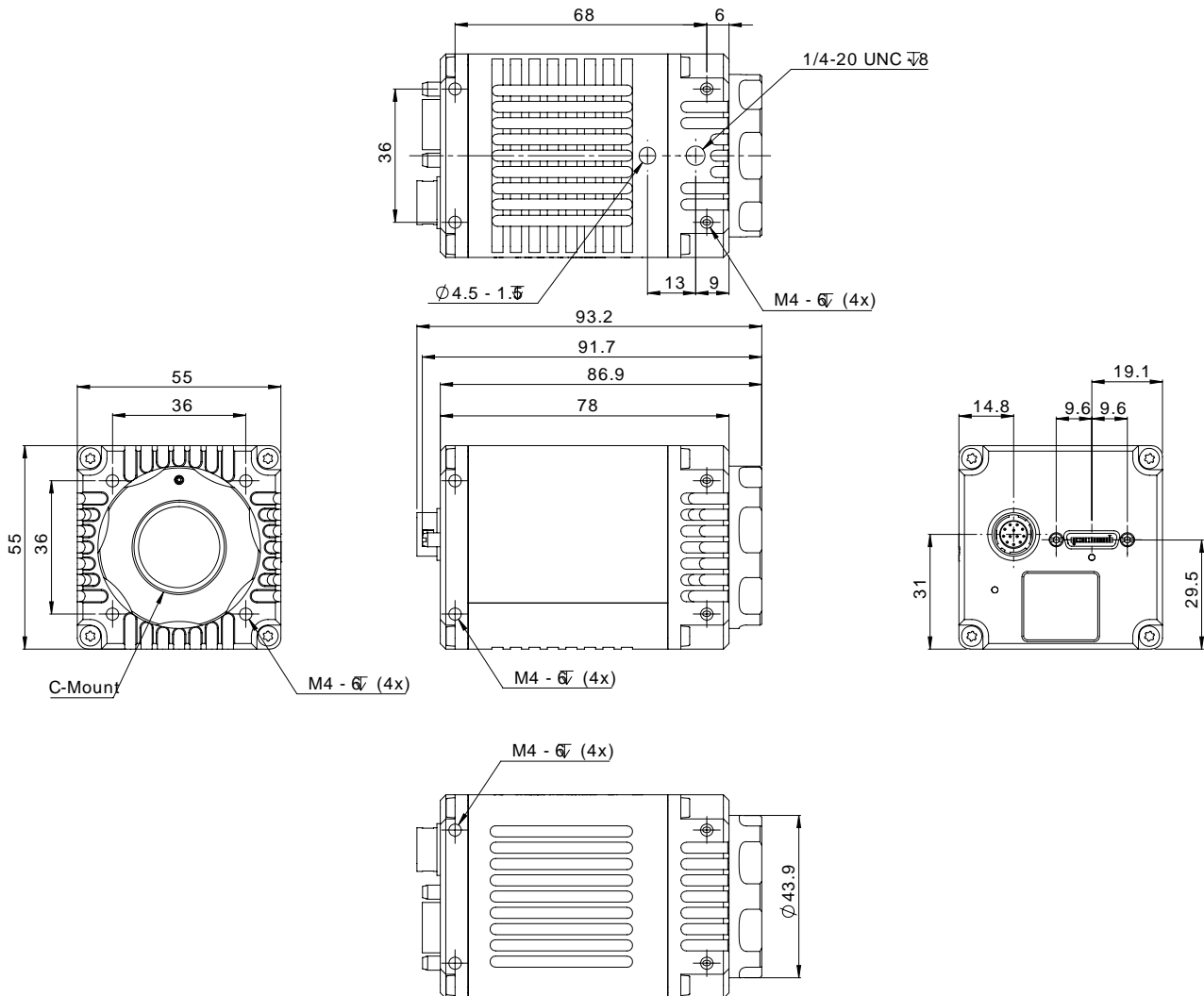



Applications

Goldeye cameras are very sensitive in the SWIR spectrum. They can be used in an extended operating temperature range. Thanks to integrated image correction, Goldeye cameras achieve an outstanding image quality with little noise and a high dynamic range. They are well-suited for many typical SWIR applications in various industry branches:

- Semiconductor industry: solar cell and chip inspection
- Recycling industry: plastics sorting
- Medical imaging, sciences: hyperspectral imaging, microscopy, OCT
- Metal and glass industry: thermal imaging of hot objects (250 °C to 800 °C)
- Agriculture industry: airborne remote sensing
- Printing industry: banknote inspection
- Electronics industry: laser beam profiling
- Surveillance and security: vision enhancement (e.g., through fog or night vision)

White Paper

To learn more about typical application fields for SWIR cameras, download our White Paper:

[Seeing beyond the visible – short-wave infrared \(SWIR\) cameras offer new application fields in machine vision](#)