



Bonito PRO

X-1250

- Latest CMOS sensor
- CXP-6 speed
- PoCXP
- 142.6 fps at full resolution

Description

12.5 Megapixel CMOS camera for wide temperature ranges - CoaXPress

The Bonito PRO is Allied Vision's brand new high-bandwidth camera series with a CoaXPress interface. Equipped with four DIN 1.0/2.3 connectors the camera is capable to transmit 25 Gbps via quad CXP-6 (6.25Gbps) high-speed connections. The Bonito PRO features a rugged, fan-less housing design and its powerful feature set make this camera an ideal choice for high-definition imaging applications demanding high-throughput, robustness, and system design-in flexibility. By default, monochrome and NIR models ship with no optical filter and color models ship with an IRC30 IR cut filter.

Benefits and features:

- Monochrome (X-1250B), color (X-1250C), and extended near-infrared (X-1250B NIR) models
- Extended feature set with Sequencer Control and Multiple Region of Interest selection to support advanced imaging applications
- On-board Defect Pixel and 2D Fixed Pattern Noise Correction for improved image quality
- Simplified firmware update in the field via interface cables using GenICam File Access
- Robust, fan-less design for industrial imaging applications
- Heat-dissipation optimized housing to reduce image noise
- Build-in tripod adapter and multiple mounting holes for eased system integration
- DIN 1.0/2.3 CoaXPress connectors for secure operation in industrial environments
- Single cable solution using Trigger and Power over CoaXPress (PoCXP)
- Comprehensive I/O functionality for extended control of connected system components

Options:

- Multiple mount options for flexible lens selection: F-Mount, FF-Mount, M42-Mount, M58-Mount. All with or without planarity pre-adjustment (PA mount option).



- Available with IR cut filter or protection glass

See the [Modular Concept](#) for lens mount and optical filters options. See the [Customization and OEM Solutions](#) webpage for additional options.

Specifications

Bonito PRO	X-1250
Interface	CoaXPress (CXP-6) 4 DIN
Resolution	4096 (H) × 3072 (V)
Sensor	ON Semi PYTHON 12K
Sensor type	CMOS
Sensor size	Type 4/3
Pixel size	4.5 μm × 4.5 μm
Lens mount (default)	F-Mount
Max. frame rate at full resolution	142.6 fps
ADC	10 bit
Non-volatile memory (Flash)	1024 KB
Output	
Bit depth	10 bit
Monochrome pixel formats	Mono8, Mono10
Raw pixel formats	BayerRG8, BayerRG10
General purpose inputs/outputs (GPIOs)	
TTL I/Os	1 input, 2 outputs
Opto-isolated I/Os	1 input, 2 outputs
Operating conditions/dimensions	
Operating temperature	-20 °C to +70 °C housing (without condensation)
Power requirements (DC)	24 VDC; PoCXP
Power consumption	~15.7 W at 24 VDC; ~15.7 W PoCXP
Mass	~500 g (depending on lens mount type)
Body dimensions (L × W × H in mm)	114.9 × 70 × 70 (with F-Mount and connectors)
Regulations	CE: 2014/30/EU (EMC), 2011/65/EU, including amendment 2015/863/EU (RoHS); FCC Class B; CAN ICES-003 Issue 6

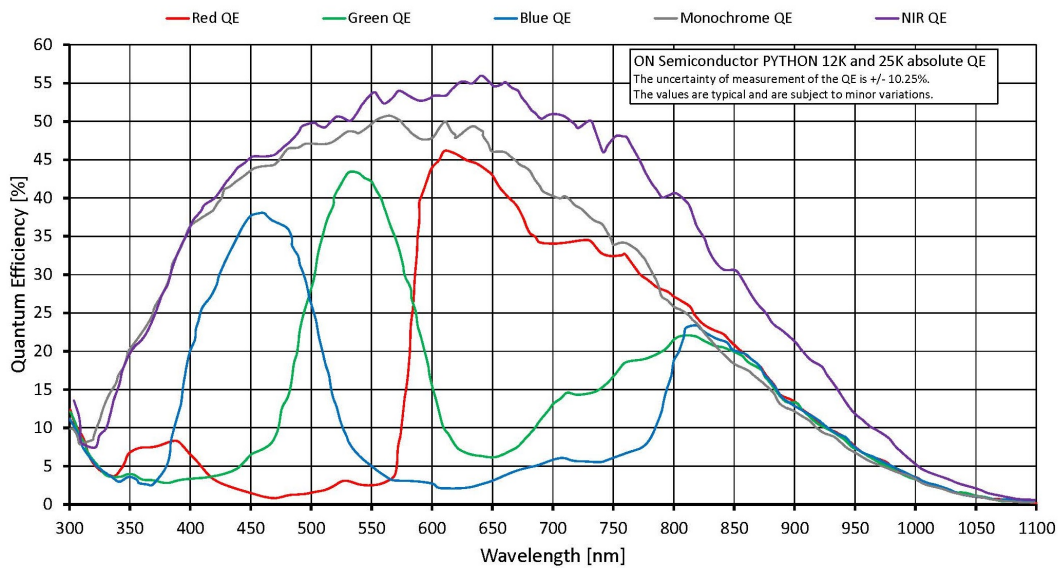

Features

Image optimization features:

- Auto gain (manual gain control: 0 to 22 dB)
- Auto exposure (manual exposure control: 1 μ s to 1 s)
- Auto white balance (X-1250C only)
- Binning (horizontal and/or vertical), (sum or average)
- Decimation X/Y
- Gamma correction
- Three look-up tables (LUTs)
- Defect Pixel Correction
- Fixed Pattern Noise Correction

Camera control features:

- Multiple region of interest (Multi-ROI)
- Sequencer Control
- Trigger over CoaXPress
- EF lens control (order option -18)
- Storable user sets
- Sync out modes: Trigger ready, input, exposing, readout, imaging, strobe, GPO
- Temperature monitoring (main board and sensor board)

Technical drawing

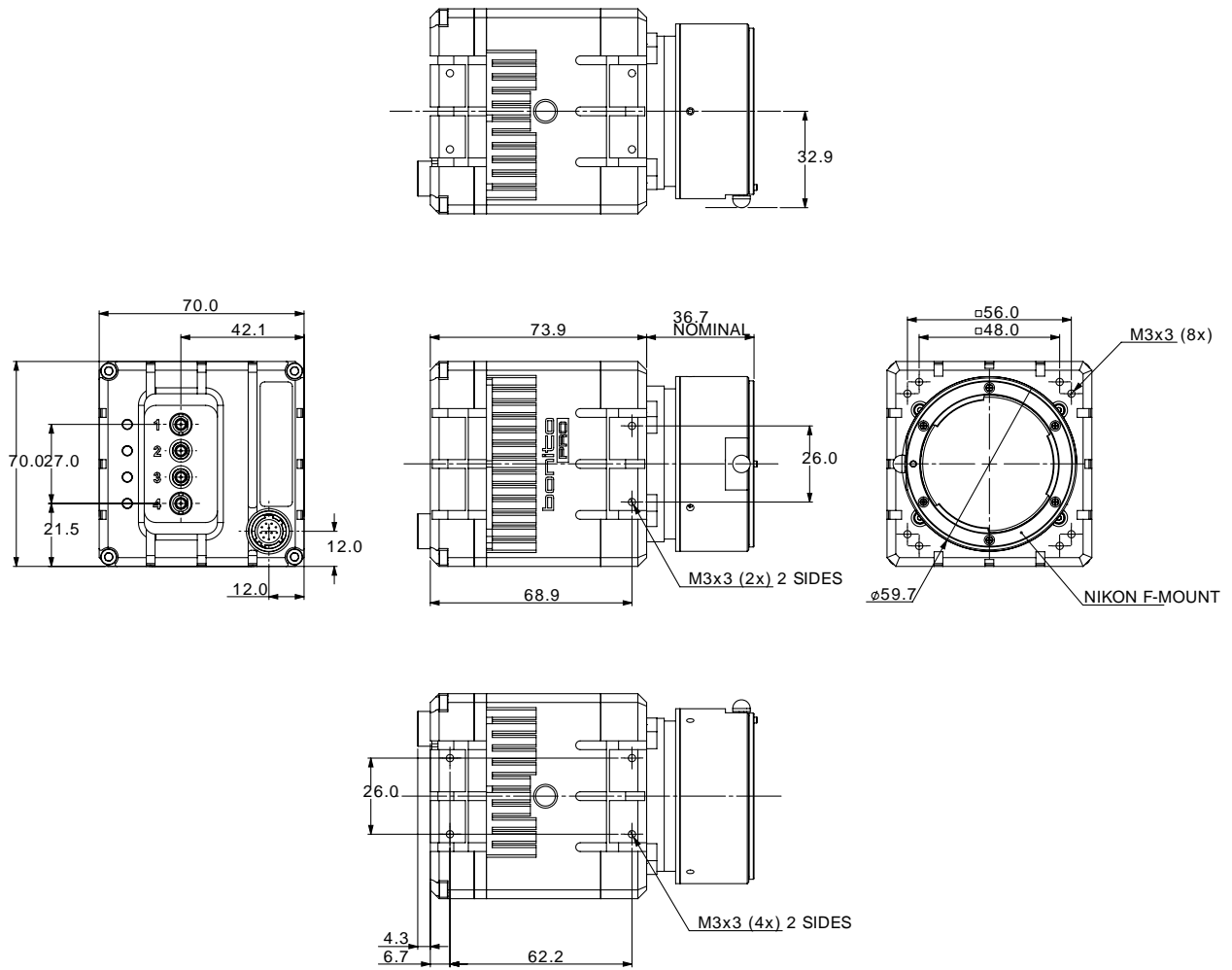



Applications

Bonito PRO X-1250 is ideal for a wide range of applications including:

- Automated Optical Inspection of flat panel displays, PCB/electronics, printings
- 2D/3D Surface Inspection (for example, glass)
- Aerial imaging