

BI-TELECENTRIC LENS FOR 2/3" TO 1/4" DETECTORS

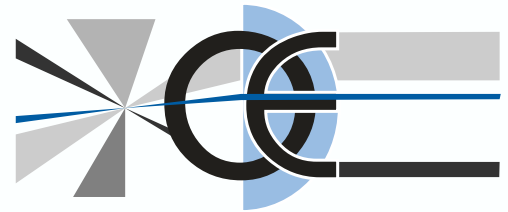

WWW.OPTO-ENGINEERING.COM



| | | |
|--|-----------------------|---------------|
| Model: | TC 23 24 | |
| Magnification (X): | 0,37 | |
| Object Field (mm): | 1/4" (3,6 x 2,7): | 9,82 x 7,36 |
| | 1/3" (4,8 x 3,6): | 13,09 x 9,82 |
| | 1/2" (6,4 x 4,8): | 17,45 x 13,09 |
| | 1/1.8" (7,13 x 5,37): | 19,44 x 14,64 |
| | 2/3" (8,8 x 6,6): | 24,00 x 18,00 |
| Working Distance (mm): | 63,4 +/- 2 | |
| Working F-number: | 8 | |
| MTF @70 lp/mm (%): | >45 | |
| Field Depth (mm): | 7,0 @ F/ 8 | |
| Image side N.A.: | 0,062 | |
| Object side N.A.: | 0,022 | |
| Telecentricity (degree): | < 0,1 | |
| Distortion (%): | < 0,1 | |
| Mount: | C | |
| Length (mm): | 142 | |
| Maximum external diameter (mm): | 44 | |
| Weigh (g): | 290 | |

NOTES:

- 1) The inner aperture diaphragm can be supplied on request with smaller apertures in order to achieve a larger Field Depth
- 2) Tailored diffusive Ring Light available on request
- 3) Custom flanges and mechanical interfaces can be provided on request
- 4) Can be coupled to a collimated light illuminator like LT CL 24

| Rev No. | Description | Date | Name |
|---------|-------------|----------|-----------|
| A | First light | 01/05/03 | A.Vismara |
| D | Redesign | 18/07/06 | A.Vismara |

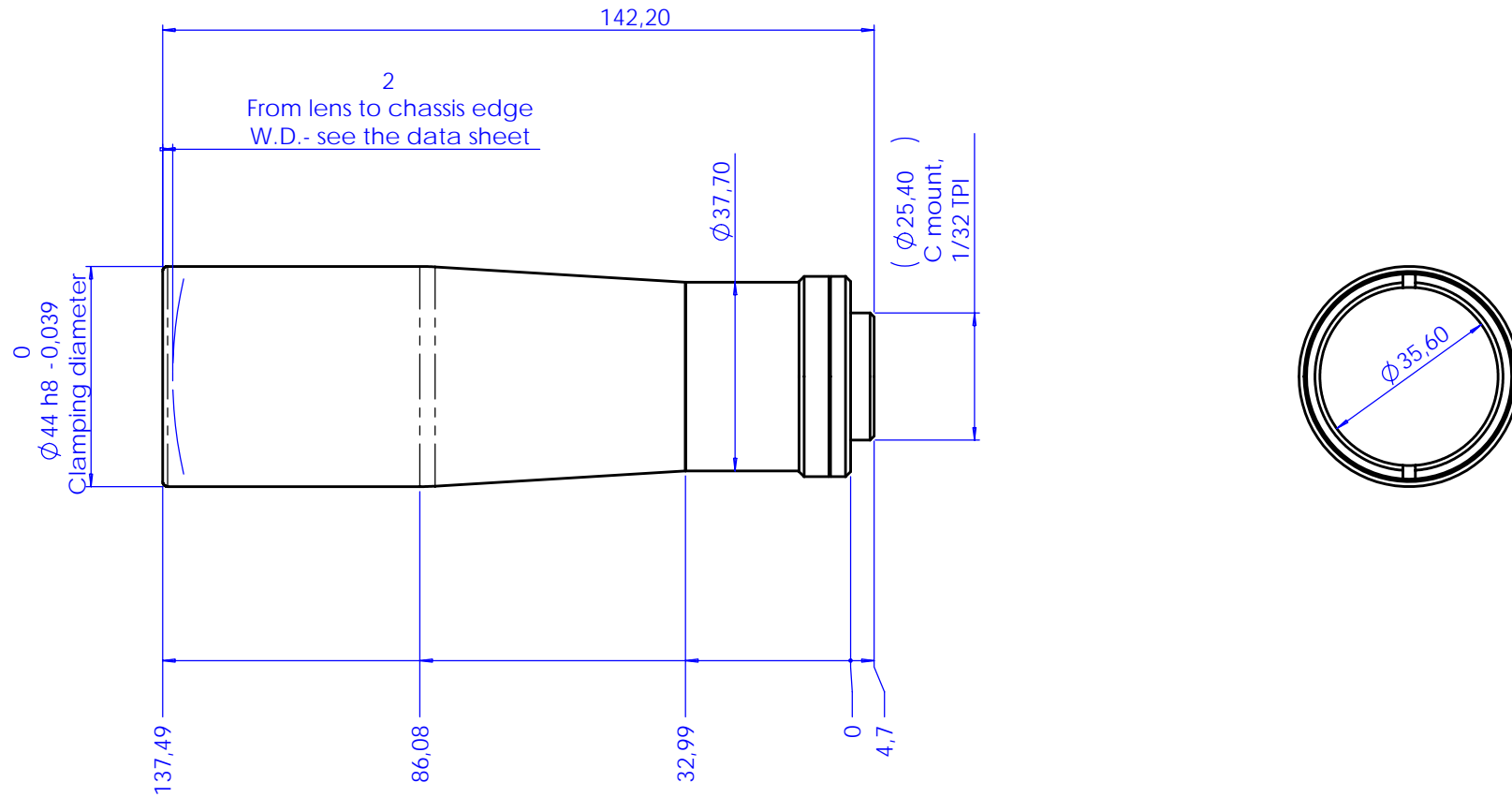

| | | | | | | | |
|------------------------------------|------|------|---|--|----------------------|-------------|-------|
| Material | N.A. | | | Mass | 0.41 kg | Scale | 1:1 |
| Surface treatment | N.A. | | | Project-Prod.Item/Instrument Telecentric lens 23 24 | | | |
| Geometrical tolerance (ISO 2768-2) | | | Class | K | Undimensioned bevels | Description | |
| Linear tolerance (ISO 2768-2) | | | Class | m | 1x45° | Assembly | |
| 0.5 | >3- | >6- | >30- | >120 | >400- | >1000 | >2000 |
| +3 | 6 | 30 | 120 | +400 | +1000 | +2000 | +4000 |
| ±0.1 | ±0.1 | ±0.2 | ±0.3 | ±0.5 | ±0.8 | ±1.2 | ±2 |
| | | | | | Undimensioned radii | R 0.5 | |
| | | | Date | | Name | | |
| | | | Designed | 18/07/06 | A.Vismara | | |
| | | | Draw | 18/07/06 | A.Vismara | | |
| | | | Checked | X | C. Sedazzari | | |
| | | | Drawing No. | | Sheet | | |
| | | | 01501-0-D | | 1/1 | | |
| | | | Reproduction forbidden without specific authorization | | | | |