

# BI-TELECENTRIC LENS FOR 1/3" TO 1/4" DETECTORS



WWW.OPTO-ENGINEERING.COM



<b>Model:</b>	<b>TC 13 64</b>		
<b>Magnification (X):</b>	0,08		
<b>Object Field (mm):</b>	1/4" (3,6 x 2,7):	48,0	x 36,0
	1/3" (4,8 x 3,6):	64,0	x 48,0
	1/2" (6,4 x 4,8):	∅	= 64,0
	1/1.8" (7,13 x 5,37):	∅	= 71,6
	2/3" (8,8 x 6,6):	n.a	
<b>Working Distance (mm):</b>	182,3 +/- 5		
<b>Working F-number:</b>	8		
<b>MTF @70 lp/mm (%):</b>	> 40		
<b>Field Depth (mm):</b>	130,0 @ F/ 8		
<b>Image side N.A.:</b>	0,062		
<b>Object side N.A.:</b>	0,004		
<b>Telecentricity (degree):</b>	<0,08		
<b>Distortion (%):</b>	<0,07		
<b>Mount:</b>	C		
<b>Length (mm):</b>	212		
<b>Maximum external diameter (mm):</b>	100		
<b>Weigh (g):</b>	930		

## NOTES:

- 1) The inner aperture diaphragm can be supplied on request with smaller apertures in order to achieve a larger Field Depth
- 2) Tailored diffusive Ring Light available on request
- 3) Custom flanges and mechanical interfaces can be provided on request
- 4) Can be coupled to a collimated light illuminator like LT CL 64
- 5) compatible with Diffuse Coaxial LT CX 64 Illuminator

Rev No.	Description	Date	Name
A	First light	01/05/03	A.Vismara
D	Redesign	24/03/06	A.Vismara

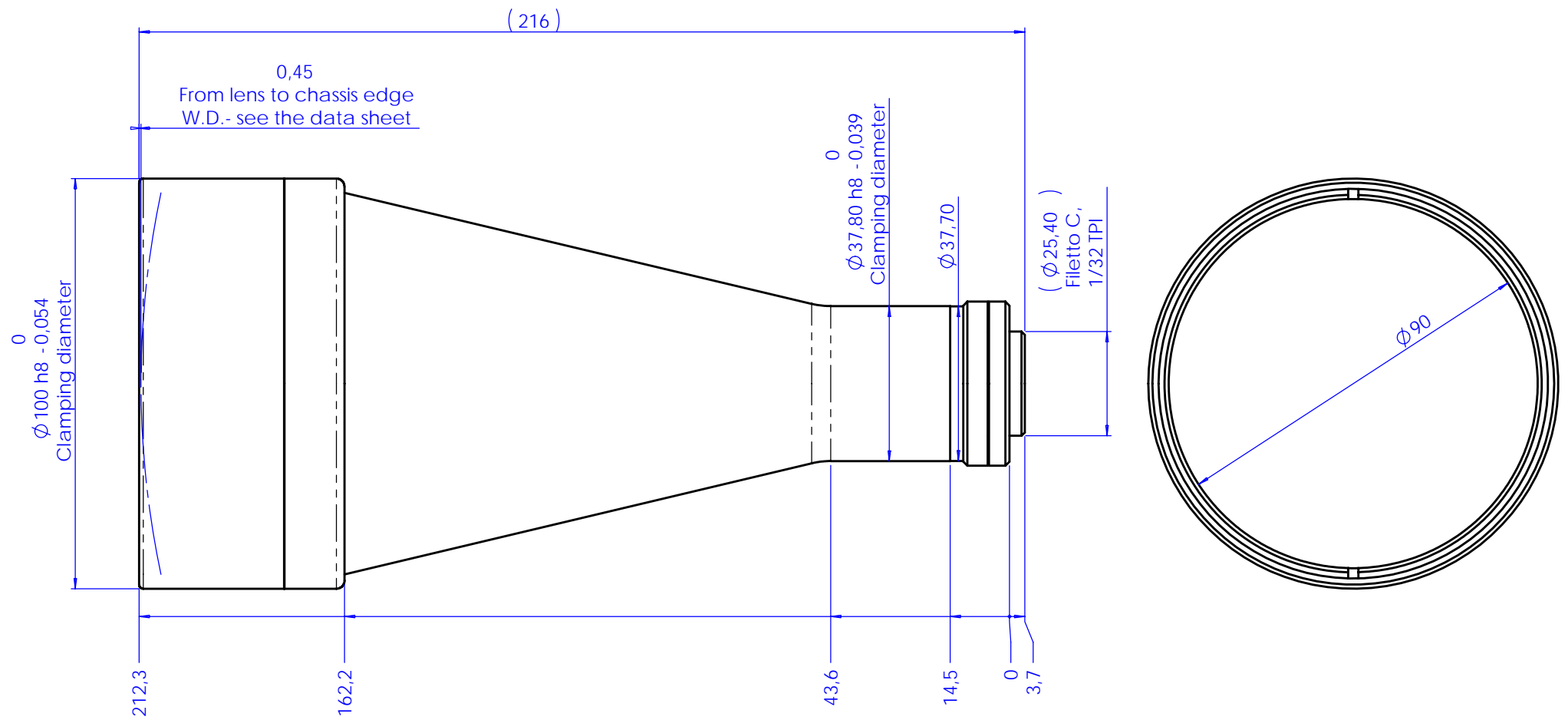

Material	N.A.			Mass	1.0 kg	Scale	1:1
Surface treatment	N.A.			Project-Prod.Item/Instrument Telecentric lens 13 64			
Geometrical tolerance (ISO 2768-2)			Class	K	Description		
Linear tolerance (ISO 2768-2)			Class	m	Undimensioned bevels	1x45°	Assembly
0.5	>3-	>6-	>30-	>120	>400-	>1000	
+3	6	30	120	+400	+1000	+2000	R 0.5
±0.1	±0.1	±0.2	±0.3	±0.5	±0.8	±1.2	±2
			Date	Name		Drawing No.	
www.opto-engineering.com			Designed	15/02/06	A.Vismara	01051-0-D	
			Draw	24/03/06	A.Vismara	Sheet	
			Checked	X	C. Sedazzari	1/1	
<i>Reproduction forbidden without specific authorization</i>							

