

BI-TELECENTRIC LENS FOR 1/2" (1/1.8") TO 1/4" DETECTORS

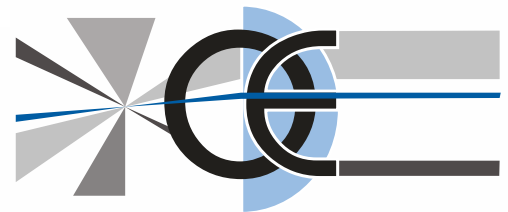

WWW.OPTO-ENGINEERING.COM



Model:	TC 12 36		
Magnification (X):	0,18		
Object Field (mm):	1/4" (3,6 x 2,7):	20,25	x 15,19
	1/3" (4,8 x 3,6):	27,00	x 20,25
	1/2" (6,4 x 4,8):	36,00	x 27,00
	1/1.8" (7,13 x 5,37):	40,10	x 30,20 (5)
	2/3" (8,8 x 6,6):	Ø = 37,13	
Working Distance (mm):	103,5 +/- 3		
Working F-number:	8		
MTF @70 lp/mm (%):	> 40		
Field Depth (mm):	22,0	@	F/ 8
Image side N.A.:	0,062		
Object side N.A.:	0,011		
Telecentricity (degree):	<0,08		
Distortion (%):	< 0,1		
Mount:	C		
Length (mm):	148		
Maximum external diameter (mm):	61		
Weigh (g):	410		

NOTES:

- 1) The inner aperture diaphragm can be supplied on request with smaller apertures in order to achieve a larger Field Depth
- 2) Tailored diffusive Ring Light available on request
- 3) Custom flanges and mechanical interfaces can be provided on request
- 4) Can be coupled to a collimated light illuminator like LT CL 36
- 5) Small vignetting at the image corners possible
- 6) compatible with Diffuse Coaxial LT CX 36 Illuminator

Rev No.	Description	Date	Name
A	First light	01/05/03	A.Vismara
D	Redesign	15/02/06	A.Vismara

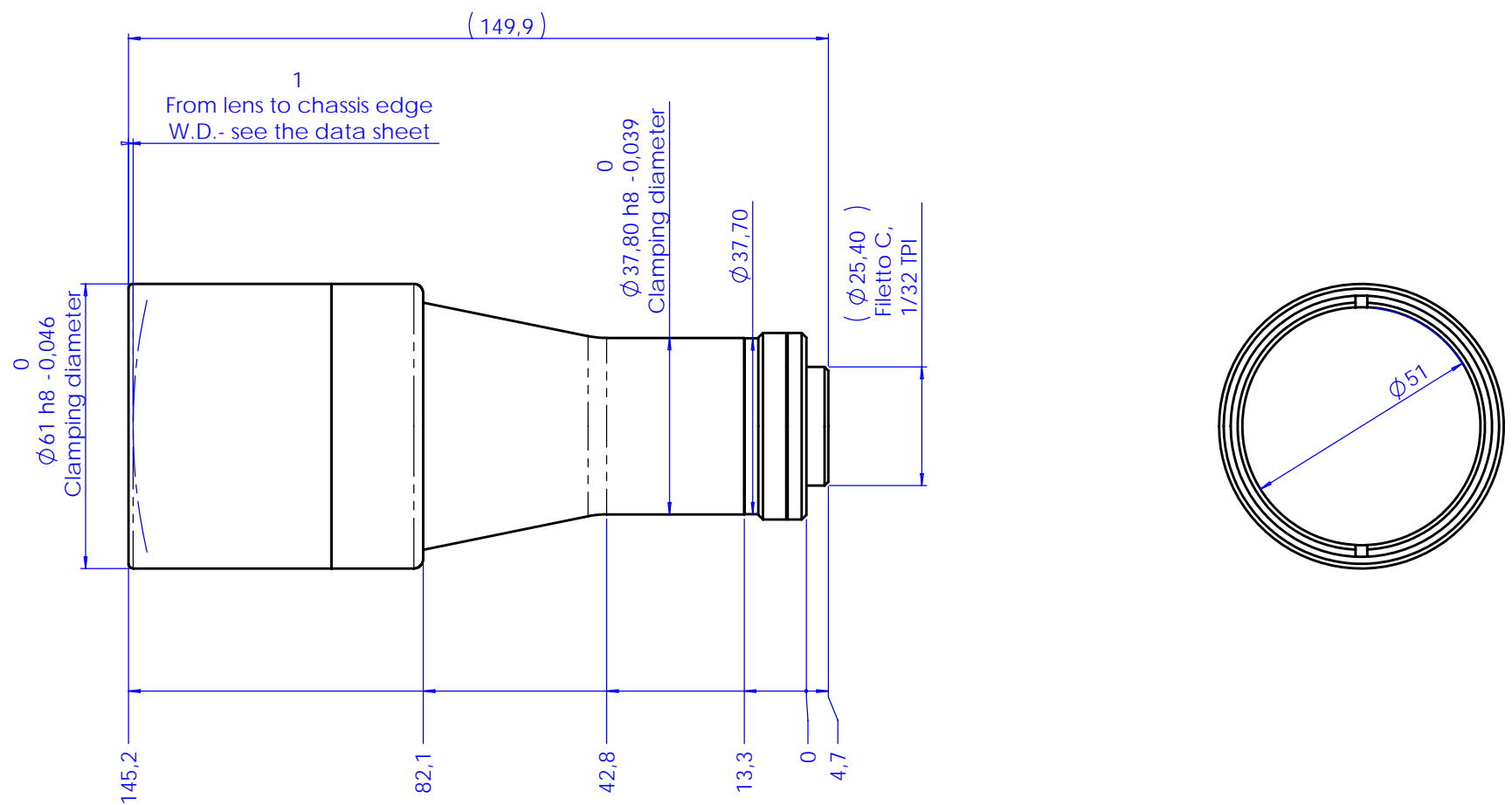

Material	N.A.			Mass	0.48 kg	Scale	1:1
Surface treatment	N.A.			Project-Prod.Item/Instrument Telecentric lens 12 36			
Geometrical tolerance (ISO 2768-2)			Class	K	Undimensioned bevels	1x45°	Description Assembly
Linear tolerance (ISO 2768-2)			Class	m			
0.5	>3-	>6-	>30-	>120	>400-	>1000	>2000
+3	6	30	120	+400	1000	+2000	+4000
±0.1	±0.1	±0.2	±0.3	±0.5	±0.8	±1.2	±2
		Date		Name		Drawing No.	
Designed		15/02/06	A.Vismara		01101-0-D		Sheet
Draw		15/02/06	A.Vismara				1/1
Checked		X	C. Sedazzari		Reproduction forbidden without specific authorization		