

X64-CL™ Full



KEY FEATURES

- Acquires images from one Base, Medium or Full Camera Link camera
- Rapid image acquisition rates up to 680 MB/s and high-speed image transfer to host memory at 528MB/s
- Up to 2GB local frame buffer
- Supports Camera Link operations up to 85MHz

OVERVIEW

Camera Link™ frame grabber for high speed machine vision

Compatible with one Base, Medium or Full Camera Link camera, the X64-CL Full is universal PCI slot compliant and supports all standard multiple tap area and linescan color and monochrome Camera Link cameras. For greater versatility, the X64-CL Full can also interface with custom camera formats, including pixel depths and tap configurations not covered by the Camera Link standard.

The X64-CL Full has been built within Coreco Imaging's Trigger-to-Image Reliability technology framework. Trigger-to-Image Reliability leverages Coreco Imaging's hardware and software innovations to control, monitor and correct the image acquisition process from the time that an external trigger event occurs to the moment the data is sent to the PCI bus. Trigger-to-Image Reliability enables more efficient and reliable machine vision inspections by securing the image acquisition process, providing traceability when errors do occur and permitting recovery from those errors.

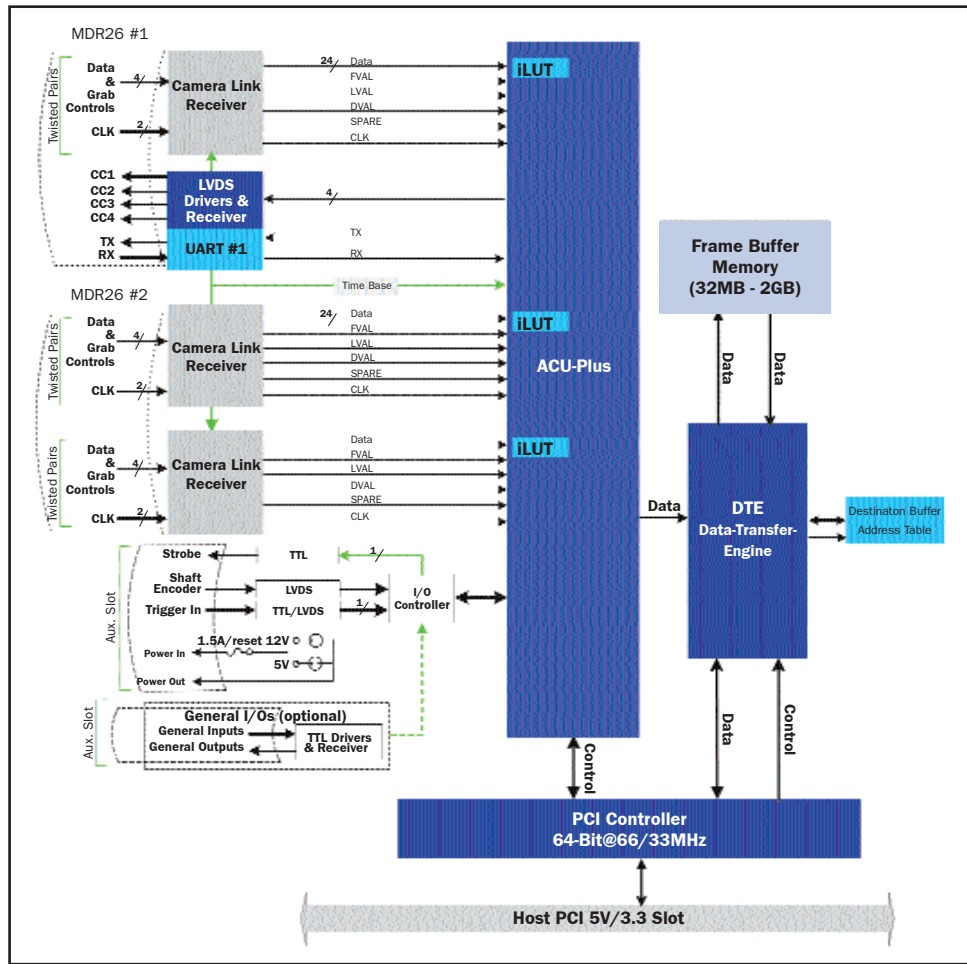

X64-CL Full - Functional Block Diagram

Unprecedented Acquisition Control

Successful industrial machine vision applications require consistent and predictable results in demanding operating environments. The X64-CL Full Acquisition Control Engine (ACU), delivers an unprecedented level of acquisition functionality. The X64-CL Full not only provides the industry's most flexible front-end for interfacing Camera Link cameras, it also incorporates a fault tolerant image synchronization design, allowing it to automatically detect report and recover from a lost camera signal ensuring a greater level of reliability within the imaging sequences.



The X64-CL Full gives machine vision application developers the ability to combine color and monochrome acquisition on a single board. Developers can perform critical pixel transformations during the acquisition process saving valuable preprocessing time.

Embedded timing logic within the ACU identifies each acquired image with a time code, allowing image data to be readily correlated with physical objects on the production line.

Capable of acquiring images at rates up to 255MB/s per channel (510MB total), the X64-CL Full makes image acquisition from the new generation of CMOS and multi-tap CCD camras more efficient and

cost effective. The board supports fixed and variable size frames ranging up to 256KB horizontal pixels per line and up to 16 million vertical lines per frame for area scan cameras. Precise timing controls allow frame size adjustments in steps of 8 pixels/step for horizontal lines and in steps of one line/step vertically.

In conjunction with an onboard quadrature shaft-encoder input, the ACU acquires images from a linescan camera at a rate that is locked to the speed of the web. The X64-CL shaft-encoder feature now supports cascaded divide and multiply to further increase the step resolution. More accurate step resolution results in a higher quality image that makes processing algorithms more accurate and tolerant to motion artifacts. One feature of particular interest to OEMs developing web-scanning applications is the X64-CL's ability to support infinite length frames from a linescan camera, which enables 100 percent line capture as well as repeatable accuracy and faster execution times.

Optimized Data-Transfer

Delivering fast and secure data transfer with zero CPU usage, the X64-CL Full's Data Transfer Engine (DTE) features high speed memory interface, multiple independent Direct Memory Access (DMA), and onboard tap descriptors, the DTE's powerful architecture delivers robust performance for critical machine vision tasks.

The DMAs allow the DTE to transfer images from the acquisition control unit to local frame buffer memory, or transfer the same image to multiple addresses in the host memory. The ACU and DTE use the onboard memory to perform these operations concurrently, yet at different rates, yielding optimal utilization of system bandwidth. Moreover, the X64-CL Full now supports up to 2GB of onboard memory for higher speed frame rate cameras.

Designed to simplify machine vision tasks, the DTE is also responsible for on-the-fly input tap adjustments for directions, pixel overlap and under lap. This enables the DTE to deliver images that are ready for processing while freeing up the host CPU for other image analysis tasks.

Conventional PCI bus transfers utilizing scatter-gather techniques rely on the CPU to load the host frame buffer destination memory addresses during live acquisition, which increases the load on the CPU and slows image-processing tasks. The DTE offloads this task by using a sophisticated control unit to automatically capture and store the destination frame buffer addresses from the host memory. In addition, the control unit performs autonomous and robust image transfers to ensure data integrity during continuous image acquisition in non-real-time operating systems, such as Windows® XP, Windows® 2000 and Windows NT®.

Camera Support

The X64-CL Full is compatible with one Full, one Medium or one Base Camera Link area or linescan mono or RGB camera. In addition, the X64-CL Full provides optional support for non-Camera Link formats and acquisition from two synchronized Base cameras. It further supports custom camera formats such as four 14/16-bit taps and ten 8-bits/tap¹.

Visual Status LED

The X64-CL Full further facilitates ease-of-use by utilizing visual status LEDs, mounted on the card's bracket, to simplify system installation and setup. A status indicator LED provides visual feedback when the correct camera connection is made and when a grab is in progress; a second LED shows when a valid external trigger is detected. These visual indicators allow developers to instantly recognize if cabling has been correctly set up greatly facilitating the diagnostic process.

General Purpose I/Os

The X64-CL Full offers optional opto-coupled input modules for demanding industrial environments. These interrupt-driven, general-purpose input and output controls allow X64-CL Full boards to react to external inputs more rapidly and predictably to increase the quality of acquired images.

External Event Synchronization

The X64-CL Full features a trigger input, along with strobe and exposure control output signals, to synchronize image captures with external events.

RS-232 Communications Ports

The X64-CL Full features an onboard RS-232C serial port that provides integrated support for camera control and setup for machine vision applications. PC-independent in nature, this communication port can be used with off-the-shelf communication utilities such as HyperTerminal to control and configure Camera Link cameras with ease and without requiring additional external cabling.

Software Support

Acquisition, processing and analysis

The X64-CL Full is fully supported by Coreco Imaging's Sapera™ LT software development libraries enabling applications to be developed under Windows NT®, Windows® 2000, and Windows® XP. Sapera LT allows users to develop applications with C language DLLs, C++® classes or Active X® controls for Microsoft® Visual C/C++® 6.0 (or higher) or Visual Basic® 6.0 (or higher) development platforms.

Sapera LT's advanced image acquisition and control functions are an integral part of Coreco Imaging's stringent Trigger-to-Image Reliability technology framework. Sapera LT offers users a single API across Coreco Imaging's current and future hardware platform, to deliver a comprehensive feature set including program portability, versatile camera controls, flexible display functionality and management, and easy to use application development wizards.

Sapera LT (ver. 5.0) comes bundled with Coreco Imaging's advanced CamExpert, a proprietary camera configuration utility specifically designed to leverage the power of Coreco Imaging's image acquisition boards. This Windows-based utility provides an interactive environment within which to create a new, or modify an existing, configuration file for area and linescan applications.

For image processing and analysis Coreco Imaging offers Sapera Processing. Fully integrated with Sapera LT functionality, Sapera Processing is a dynamic Windows-based comprehensive programming library. Hardware independent and designed to simplify vision application development, Sapera Processing is based on a set of high performance C++ classes and uses MMX, SSE (streaming SIMD Extensions), and SSE2 to meet the challenging operational requirements of today's imaging systems. Scalable in design, Sapera Processing offers a comprehensive set of optimized tools, available as a suite or standalone, including image processing, search (pattern matching), OCR, barcode decoding, and blob analysis. Sapera LT and Sapera Processing combine seamlessly to deliver a powerful and easy to use development resource for advanced image acquisition, processing, and analysis.

Specifications*

Board	Half length PCI 2.1 64-bit 66MHz compliant 5V and 3.3V slot compatible
Acquisition	Acquisition rates up to 680MB/s Horizontal Size (min/max): 8 byte/256KB Vertical Size (min/max): Linescan cameras: 1 line to infinity Area scan cameras: 1 line to 16 million/frame variable length frames Onboard frame buffer memory up to 2GB (32MB standard) One 1024 x 1024 or 1024 x 256 input lookup table ² Single slot solution supports 1 Medium, 1 Base or 2 synchronized Base Camera Link cameras Interfaces to digital area scan or linescan color or monochrome cameras Supports standard multi-tap Camera Link configurations: 1 Full camera: 8 x 8-bit 1 Medium camera: 4 x 8-bit, 4 x 10-bit, 4 x 12-bit, 1 x 30-bit/RGB and 1 x 36-bit 1 Base camera: 3 x 8-bit, 2 x 10-bit, 2 x 12-bit, 1 x 14-bit, 1 x 16-bit, and 1 x 24-bit/RGB Alternate multi-tap Camera Link configurations support: 4 x 14-bit, 4 x 16-bit, 1 x 48-bit or 1 x 64-bit
Pixel Formats Transfers	Monochrome 8, 10, 12, 14, 16, or 36-bit/RGB Real-time transfers to system memory: PCI-32 bus: 32 bits @ 33MHz PCI-64 bus: 64 bits @ 66MHz PCI-X bus: 64 bits @ 66MHz On-the-fly tap adjustments for multiple tap area scan and linescan cameras
Controls	Comprehensive event notification includes start/end-of-frame, sequence or N-line events One independent TTL/LVDS trigger input programmable as active high or low (edge or level trigger) One strobe TTL output for area scan and linescan cameras One PC independent RS-232 COM port provides seamless interface to MS Windows applications Quadrature (AB) shaft-encoder inputs for external web synchronization; supports cascaded divide and multiply Up to 12 interrupt driven I/Os ³ permit external event synchronization
Power Output	Power-on-reset fused +12V/+5V DC output at 1.5A
Software	Microsoft Windows NT 4.0, Windows 2000, and Windows XP compliant Full support of the Sopera programming package Compatible with Microsoft Visual Studio 6.0 and .Net (unmanaged code only), Visual Basic 6.0 and Borland C++ Builder 5.5 or higher
System Requirements	PCI-64 or PCI-32 compliant system and 64MB system memory
Dimensions	8.27" (21cm) Length x 4.20" (10.7cm) Height
Temperature	0° C (32° F) to 55° C (131° F) Relative Humidity: up to 95% (non-condensing)
Markings	FCC class B - approved CE class B - approved

* Last updated April 2004

Notes:

1. Please contact Coreco Imaging for more information on these formats
2. For 4 x 8-bit/tap or 4 x 10-bit/tap maximum
3. Optional module requires auxiliary slot

CORECO
iMAGING

EXCELLENCE IN MACHINE VISION

7075 Place Robert-Joncas, Suite 142, St-Laurent, Quebec, Canada H4M 2Z2

Tel: 514.333.1301 US Subsidiary: 978-670-2000 Email: info@corecoimaging.com

visit us online @ www.imaging.com