

Spyder3 CL S3-14 and S3-24

Dual Line Scan Mono CameraLink Cameras



Key Features

- Camera Link configuration
- Broadband responsivity up to 129 DN(nJ/cm²) @ 0dB gain 8 bit
- Dual linescan technology
- High speed (up to 80 megapixels/second throughput)
- Up to 18.5 kHz line rates
- Extended temperature range
- Exposure control

Programmability

- Programmable gain, offset, line rates, trigger mode, test pattern output, and camera diagnostics
- Selectable high or low sensitivity modes
- Horizontal binning, vertical binning as tall pixel mode
- Flat field correction
- Mirroring and forward/reverse control

Typical Applications

- FPD inspection
- Postal sorting
- Industrial metrology
- Print/food/web/material inspection
- Container inspection
- Pick and place

Overview

3x more responsivity, 2x the speed and no impact on noise.

The Spyder3 CL surpasses its predecessor, the Spyder2, with 3x more responsivity and 2x the speed. At its core is dual line scan technology that achieves unprecedented responsivity and throughput rates of 80 megapixels per second, without impacting noise.

The Spyder3 CL features the Camera Link serial interface and is fully programmable, offering precise control over key performance variables such as gain and offset and improved ease of use and setup.

The temperature range performance of the SC-14 and SC-24 models has increased from an operating temperature of 0 °C to 50 °C to an operating temperature of 0 °C to 65 °C.

In addition to its high performance and affordability, Spyder3 CL also incorporates advanced features such as flat field correction and CDS (Correlated Double Sampling).

Specifications

Resolution	1024 / 2048 / 4096 x 2 pixels
Data Rate	40 megapixels per second (1k and 2k) 80 megapixels per second (1k, 2k and 4k)
Max. Line/Frame Rate	68 (1k) / 36 (2k) / 18.5 (4k) kHz
Pixel Size	14 μm (1k and 2k) 10 μm (4k)
Data Format	8, 12 bit
Output	Base Camera Link
Lens Mount	M42, C, F mount (1k and 2k) M58, F mount (4k)
Responsivity	129 DN(nJ/cm ²) @ 0dB (1k and 2k) 8 bit 85 DN(nJ/cm ²) @ 0dB (4k) 8 bit
Dynamic Range	63 dB
Nominal Gain Range	±10 dB
Size	72 x 60 x 60 (1k and 2k) 60 x 72 x 60 (4k)
Mass	< 300 g
Operating Temp	0 °C to 65 °C
Power Supply	+12 V to +15 V
Power Dissipation	< 5 W (1k and 2k) < 7 W (4k)
Regulatory Compliance	CE and RoHS
Control	MDR26 female Camera Link
Data	Shared with control
Power	Hirose 6 HR10 pin male
Example Part Number	S3-14-01K40-00-R

Spyder3 CL S3-14 and S3-24

Dual Line Scan Mono CameraLink Cameras

The Spyder3 Camera Link sports 3x the responsivity at twice the speed of the Spyder2 while maintaining the same dynamic range and adding the Camera Link interface.

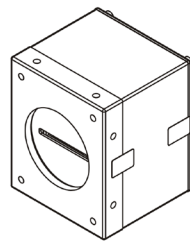
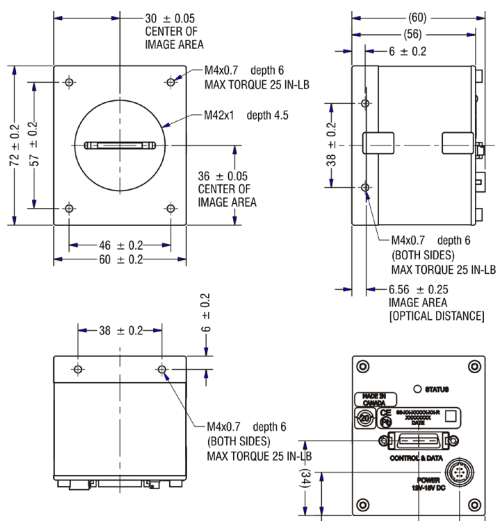
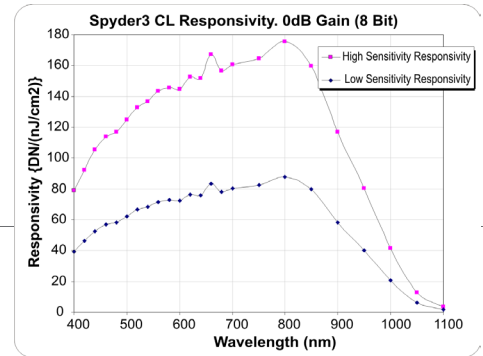

1k and 2k models

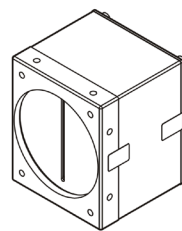
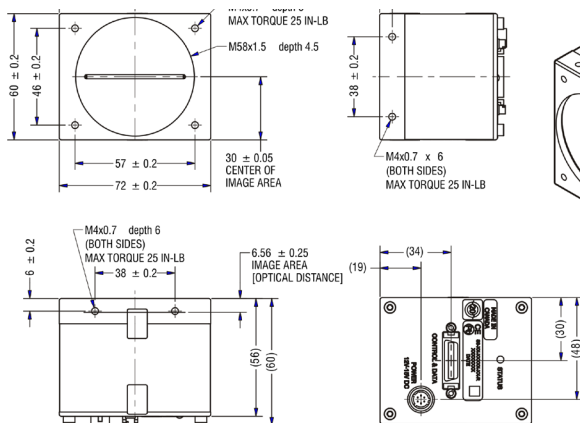

4k model

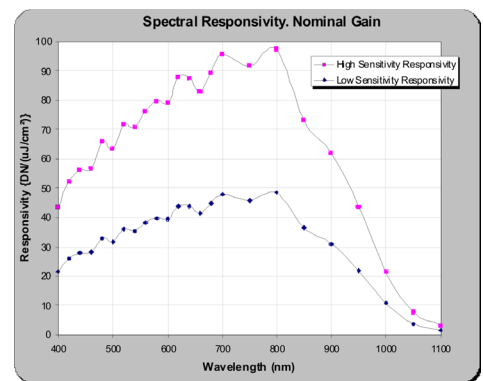

www.teledynedalsa.com

Americas

Boston, USA
+1 978-670-2000
sales.americas@teledynedalsa.com

Europe

Munich, Germany
+49 8142-46770
sales.europe@teledynedalsa.com

Asia Pacific

Tokyo, Japan
+81 3-5960-6353
sales.asia@teledynedalsa.com

Shanghai, China
+86 21-3368-0027
sales.asia@teledynedalsa.com