

PROSILICA

# USER MANUAL

---

August 26, 2008

**GB2450**

**GB2450C**

**GB2450-V**

**GB2450C-V**

Prosilica Inc. [www.prosilica.com](http://www.prosilica.com) tel: 604.875.8855 fax: 604.875.8856

© 2008 Prosilica Inc. All rights reserved.

# Table of Contents

Table of Contents .....	ii
Introduction .....	1
Precautions .....	1
Warranty .....	1
Specifications .....	2
Supported Features .....	3
Mechanical .....	4
Connections .....	7
Cleaning the Sensor .....	11
Adjusting the C-mount .....	12
Camera Installation.....	13
System Optimization .....	18
Trouble Shooting .....	20
Addendum.....	21
GB IO Schematic.....	22
Isolated Trigger Schematic.....	23
Non-isolated Trigger Schematic.....	24
Video Iris Schematic .....	25
Trigger Timing Diagram .....	26
Notes on Triggering.....	27

# Introduction

The GB2450 series of cameras are single board, 5 megapixel, 15 frames per second, Gigabit Ethernet cameras based on the Sony ICX625ALA and ICX625AQA, Super HAD CCD sensors.

## Precautions



### **READ INSTALLATION GUIDE CAREFULLY.**

This document contains specific information which is necessary for the correct operation and treatment of this product.



### **USE ESD PRECAUTIONS WHEN HANDLING PRODUCT.**

This camera contains sensitive components which can be damaged if handled incorrectly.



### **KEEP SHIPPING MATERIAL.**

Poor packaging of this product can cause damage during shipping.



### **VERIFY ALL EXTERNAL CONNECTIONS.**

Verify all external connections in terms of voltage levels, power requirements, voltage polarity, and signal integrity prior to powering this device.



### **CLEANING.**

This product can be damaged by some volatile cleaning agents. Avoid cleaning the image sensor unless absolutely necessary. Please see instructions on sensor cleaning in this document.



### **DO NOT EXCEED ENVIRONMENTAL SPECIFICATIONS.**

See environmental specifications limits in the Specifications section of this document.

## Warranty

Please contact Prosilica.

# Specifications

Sensor Type	Sony ICX625ALA CCD (ICX625AQA for color)
Sensor Shutter Type	Progressive Interline
Image Resolution	2448 x 2050 pixels
Pixel Size	3.45 $\mu$ m x 3.45 $\mu$ m
Optical Format	2/3 inch
Lens Mount	C-mount with adjustable back focus (CS-mount available)
Color Sensor Filter Pattern <sup>†</sup>	Bayer
Full Resolution Frame Rate	15.1 fps
Frame Rate (1900 x 1080 ROI)	24.6 fps
I/O	1 isolated input/output, 1 non-isolated input/output, 1 RS-232 input/output
Power Requirements	Less than 3.8W <sup>††</sup> (5V to 16V) <sup>†††</sup>
Digitization	12 Bits
Trigger latency*	2 $\mu$ s for non-isolated I/O, 10 $\mu$ s for isolated I/O
Trigger Jitter*	$\pm$ 20ns for non-isolated I/O, $\pm$ 0.5 $\mu$ s for isolated I/O
Tpd*	10ns for non-isolated I/O, 1.3 $\mu$ s for isolated I/O
Operating Temperature	0 to 70 Celsius***
Operating Humidity	20 to 80% non-condensing
Weight	60g
Hardware Interface Standard	IEEE 802.3 1000BASE-T, 100BASE-TX
Software Interface Standard	GigE Vision Standard 1.0
Regulatory	RoHS

† Applies to GB2450C only.

†† Power consumption will increase with reduced ROI imaging and color interpolation.

††† Nominal operating voltage is 12V. Cameras have been tested at 12V.

\* See Notes on Triggering in the Addendum.



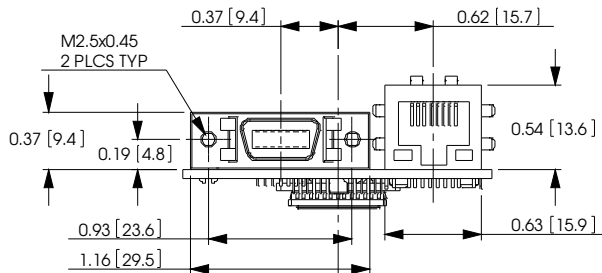
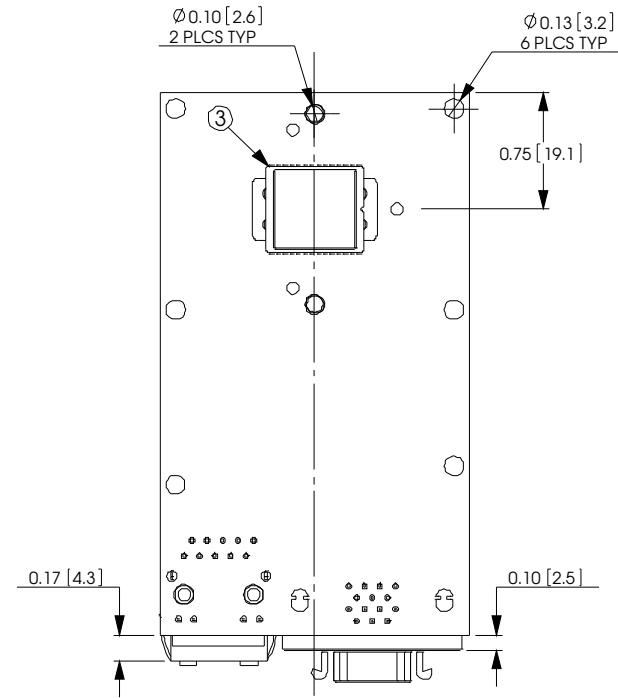
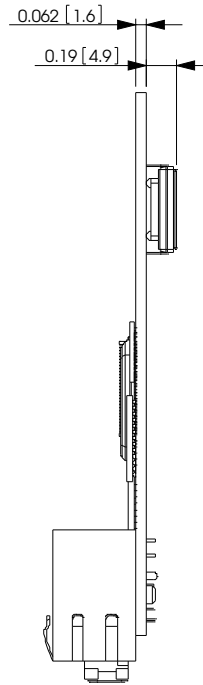
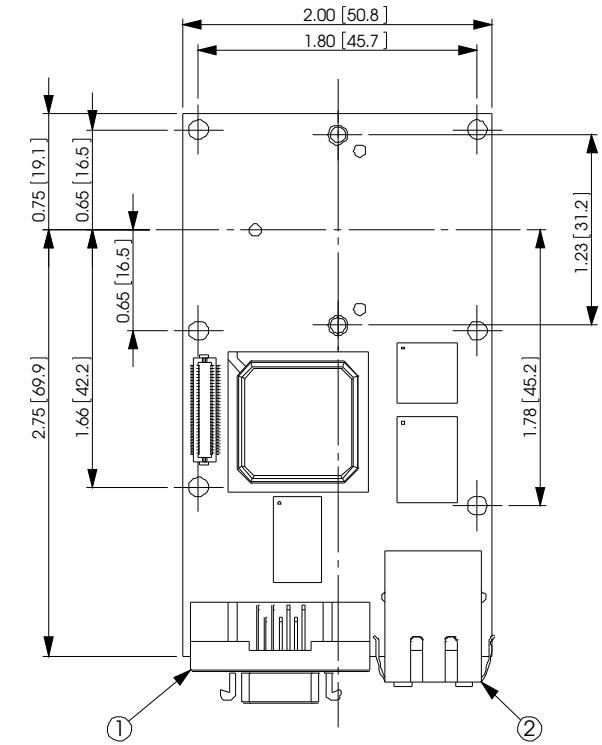
**\*\*\*DUE TO THE SMALL PACKAGING AND HIGH SPEED OF THE GB CAMERAS, SPECIAL CARE IS REQUIRED TO MAINTAIN A REASONABLE OPERATING TEMPERATURE. IF THE CAMERA IS TO BE OPERATED IN A WARM ENVIRONMENT, IT IS SUGGESTED THAT THE CAMERA BE MOUNTED ON A HEAT SINK SUCH AS A METAL BRACKET AND THAT THERE IS SUFFICIENT AIR FLOW.**

## Supported Features

Imaging Modes	free-running, external trigger, fixed rate, software trigger
Fixed Rate Control	0.001 fps to maximum frame rate
External Trigger Delay	0 to 60 seconds in 1 microsecond increments
External Trigger Event	rising edge, falling edge, any edge, level high, level low
Exposure Time	25 microseconds to 60 seconds in 1 microsecond increments
Gain	0 to 24dB
Region of Interest (ROI)	independent x and y control with 1 pixel resolution
Horizontal Binning	1 to 8 pixels
Vertical Binning	1 to 14 rows
Pixel Formats	Mono8, Mono16*, Bayer8, Bayer 16
Sync Out Modes	trigger ready, trigger input, exposing, readout, imaging, strobe, GPO

\*On monochrome versions only.

# Mechanical

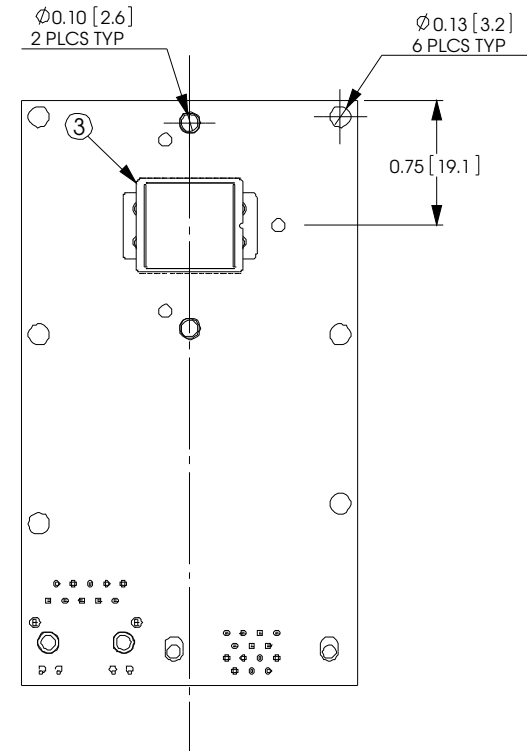
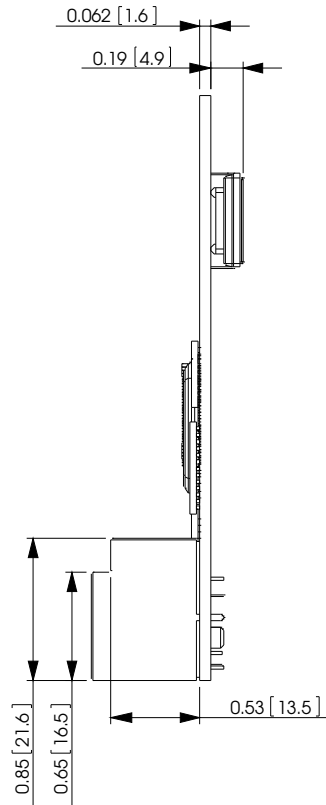
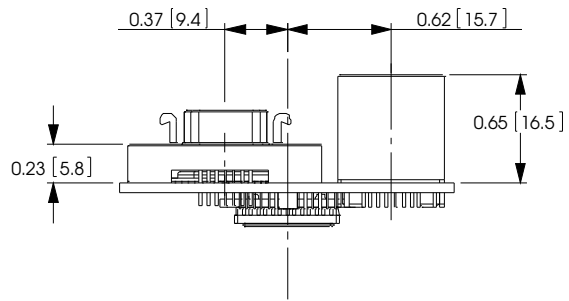
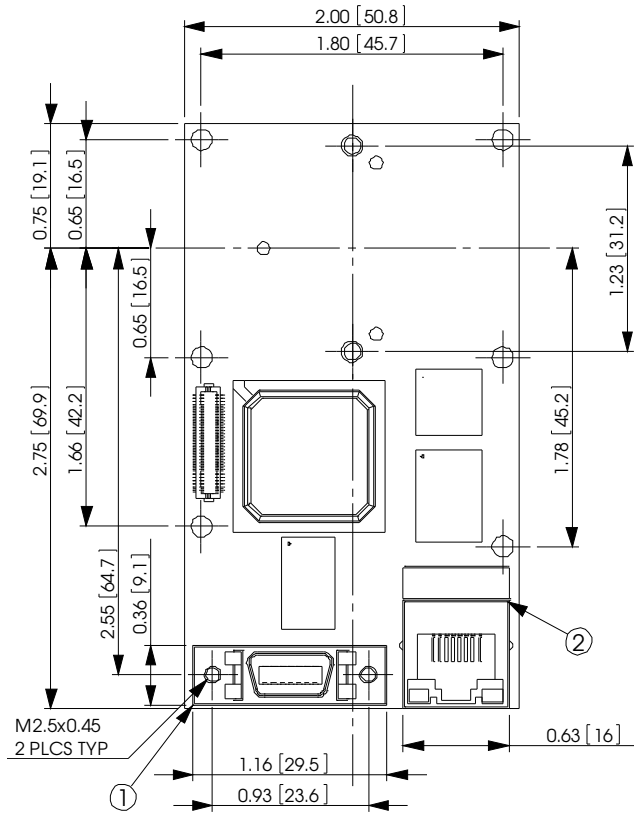


**MODEL: GB2450/GB2450C**

OPTIONS: LANDSCAPE/RIGHT ANGLE CONNECTORS

- ITEM 1: 3M 10214-55G3PC
- ITEM 2: HALO HFJ11-1G16E-L12RL
- ITEM 3: SONY ICX625

INCHES(MILLIMETERS)

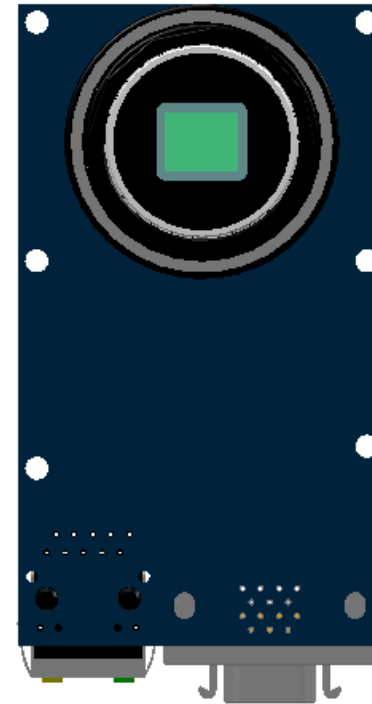
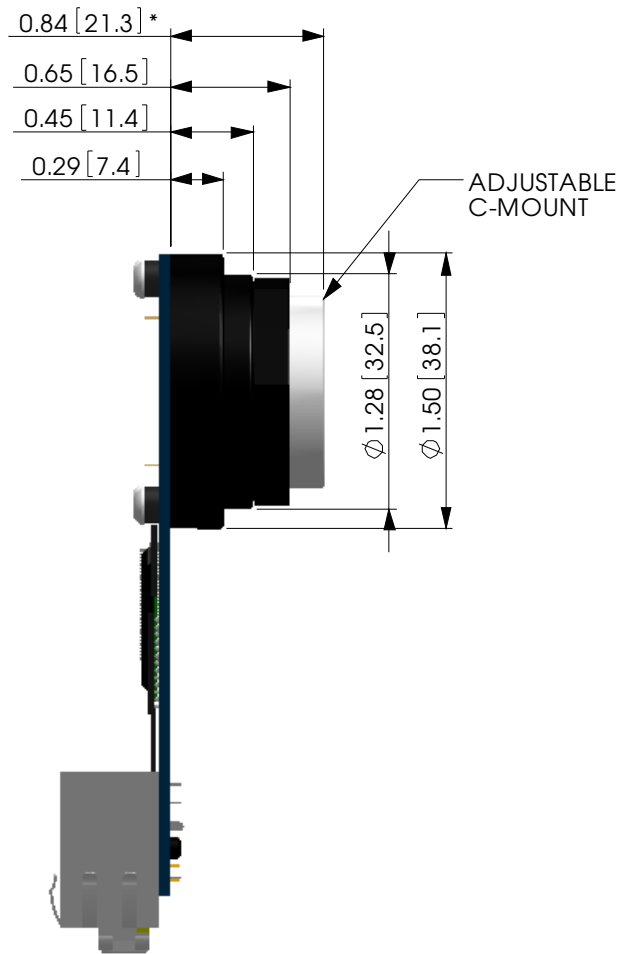


**MODEL: GB2450-V/GB2450C-V**

OPTIONS: LANDSCAPE/VERTICAL CONNECTORS

ITEM 1: 3M 10214-6212PC  
 ITEM 2: HALO HFJV1-E1G16-L12RL  
 ITEM 3: SONY ICX625

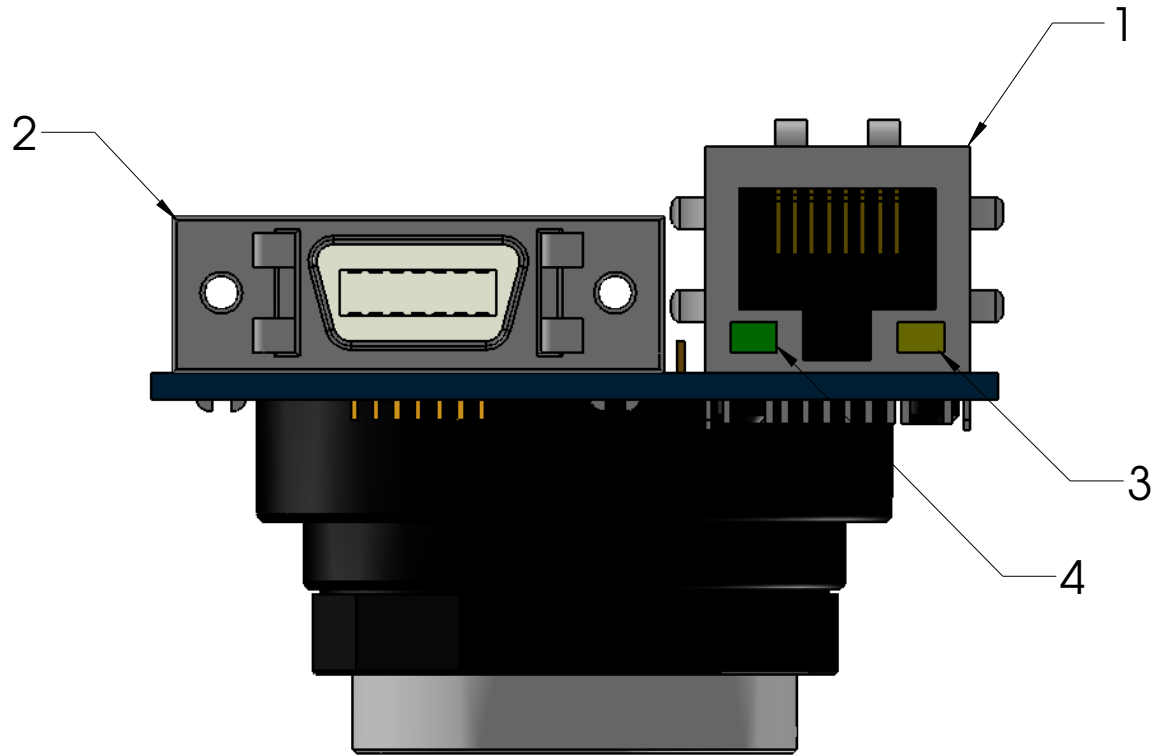
INCHES(MILLIMETERS)



\*Nominal value. This dimension will vary depending on CCD type.

INCHES(MILLIMETERS)

# Connections

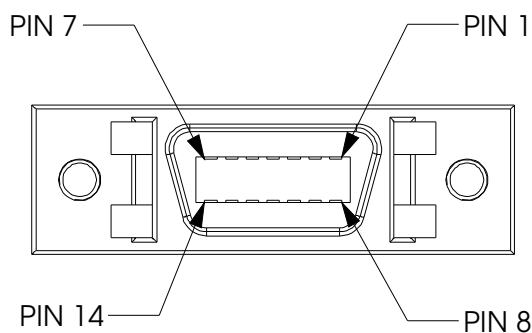


**Figure 1. GB SERIES connection diagram.**

## Item 1: GIGABIT ETHERNET PORT

This port conforms to the IEEE 802.3 1000BASE-T standard for Gigabit Ethernet over copper. It is recommended that CAT5E or CAT6 compatible cabling and connectors be used for best performance. Cable lengths up to 100m are supported.

## Item 2: General Purpose I/O PORT



**Figure 2. General Purpose I/O Pin out. Camera rear view.**

PIN	FUNCTION
1	12V POWER
2	GND POWER
3	Sync Input 1 - isolated
4	Isolated Ground
5	Sync Output 1 - isolated
6	Video Iris
7	DNC
8	12V POWER
9	GND POWER
10	RS-232 TXD
11	RS-232 RXD
12	Sync Input 2 – non-isolated
13	Sync Output 2 – non-isolated
14	GND SIGNAL

The General Purpose I/O port uses a 3M 10214-55G3PC (or 3M 10214-6212PC) connector on the camera side. The mating cable connector is 3M 10114-3000PE with shielded housing 3M 10314-3210-00X (X indicates color preference). This connector can be purchased from Prosilica or from <http://www.digikey.com>.

**See Addendum for more detail.**



**DO NOT EXCEED 5.5V ON SIGNAL INPUTS UNLESS OTHERWISE INDICATED. SYNC INPUT 1 CAN BE DRIVEN FROM A HIGHER VOLTAGE IF A CURRENT LIMITING RESISTOR IS USED TO LIMIT THE CURRENT TO LESS THAN 10 MILLIAMPS.**

***12V Power and Power Ground***

To operate the camera 12V Power with suitable current capacity (see specifications) must be provided on Pin 1 and the Power Ground on Pin 2.

A cable assembly providing this power can be ordered from Prosilica (Prosilica P/N 02-8007A for North America or Prosilica P/N 02-8008A for a Universal supply).

***Sync Input 1 and Sync Input 2***

These input signals allow the camera to be synchronized to some external event. The camera can be programmed to trigger on the rising edge, falling edge, both edges or level of this signal. The camera can also be programmed to capture an image at some programmable delay time after the trigger event.

Sync Input 1 is isolated and should be used in noisy environments to prevent false triggering due to ground loop noise. Sync Input 2 is non-isolated and can be used when a faster trigger is required and when environmental noise is not a problem.

***Sync Output 1 and Sync Output 2***

These signals only function as outputs and can be configured as follows:

Exposing	Corresponds to when camera is integrating light.
Trigger Ready	Indicates when the camera will accept a trigger signal.
Trigger Input	A relay of the trigger input signal used to “daisy chain” the trigger signal for multiple cameras.
Readout	Valid when camera is reading out data.
Imaging	Valid when camera is exposing or reading out.
Strobe	Programmable pulse based on one of the above events.
GPO	User programmable binary output.

Any of the above signals can be set for active high or active low.

Sync Output 1 will require a pull up resistor of greater than 1Kohm to the user’s 5V logic supply.

Sync Output 1 is isolated and should be used in noisy environments. Sync Output 2 is non-isolated and can be used when environmental noise is not a problem and when faster response is required.

***RS-232 RXD and RS-232 TXD***

These signals are RS-232 compatible. These signals allow communication from the host system via the Ethernet port to a peripheral device connected to the camera. Note that these signals are

not isolated and therefore careful attention should be used when designing cabling in noisy environments.

***Isolated Ground***

Isolated Ground must be connected to the user's external circuit ground if Sync Input 1 or Sync Output 1 is to be used.

***Signal Ground***

Signal Ground must be connected to the user's external circuit ground if Sync Input 2 or Sync Output 2 is to be used or if the RS-232 port is to be used. Note that Signal Ground is common with Power Ground however it is good practice to provide a separate ground connection for power and signaling when designing the cabling.

***Video Iris***

This signal can be used to drive the video input of a video iris lens. See Addendum.

***DNC***

These signals are reserved for future use and should be left disconnected.

**Item 3: Status LED 1**

<b>LED COLOR</b>	<b>STATUS</b>
Solid Orange	Ethernet link established.
Flashing Orange	Ethernet activity.

**Item 4: Status LED 2**

<b>LED COLOR</b>	<b>STATUS</b>
Solid Green	Normal operation.
Flashing once per second	Boot up pending
3 quick flashes once per second.	Camera fault.

# Cleaning the Sensor



**DO NOT CONTACT CLEAN SENSOR UNLESS ABSOLUTELY NECESSARY.**

## Identifying Debris

Debris on the image sensor or optical components will appear as a darkened area or smudge on the image that does not move as the camera is moved. Do not confuse this with a pixel defect which will appear as a distinct point.

## Locating Debris

Before attempting to clean the image sensor, it is important to first determine that the problem is due to debris on the sensor window. To do this you should be viewing a uniform image, such as a piece of paper, with the camera. Debris will appear as a dark spot or dark region that does not move as the camera is moved. To determine that the debris is not on the camera lens, rotate the lens independent of the camera. If the spot moves as the lens moves, then the object is on the lens -not on the image sensor- and therefore cleaning is not required. If the camera has an IR filter, then rotate the IR filter. If the object moves then the particle is on the IR filter not the sensor. If this is the case remove the IR filter carefully using a small flat head screw driver. Clean both sides of the IR filter using the same techniques as explained below for the sensor window.



**DO NOT TOUCH ANY OPTICS WITH FINGERS. OIL FROM FINGERS CAN DAMAGE FRAGILE OPTICAL COATINGS.**

## Cleaning with Air

If it is determined that debris is on the sensor window, then remove the camera lens, and blow the sensor window directly with clean compressed air. If canned air is used, do not shake or tilt the can prior to blowing the sensor. View a live image with the camera after blowing. If the debris is still there, repeat this process. Repeat the process a number of times with increased intensity until it is determined that the particulate cannot be dislodged. If this is the case then proceed to the contact cleaning technique.

## Contact Cleaning

Only use this method as a last resort. Use 99% laboratory quality isopropyl alcohol and clean cotton swabs. Dampen the swab in the alcohol and gently wipe the sensor in a single stroke. Do not reuse the same swab. Do not wipe the sensor if the sensor and swab are both dry. You must wipe the sensor quickly after immersion in the alcohol, or glue from the swab will contaminate the sensor window. Repeat this process until the debris is gone. If this process fails to remove the debris, then contact Prosilica.

## Adjusting the C-mount

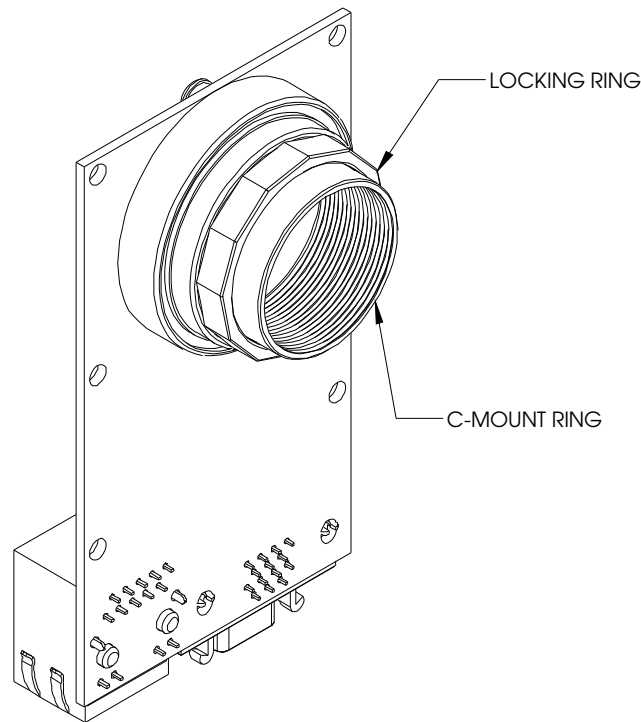


Figure 3. Camera Front View.



**THE C-MOUNT IS ADJUSTED AT THE FACTORY AND SHOULD NOT REQUIRE ADJUSTING.**

If for some reason, the C-mount requires adjustment, use the following method.

### Loosen Locking Ring

Use an adjustable wrench to loosen locking ring. Be careful not to scratch the camera. When the locking ring is loose, unthread the ring a few turns from the camera face. A wrench suitable for this procedure can be provided by Prosilica (P/N 11-0048A).

### Image to Infinity

Use a c-mount compatible lens that allows an infinity focus. Set the lens to infinity and image a distant object. The distance required will depend on the lens used but typically 30 to 50 feet should suffice. Make sure the lens is firmly threaded onto the c-mount ring. Rotate the lens and c-mount ring until the image is focused. Carefully tighten locking ring. Recheck focus.

# Camera Installation

## Computer Interface

The Prosilica GB Series cameras will work with any Ethernet network card; however Prosilica strongly recommends using Gigabit Ethernet components that support Jumbo Frames. A Jumbo Frame is loosely defined as a frame size greater than 1500 bytes however typical Jumbo Frames are around 9000 bytes. Frame size is the number of bytes per packet and the larger the frame size, the less the computer CPU will be loaded due to the processing of incoming packets.

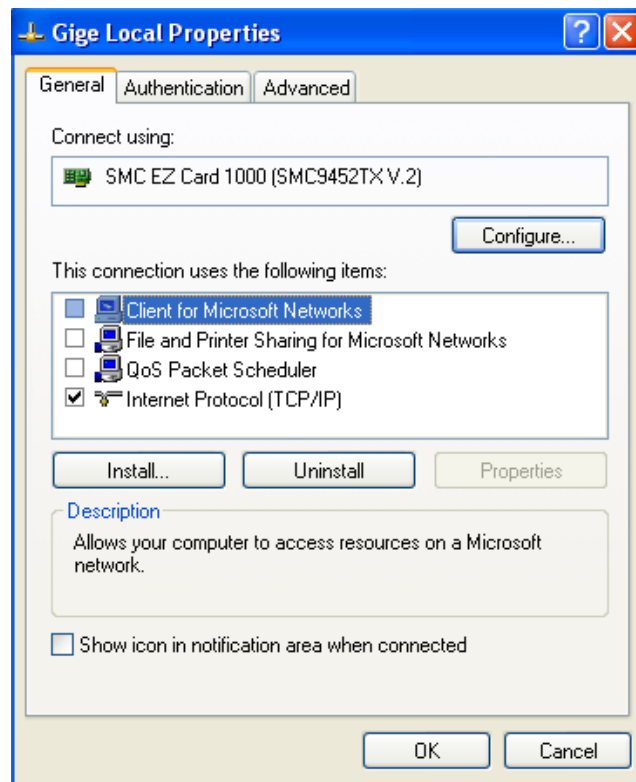
There are many Gigabit Ethernet cards available which will support Jumbo Frames. The following examples have been verified to work well with the Prosilica cameras:

- Intel PRO/1000
- D-Link DGE-550T
- SMC EZ Card 1000

Gigabit Ethernet cards supporting this feature can also be purchased with the camera (Prosilica P/N 02-3002A).

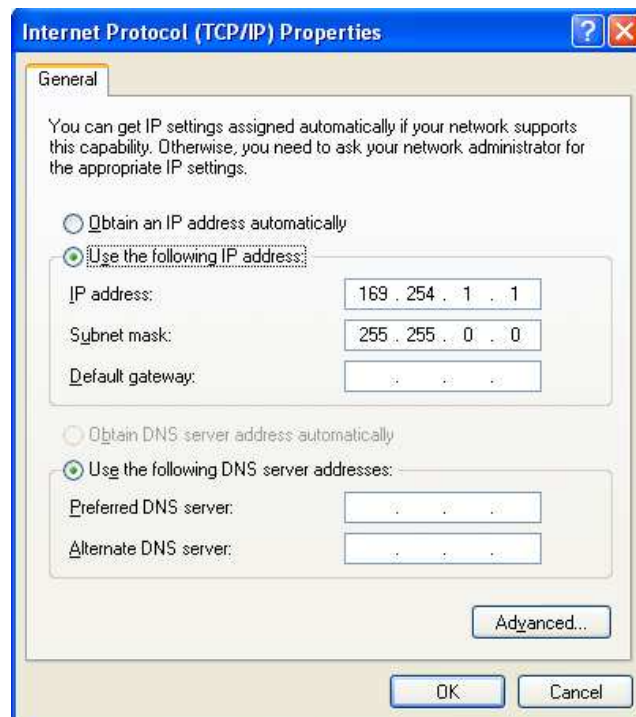
## Gigabit Ethernet Setup for Windows

- Install network card in computer.
- Boot the PC and cancel the “Found new Hardware Wizard” window that may appear when Windows detects the new card.
- Install the driver that came with the network card.
- Once the driver is installed, open the Network Connections Dialog as follows: From the Windows desktop select *start*, then select **Control Panel**, then double click on the **Network Connections** icon. Double click the relevant network card listed or right-click the relevant network card and select **Properties**. This will open the properties window for your network card. See Figure 4.

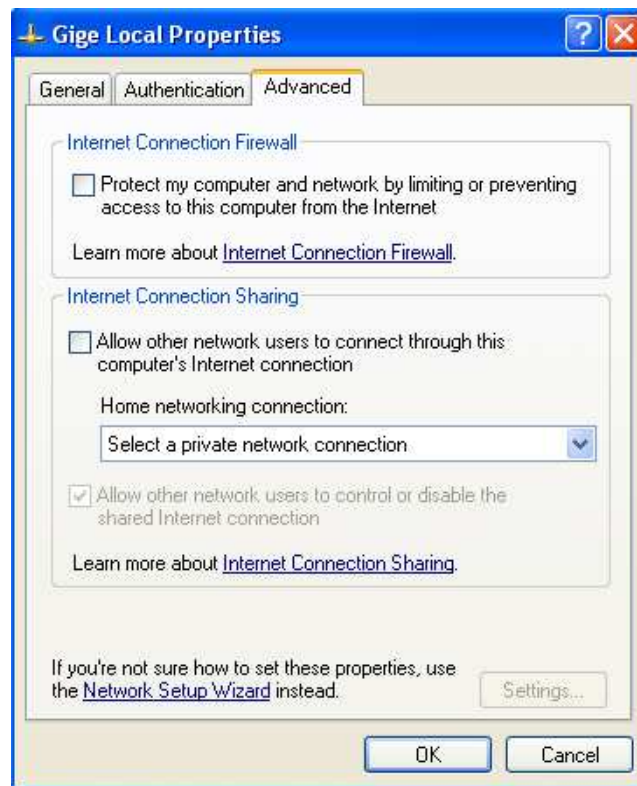


**Figure 4. Network card main properties window.**

- Select the **Internet Protocol (TCP/IP)** check box and then select **Properties**. See Figure 5. Network card TCP/IP address.. Select the **Use the following IP address** and enter an IP address of **169. 254. x. y**, where **x** and **y** can be any number. Press the TAB key after entering the IP address and the subnet mask will automatically be entered. The subnet mask is **255. 255. 0. 0**. Click **OK** to save changes. Note that if Windows reports a conflict with the above IP address, simply repeat the above steps and change the last digit of the IP address to a different value.



**Figure 5. Network card TCP/IP address.**



**Figure 6. Turn off Firewall.**

- Return to the Gige Local Properties window as in Figure 4. Select the Advanced tab as in Figure 6 and disable the Firewall for this device. Click **OK** to save changes.

## Gigabit Ethernet Cabling

All Gigabit Ethernet cabling and connectors should be CAT5E or CAT6 compatible. Cable lengths must not exceed 100 meters.

## Power Connection

The camera requires a 12V DC power supply that can source a minimum of 500 mA of current. See the Connections section of this document for more information.

## Installing GigE Viewer for Testing

- The latest Viewer software can be downloaded from <http://www.prosilica.com/support.htm>.
- Run the GigE Viewer Installer.exe. This will install the Prosilica Digital Camera drivers as well as the Prosilica GigE Viewer application program.
- Plug in the Prosilica camera via the Gigabit Ethernet port. Plug in the power connection. Verify that the Status LED 2 is a solid green. Run the Prosilica GigE Viewer Application. It will take a few seconds for the camera to be recognized. If the camera does not appear in the Viewer list after approximately 10 seconds then try disconnecting and reconnecting the power. If it still does not appear restart the viewer. If it still does not appear, see the Trouble Shooting section of this document.
- See Figure 7. Select the *wrench* icon to change camera settings. Change the PacketSize to a value of 1500. Select the *eye* icon to image. The camera should now be imaging. If the camera is not imaging, see the Trouble Shooting section of this document. Note that the PacketSize can be set to 8228 if the network card has been optimized to support jumbo frames.
- See the System Optimization Section to maximize the performance of your system.

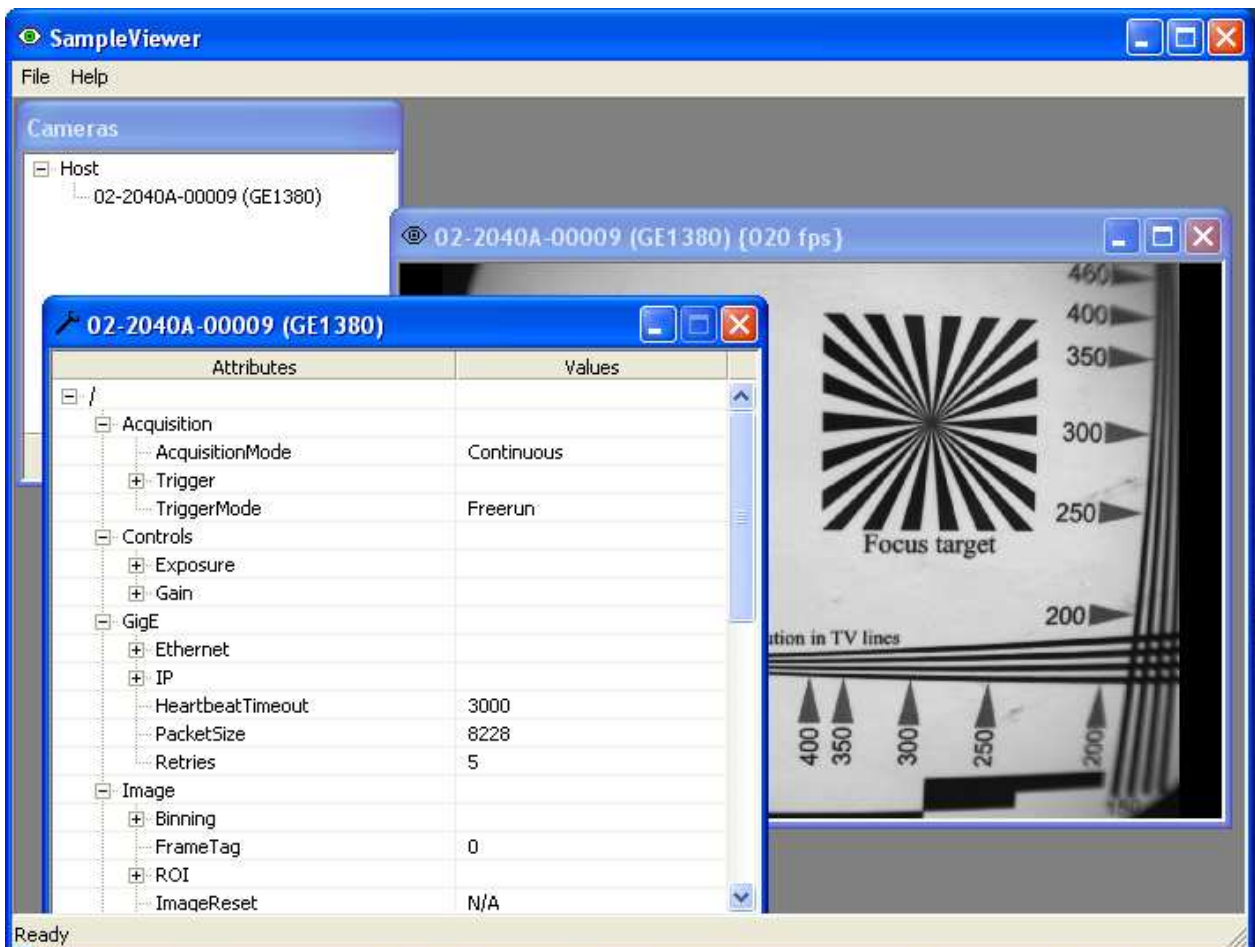
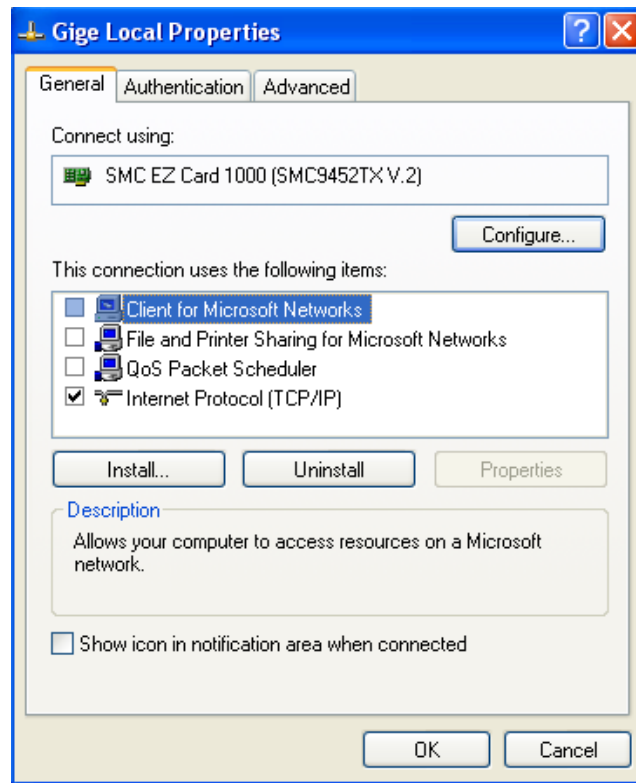


Figure 7. GigE Viewer application window.

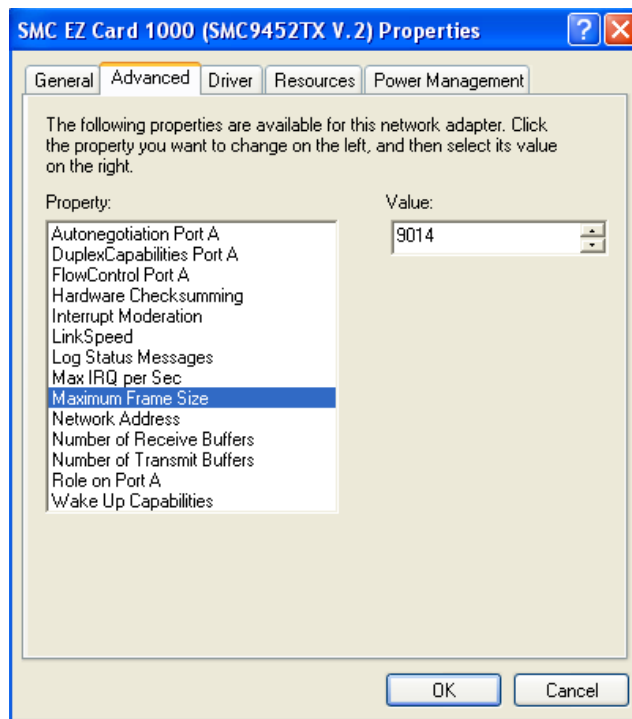
## System Optimization

- Open the Network Connections Dialog as follows: From the Windows desktop select *start*, then select *Control Panel*, then double click on the *Network Connections* icon. Double click the relevant network card listed or right-click the relevant network card and select *Properties*. This will open the properties window for your network card. See Figure 8.



**Figure 8. Network card main properties window.**

- From the Properties window select *Configure* then select the *Advanced* tab. See Figure 9.



**Figure 9. Network card advanced settings.**

- Set **Maximum Frame Size** or **Jumbo Frames** to the maximum possible value. A typical value is **9000**. If the list contains a property called **Receive Descriptors**, then change this value to its maximum value. Select **OK** to save properties.
- From the main properties dialog as in Figure 8, make sure that only the **Internet Protocol (TCP/IP)** check box is selected then click **OK**. The card is now optimized for use with the Prosilica camera.
- Open the viewer and set the PacketSize to 8228.

# Trouble Shooting

## Check the Basics

- Is power available? Check the status LED 2. If the LED is off, the camera is not getting power. Verify the connections and cabling.
- Is the LED 2 flashing once per second? This occurs if the firmware is corrupt because a firmware update was interrupted. If this is the case, run the firmware updater again, carefully following the instructions. If the problem persists, contact Prosilica.
- Is the LED flashing 3 times once per second? This indicates a fault with the camera. If this problem persists, please contact Prosilica.

## Test the Camera with the Prosilica Viewer

Download and install the Prosilica Viewer (from <http://www.prosilica.com/support.htm>).

- Can the Viewer find the camera? Is the camera listed in the main application window or is the list empty? If the camera is not listed, proceed to **Driver Issues**.
- Is the image black? If so, check the optics. Check that lens iris is fully open. Check exposure time - in room lighting, an exposure time of 30ms should be adequate to see an image. If image is still black, contact Prosilica.
- Is the image white?
  - If the camera is in external trigger mode, a snapshot will not complete until a hardware trigger is received.
  - Image data may fail to arrive at the computer if there is a problem with the driver. If you suspect a driver problem, proceed to **Driver Issues**.
- Is the image white, but the camera is not waiting for an external trigger? Do you have a lens? Check your exposure time, offset, and gain controls.
- Does the image occasionally freeze? Test the camera with an alternate Ethernet cable and card. If the problem persists, contact Prosilica.
  - An intermittent connection will result in the loss of image data, but you likely will not notice a problem when using the camera controls.

## Driver Issues

TBD.

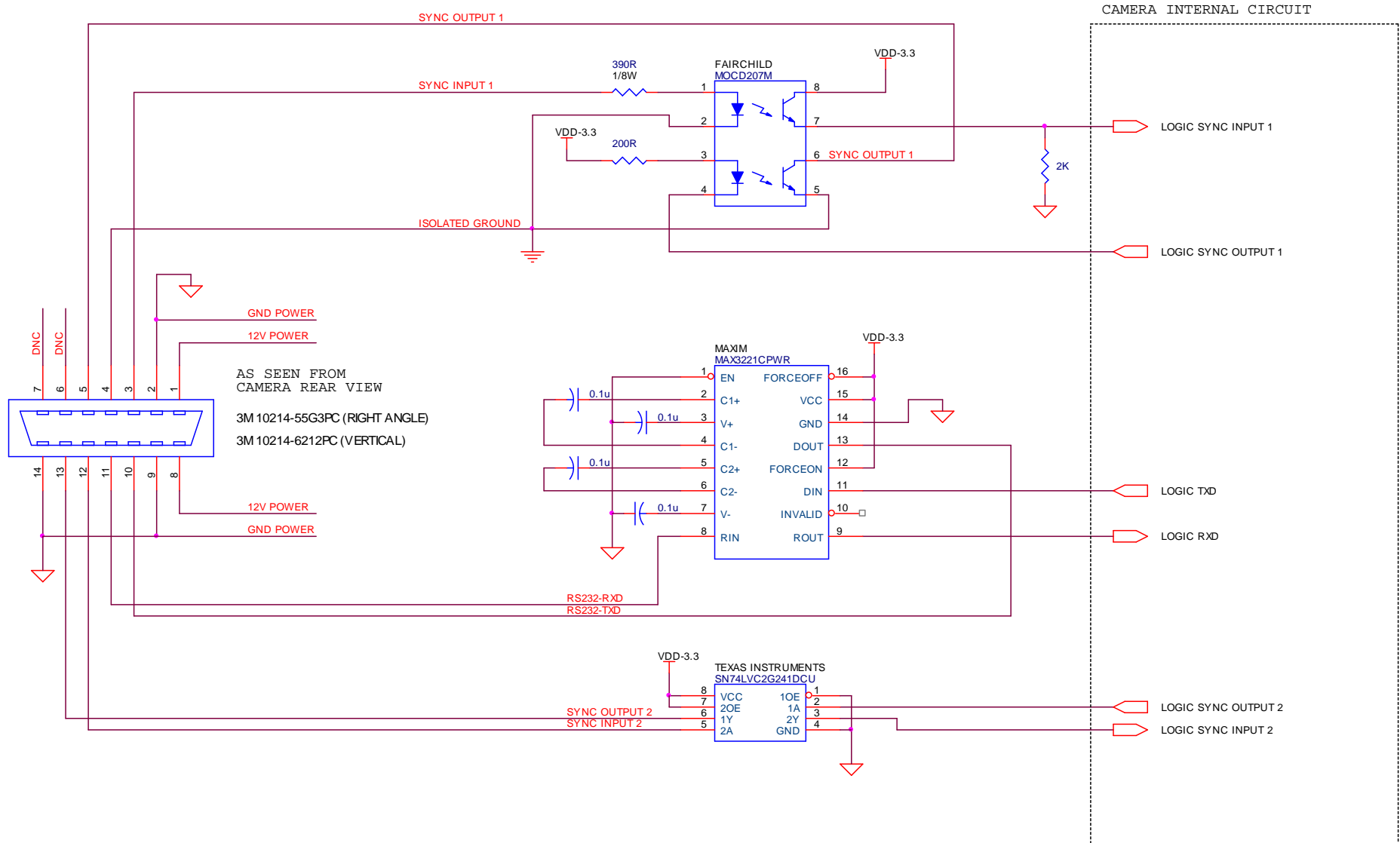
## Camera will not trigger

Check cabling and connections. Verify that external trigger circuit is providing a compatible trigger signal. Use the Prosilica Viewer program in trigger mode to eliminate possible software issues.

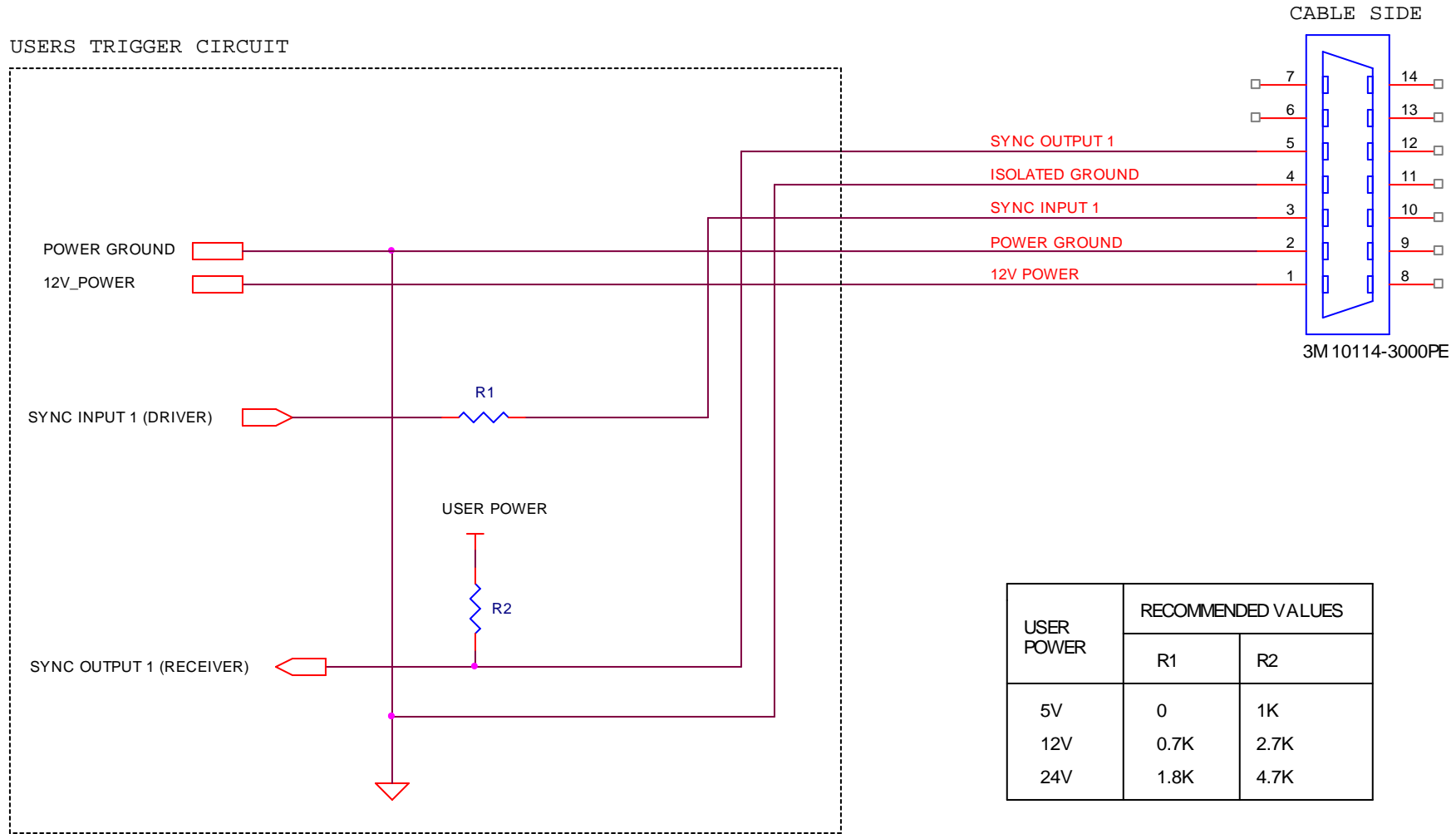
# Addendum

---

# GB IO Schematic

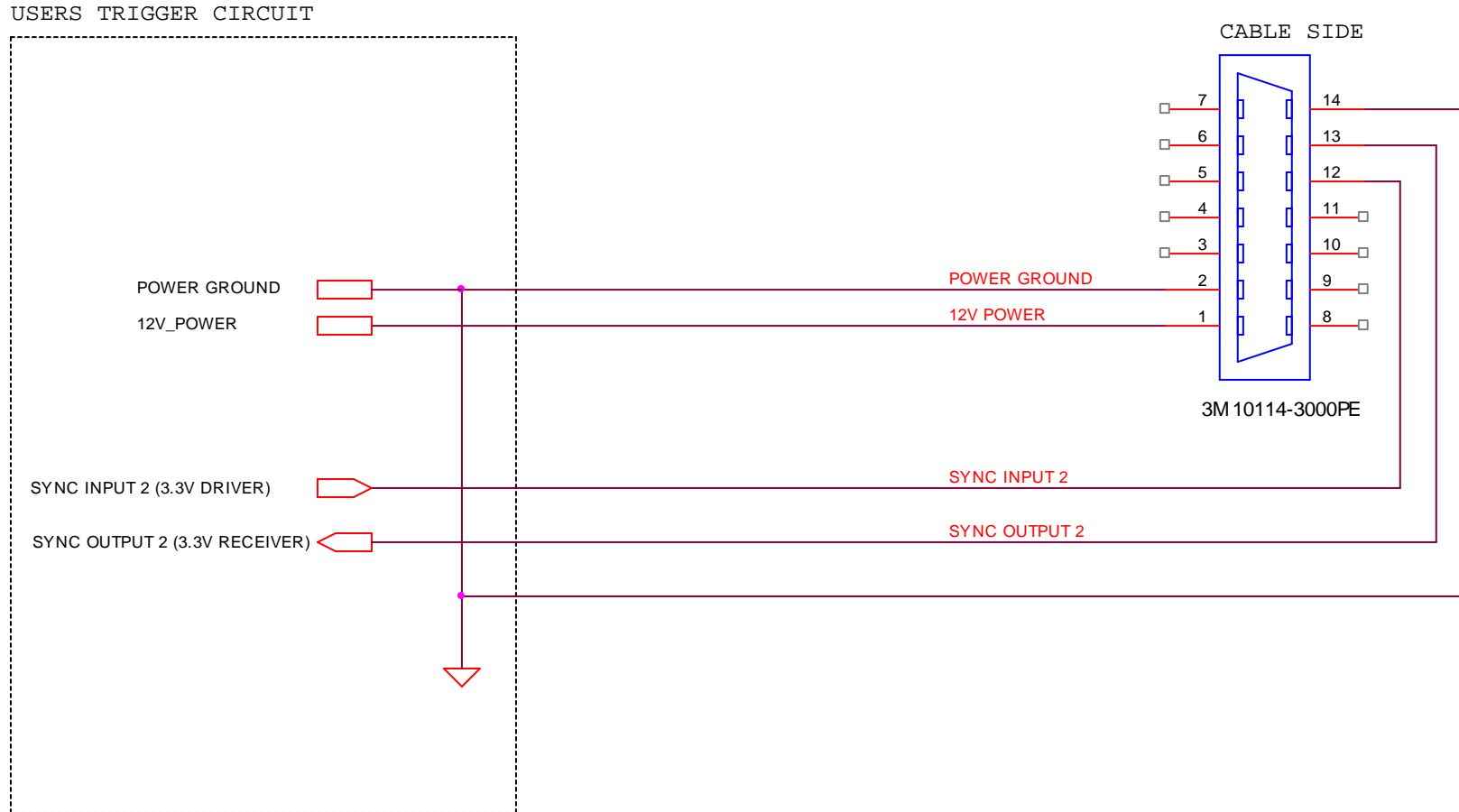


# Isolated Trigger Schematic



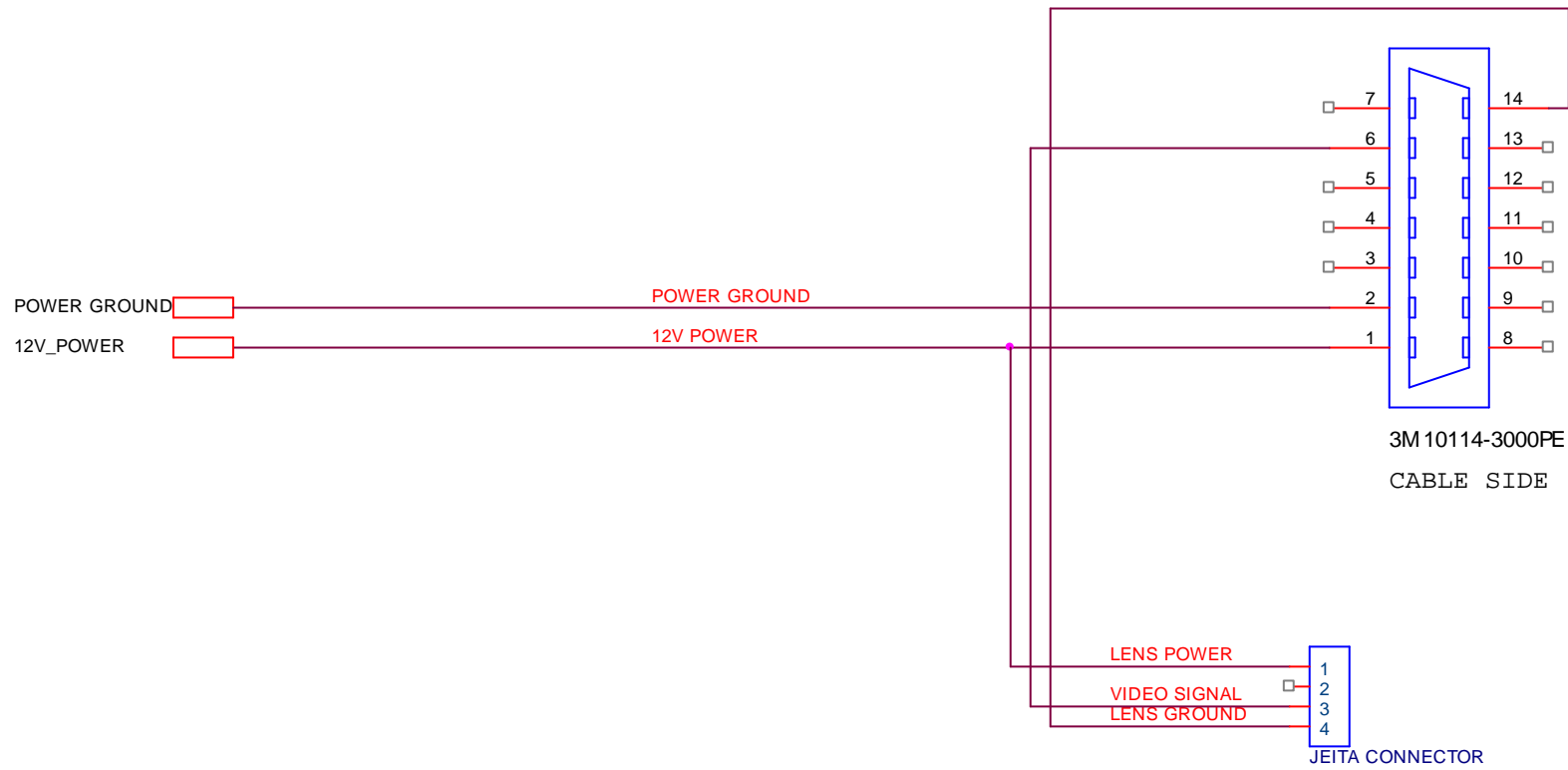
This circuit assumes a 10mA drive current ( $I_F$ ) from User's trigger circuit into camera through R1. R2 is connected to the open collector of Fairchild MOCD207. The corresponding transistor emitter is connected to isolated ground. See the Fairchild MOCD207 datasheet for more detailed information.

# Non-isolated Trigger Schematic

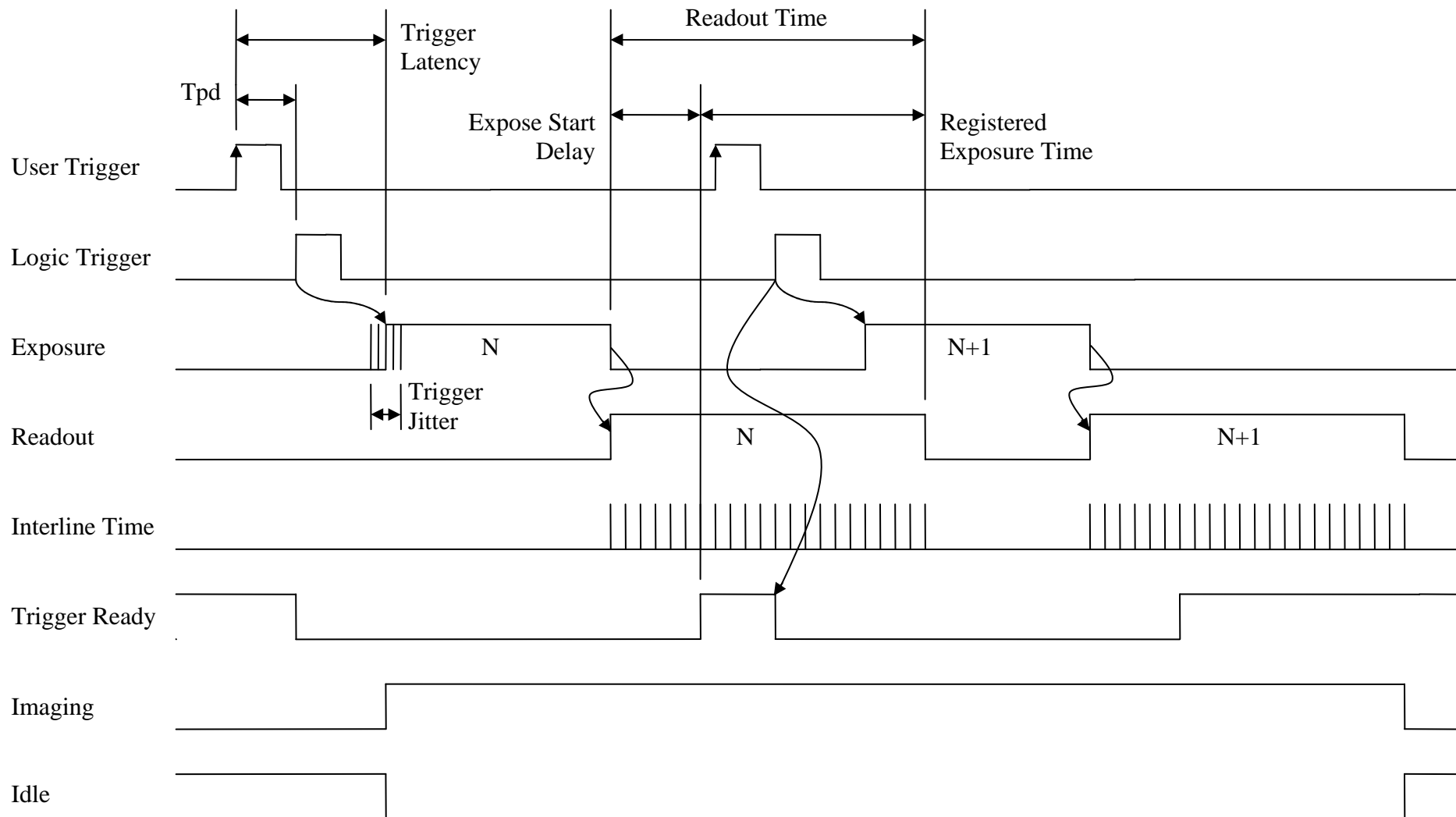


The non-isolated trigger circuit is connected to a Texas Instruments SN74LVC2G241 buffer/driver inside the camera. The required sync input current is less than 10uA and the maximum sync output current is 24mA. See the Texas Instruments SN74LVC2G241 for more detailed information.

# Video Iris Schematic



# Trigger Timing Diagram



# Notes on Triggering

## Definitions

- User Trigger is the trigger signal applied by the user.
- Logic Trigger is the trigger signal seen by the camera internal logic.
- Tpd is the propagation delay between the User Trigger and the Logic Trigger.
- Exposure is high when the camera image sensor is integrating light.
- Readout is high when the camera image sensor is reading out data.
- Trigger Latency is the time delay between the User Trigger and the start of Exposure.
- Trigger Jitter is the error in the Trigger Latency time.
- Trigger Ready indicates to the user that the camera will accept the next trigger.
- Registered Exposure Time is the Exposure Time value currently stored in the camera memory.
- Expose Start Delay is the delay time from the start of Exposure to valid Trigger Ready. It is the Registered Exposure Time subtracted from the Readout time and indicates when the next Exposure cycle can begin such that the Exposure will end after the current Readout.
- Interline Time is the time between sensor row readout cycles.
- Imaging is high when the camera image sensor is either exposing and/or reading out data.
- Idle is high if the camera image sensor is not exposing and/or reading out data.

## Rules

- The User Trigger pulse width should be at least three times the width of the Trigger Latency as indicated in the Specifications section of this document.
- The end of Exposure will always trigger the next Readout.
- The end of Exposure must always end after the current Readout.
- The start of Exposure must always correspond with the Interline Time if Readout is true.
- Expose Start Delay equals the Readout time minus the Registered Exposure Time.

## Triggering during the Idle State

- For applications requiring the shortest possible Trigger Latency and the smallest possible Trigger Jitter the User Trigger signal should be applied when Imaging is false and Idle is true.
- In this case, Trigger Latency and Trigger Jitter are as indicated in the Specifications section.

**Triggering during the Readout State**

- For applications requiring the fastest triggering cycle time whereby the camera image sensor is exposing and reading out simultaneously, then the User Trigger signal should be applied as soon as a valid Trigger Ready is detected.
- In this case, Trigger Latency and Trigger Jitter can be up to 1 line time since Exposure must always begin on an Interline boundary.