



See the possibilities

User's Manual

CM-200 MCL

CB-200 MCL

*Digital Monochrome / Color
Compact Mini-CL Camera*

Document Version: 1.0

Camera Revision: 0

CM-200 MCL / CB-200 MCL

1.	1. General.....	3
2.	2. Camera nomenclature	3
3.	3. Main Features	3
4.	4. Locations and Functions	4
5.	Pin Assignment.....	5
5.1.	12-pin Multi-connector (DC-IN/Trigger).....	5
5.2.	Digital Output Connector for Mini-CL (Camera Link).....	5
5.3.	Input and output circuits	6
5.3.1.	Iris video output	6
5.3.2.	Trigger input	6
5.3.3.	XEEN output	6
5.3.4.	Camera Link interface	6
6.	Functions and Operations	7
6.1.	Basic functions	7
6.1.1.	Digital Output Bit Allocation.....	7
6.1.2.	Electronic Shutter	7
6.1.3.	Continuous operation or triggered operation	8
6.1.4.	Iris video output	8
6.1.5.	Rear Panel indicator	8
6.1.6.	Auto-detect LVAL-sync / - a-sync accumulation	9
6.1.7.	Starting pixel - Bayer color mosaic	9
6.1.8.	Vertical Binning	10
6.2.	Sensor Layout and timing.....	11
6.2.1.	CCD Sensor Layout	11
6.2.2.	Horizontal timing.....	12
6.2.3.	Vertical timing.....	12
6.2.4.	Partial Scanning	13
6.2.5.	Vertical Binning.....	14
6.3.	Operation Modes	15
6.3.1.	Continuous operation	15
6.3.2.	Edge Pre-select Trigger Mode	15
6.3.3.	Pulse Width Control Trigger Mode	17
6.4.	Mode and function matrix.	18
7.	Configuring the Camera	19
7.1.	CL-seriel control	19
7.2.	Setting functions.....	20
7.2.1.	Bit allocation BA=0, BA=1	20
7.2.2.	Partial scan SC=0 through 4.....	20
7.2.3.	Vertical binning VB=0, VB=1.....	20
7.2.4.	Shutter mode SM=0 and SM=1.....	20
7.2.5.	Trigger input select TI=0, TI=1.	20
7.2.6.	Trigger polarity. TP=0, TP=1.	20
7.2.7.	Gain level GA= -84 through +336.....	20
7.2.8.	Black level BL=0 through BL=1023.	20
7.3.	Save and Load Functions.....	20
7.4.	CM-200MCL/CB-200MCL command list.....	21
8.	Camera Control Tool for CM-200MCL / CB-200MCL	23
8.1.	Camera Control Tool Interface	23
8.1.1.	Camera Control Tool Bar	23
8.2.	The About Window.....	23
8.3.	Communication Window	24
8.4.	Camera Control Window	25



8.5.	Using the Camera Control Tool	25
9.	External Appearance and Dimensions	27
10.	Specifications	28
10.1.	Spectral response	28
10.2.	Specification table	29
11.	Appendix	30
11.1.	Precautions	30
11.2.	Typical Sensor Characteristics	30
11.3.	References	31
12.	User's Record	33

1. General

CM-200 MCL is a monochrome progressive scan CCD camera and CB-200 MCL is the equivalent Bayer mosaic progressive scan CCD camera. Both have 2.0M pixels resolutions.

These camera are suitable for a wide range of applications within factory automation, an also for applications outside the factory floor, such as ITS (Intelligent Traffic Solutions), high-end surveillance and medical.

The latest version of this manual can be downloaded from: www.jai.com

The latest version of Camera Control Tool for CM-200MCL/CB-200MCL can be downloaded from: www.jai.com

For camera revision history, please contact your local JAI distributor.

2. Camera nomenclature

The standard camera composition consists of the camera main body and C-mount protection cap.

The camera is available in the following versions:

CM-200 MCL

Where C stands for "Compact" family, M stands for "Monochrome", 200 represents the resolution "2 million pixel" and MCL stands for "Mini-CL" interface

CB-200 MCL

Where C stands for "Compact" family, B stands for "Bayer mosaic color", 200 represents the resolution "2 million pixel" and MCL stands for "Mini-CL" interface

3. Main Features

- Compact series 1/1.8 inch progressive scan camera
- Monochrome and Bayer mosaic color versions
- 1620 (h) x 1236 (v) active pixels
- 4.4 μm square pixels
- 25 frames / second with full resolution in continuous operation
- 24 frames / second with external trigger and full resolution
- Up to 99 frames with partial scan
- 49 frames / second with vertical binning (CM-200 MCL only)
- Shutter speed from 32 μs to 2 second (48 frames) using pulse width control
- Programmable exposure from 64 μs to 40 ms
- Pre-Select and Pulse Width control trigger modes
- LVAL -synchronous /-asynchronous operation (auto -detect)
- Power over CL (PoCL) version available
- Auto iris lens video output allows a wider range of light
- 10 bit or 8 bit output
- Set up by Windows NT/Win 2000/ XP via serial communications

4. Locations and Functions

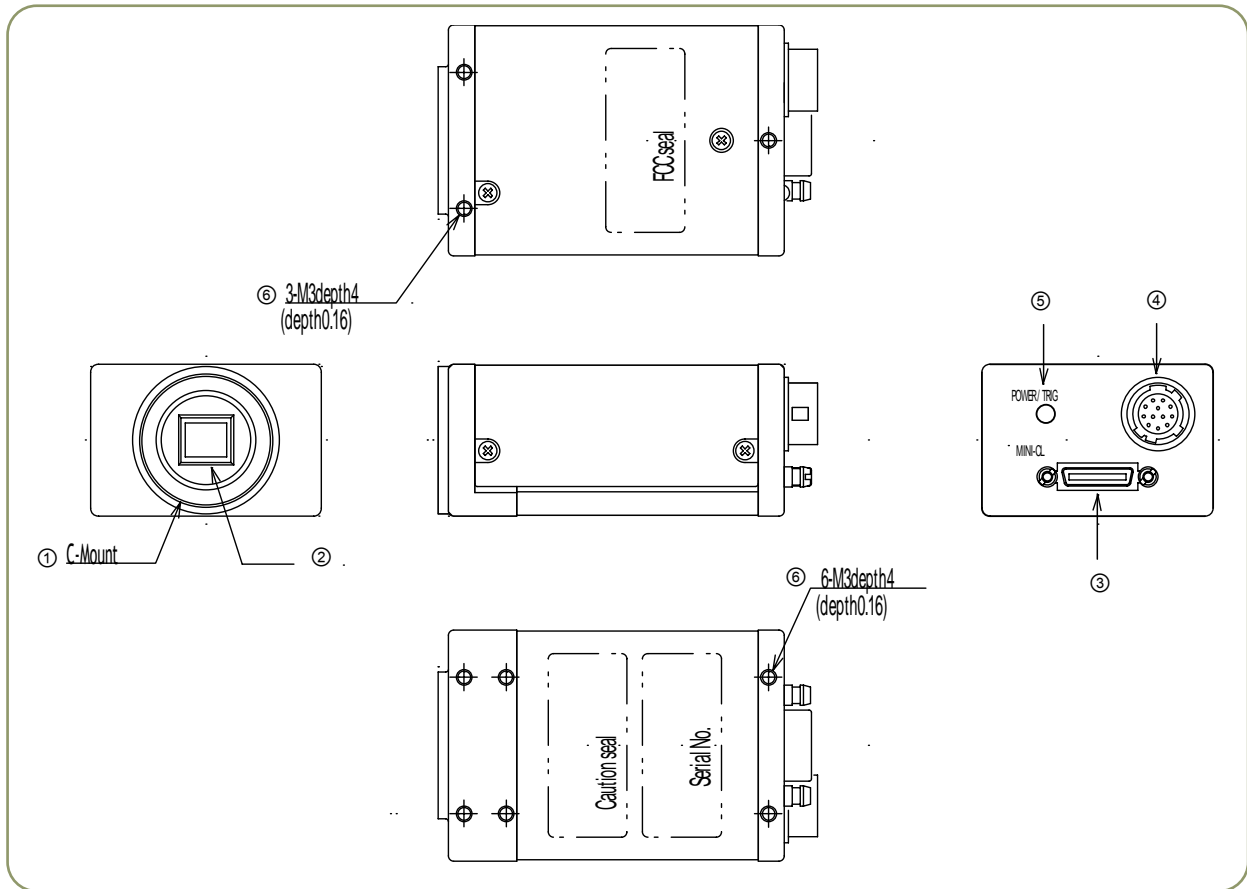

- ① Lens mount
- ② CCD sensor
- ③ 26-pin connector
- ④ 12-pin connector
- ⑤ LED
- ⑥ Mounting holes

- C-mount (Note *1)
- 1/2 inch CCD sensor
- Camera Link Interface (Mini-CL)
- DC+12V and trigger input (Note *2)
- Indication for power and trigger input
- M3 depth 4mm for tripod mount plate

*1) Note: Rear protrusion on C-mount lens must be less than 10.0mm.

*2) Note: Cameras with the PoCL (Power-over-CL) option do not have the 12-pin connector

Fig. 1. Locations

5. Pin Assignment

5.1. 12-pin multi-connector (DC-IN/Trigger)

Type: HR10A-10R-12PB-01(Hirose) male.

Use the part number HR10A-10P-12S for the cable side

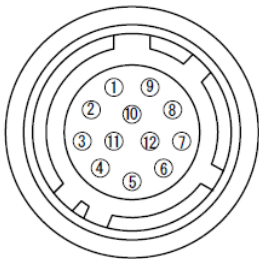

Fig. 2 Hirose 12-pin connector

Pin no.	Signal	Remarks
1	GND	
2	+12 V DC input	
3	GND	
4	Iris video	Only for Continuous mode. TR=0
5	GND	
6	NC	
7	NC	
8	GND	
9	XEEN out	
10	Trigger in	TI=1. Or Camera Link (TI=0). *1)
11	DC+12V	
12	GND	

* Note: Factory default is trigger via Camera Link

Important note:

This camera is also available in a Power over Camera Link (PoCL) version. In this case the 12-pin Hirose multi connector is not present on the rear panel.

PoCL cameras require special frame grabbers that provide power to the camera via the Camera Link cable. Please consult www.jai.com (3rd party interfacing section) for information on available PoCL frame grabbers.

5.2. Digital Output Connector for Mini-CL (Camera Link)

Type: 26 pin SDR connector (3M or Honda type) Mini-CL connector



Fig.3. Mini-CL connector

Pin No	I/O	Name	Note
1,13,14,26		GND	DC GND
7(+),20(-)	I/O	RXD	Serial Com.
8(-),21(+)	O	TXD	
10(+),23(-)	I	Reserve	
9(-),22(+)	I	Trigger	CC1 Ext. Trigger in
6(-),19(+)	O	TxOUT3	Camera Link out
4(-),17(+)	O	TxOUT2	
3(-),16(+)	O	TxOUT1	
2(-),15(+)	O	TxOUT0	
5(-),18(+)	O	TxCk	Clock for CL

5.3. Input and output circuits

In the following schematic diagrams the input and output circuits for video and timing signals are shown.

5.3.1. Iris video output

This signal can be used for lens iris control in Continuous mode. The signal is taken from the CCD sensor output before the gain circuit. The video output is without sync. The signal is 0.7 V_{pp} from 75 Ω without termination.

NOTE: This function is not available in the PoCL version

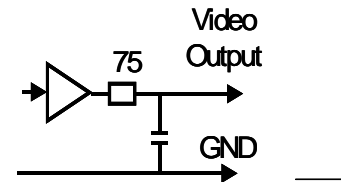

Fig. 4. Video output.

5.3.2. Trigger input

An external trigger input can be applied to pin 10 of 12-pin Hirose connector (when the command TI=1 has been set). The input is AC coupled. To allow long pulses the input circuit is designed as a flip-flop circuit. The leading and trailing edges of the trigger pulse activate the circuit.

The trigger polarity can be changed by TP=1.

Trigger input level 4 V ±2 V.

The trigger can also be supplied through the Camera Link connector, when the command TI=0 has been set.

NOTE: In the PoCL version trigger can only be applied through the Camera Link connector

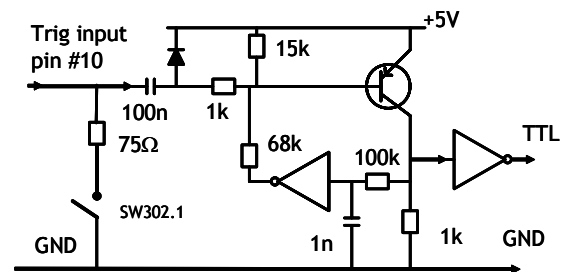

Fig. 5. Trigger input.

5.3.3. XEEN output

XEEN is on pin 9 on 12-pin HR connector. The output circuit is 75 Ω complementary emitter followers. It will deliver a full 5 volt signal.

Output level ≥4 V from 75Ω. (No termination).

EEN is also found in Camera Link.

NOTE: In the PoCL version EEN is only available in the Camera Link connector

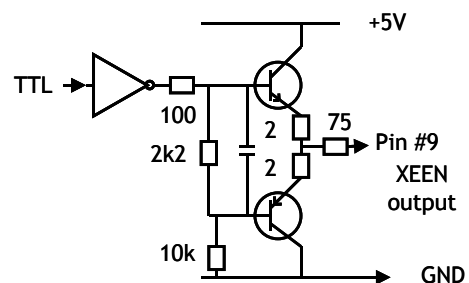

Fig. 6. XEEN output

5.3.4. Camera Link interface

The digital video is available via Camera Link, with 8 or 10-bit pixel depth, using the CL Base configuration. The digital output signals follow the Camera Link standard using Channel Link chip sets.

The data bits from the digital video, FVAL, LVAL, DVAL and EEN are multiplexed into the twisted pairs, which are a part of the Camera Link. Trigger signals and the serial camera control are feed directly through its own pairs.

The 26-pin Mini-CL SDR connector pin assignment follows the Camera Link base configuration.

For a detailed description of the Camera Link standard, please refer to the Camera Link standard specifications found at the AIA web site, www.machinevisiononline.org.

6. Functions and Operations

6.1. Basic functions

The CM-200 MCL / CB-200 MCL cameras are progressive scan camera with 2 Mega pixels monochrome and Bayer mosaic color CCDs . The interface to the host PC is via digital Mini Camera Link (Mini-CL). Both models output video as 8 bits or 10 bits. The CB-200 MCL outputs raw Bayer video requiring host based color interpolation.

An analogue iris video signal can be used for controlling the iris of an auto iris lens when operating in continuous mode.

The camera has 2/3, 1/2, 1/4 or 1/8 partial scanning and vertical binning (CM-200MCL only)for faster frame rates .

There are 2 trigger modes in addition to continuous operation . The Edge Pre-Select and Pulse Width Control are available with a unique automatic LVAL sync or a-sync selection function. Below the functions are described in details.

6.1.1. Digital Output Bit Allocation

The 10-bit digital output is set 890 LSB as 100% video level when CCD output is 200mV. The white clip level is set at 1023 LSB when CCD output is 230mV.

CCD out	Analogue Out	Digital Out
Black	Setup 3.6%, 25mV	32LSB
200mV	700mV	890LSB
230mV	800mV	1023LSB

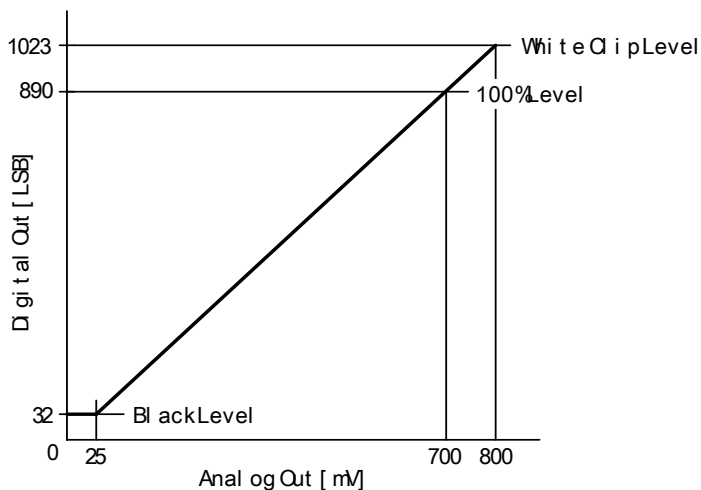

Fig.7. Digital Output Bit Allocation

6.1.2. Electronic Shutter

CM-200MCL / CB-200MCL camera allows selecting shutter in two ways ; preset shutter (10 fixed steps) and programmable exposure (in 1251 line period, LVAL increment).

Preset Shutter

The following 10 steps can be selected by command SH=0 through SH=9.
 OFF (1/25), 1/60, 1/100, 1/250, 1/500, 1/1000, 1/2000, 1/4000, 1/8000, 1/10000

Programmable Exposure (PE)

The Exposure time can be programmed in 32 μs (1 LVAL period) increments. The range is from 2L to 1251L.

Minimum shutter speed 2L	Maximum shutter speed 1251L
32μs x 2(L) = 64 μs	32μs x 1251 (L) ≈ 40.032ms

In vertical binning mode

Minimum shutter speed 2L	Maximum shutter speed 627L
35.846 μs x 2(L) = 71.692 μs	35.846 μs x 627 (L) ≈ 22.475 ms

6.1.3. Continuous operation or triggered operation

The camera can operate in continuous mode applications not requiring asynchronous external trigger. This mode permits the use of a lens with video controlled iris. The camera will operate at its maximum frame rate, 25 frames / second in this mode.

For applications that require an external trigger, the camera can accept an external trigger input on pin 10 of the 12-pin Hirose connector or via Camera Link interface. The command “TI” is used to switch between inputs.

The camera can operate up to 24 frames / second in triggered operation.

6.1.4. Iris video output

The iris video output in pin 4 on the 12-pin Hirose connector is 700 mV for 100% video out in Camera Link. The iris video signal is taken before the gain circuit. It is without sync. The iris video signal can be used for auto iris lens drive in continuous mode.

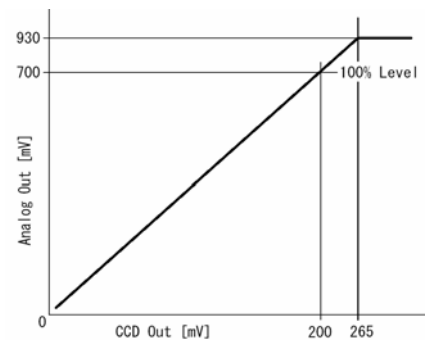
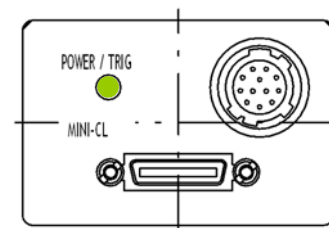

Fig. 8. Iris video output.

6.1.5. Rear Panel indicator

The rear panel mounted LED provides the following information:

- Amber: Power connected - initiating
- Steady green: Camera is operating in Continuous mode
- ✱ Flashing green. The camera is receiving external trigger



6.1.6. Auto-detect LVAL-sync / - a-sync accumulation

This function replaces the manual setting found in current JAI cameras. Whether accumulation is synchronous or a-synchronous in relationship to LVAL depends on the timing of the trigger input.

When a trigger is received while FVAL is high (during readout), the camera works in LVAL synchronous mode , preventing reset feed through in the video signal. There is a maximum jitter of one LVAL period from issuing a trigger and accumulation starts.

When trigger is received when FVAL is low, the camera works in LVAL a-synchronous mode (No delay) mode.

This applies to both Pre-Select (PS) trigger and Pulse Width (PW) trigger modes.

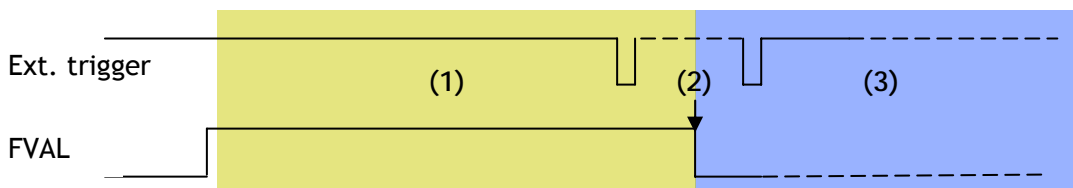

- (1) In this period camera executes trigger at next LVAL (prevents feed-through noise)
- (2) Avoid trigger at FVAL transition (+/- 1 LVAL period), as the function may randomly switch between "next LVAL" and "immediate".
- (3) In this period camera executes trigger immediately (no delay)

Fig. 9. Auto-detect LVAL sync /a-sync accumulation

6.1.7. Starting pixel - Bayer color mosaic

CB-200MCL is a color camera based on a CCD sensor with a Bayer RGB color mosaic. The color image reconstruction is done in the host PC. The Color sequence in the video signal differs from full scanning to partial scanning. The right hand drawing shows the color sequence at the image start. The start line number is shown from FVAL timing. The start pixel is offset 17 pixels from LVAL when DVAL rises.

Even lines starts with GBG.
Odd lines starts with RGR

See also chapter 6.3. Partial scan.

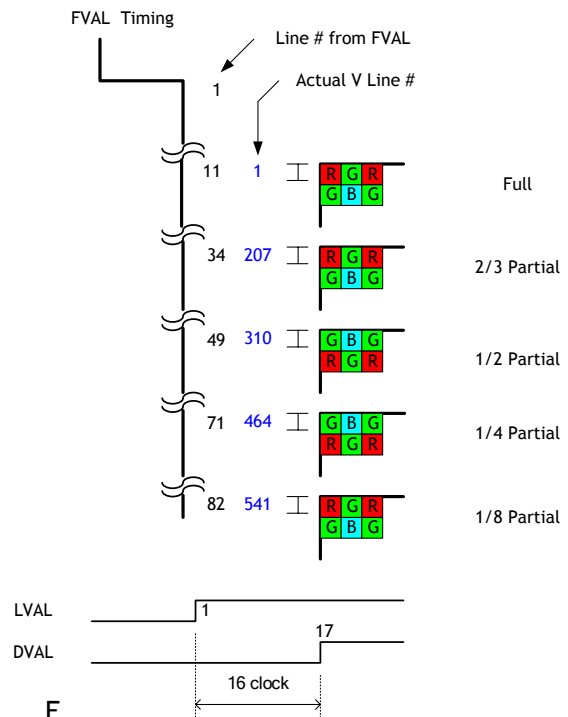

ig. 10. Bayer color mosaic

6.1.8. Vertical Binning

This function is only available for CM-200MCL camera.

Binning mode (Command VB) is a function where the signal charge from 2 adjacent (vertical) pixels are added together and read out as one pixel. Binning results in half vertical resolution and higher frame rate. By adding 2 pixels together, the sensitivity is doubled. The charge accumulated in 2 adjacent lines is added together in the horizontal CCD register. This is done by providing two pulses to the vertical CCD register for each line readout. Vertical binning can not be used together with the partial scanning.

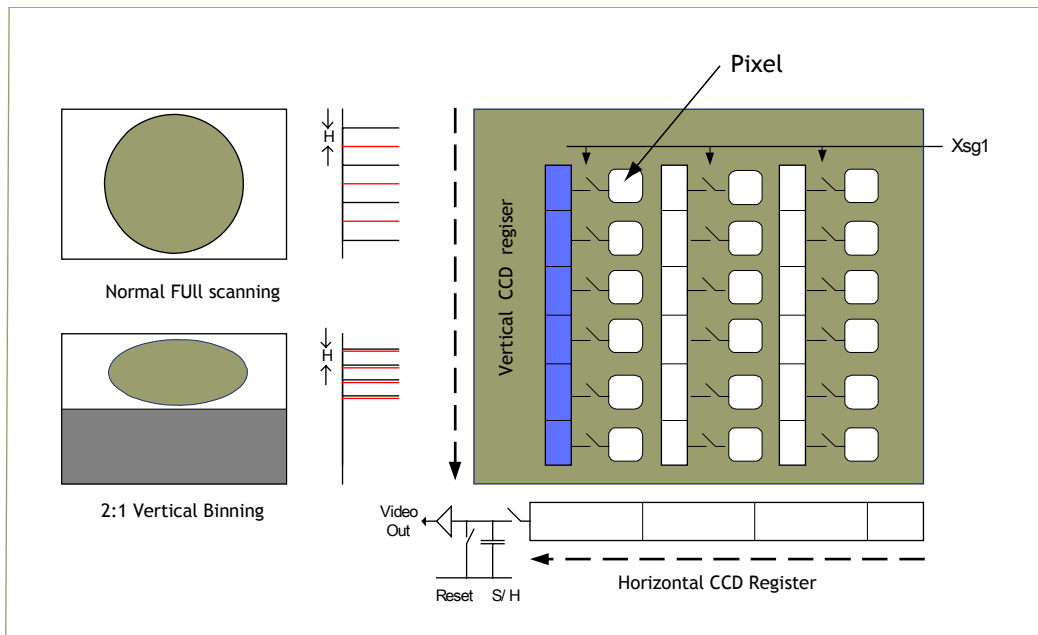

Fig.11 Vertical Binning

6.2. Sensor Layout and timing

6.2.1. CCD Sensor Layout

The CCD sensor layout with respect to pixels and lines used in the timing and video full frame read out is shown below.

For Bayer color sequence, refer to chapter 6.1.7.

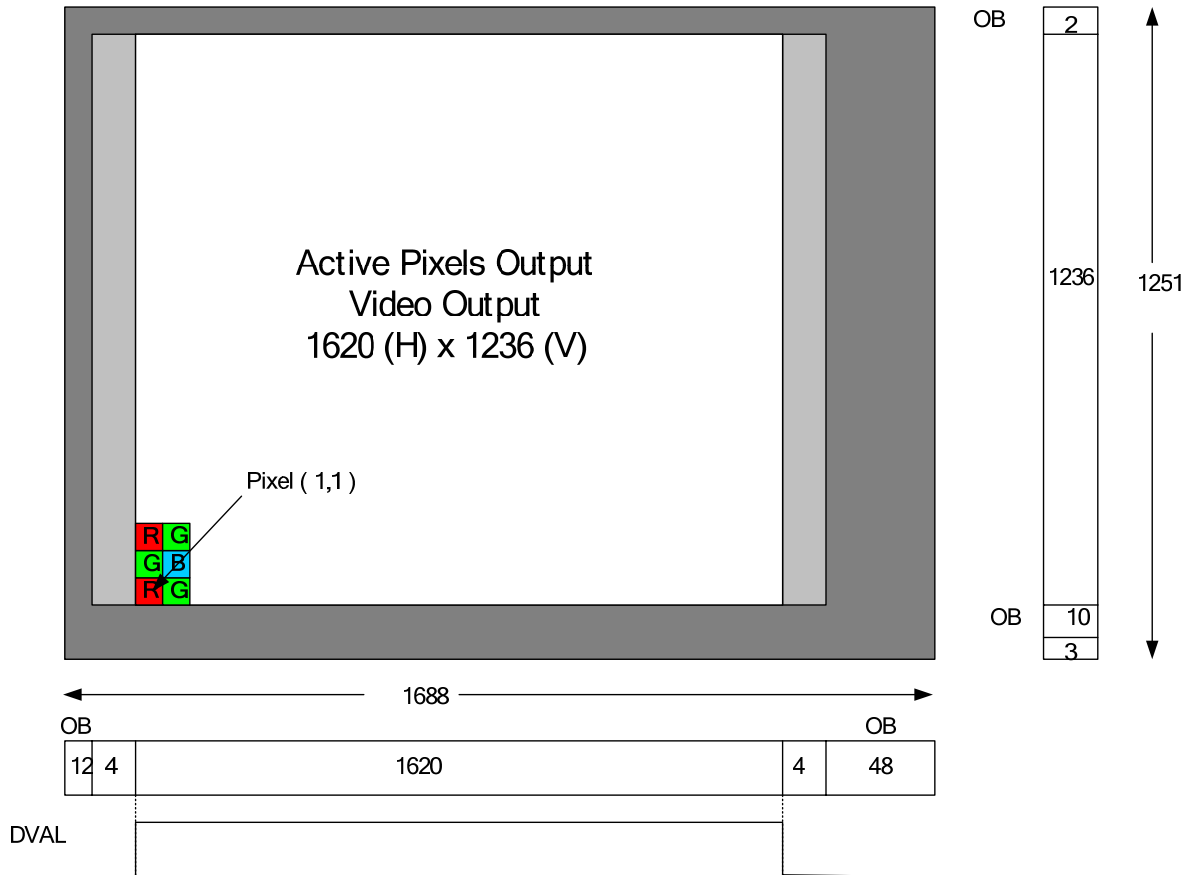

Fig. 12. CCD sensor layout

1 clock = 15.38 ns
1 line = 32 μ s

6.2.2. Horizontal timing

The LVAL period is shown for normal continuous mode.

Horizontal Video Timing Full Frame Read out / Partial Read Out
 1 LVAL 2080 clk = 32 μ s
 1 clk = 15.38 ns

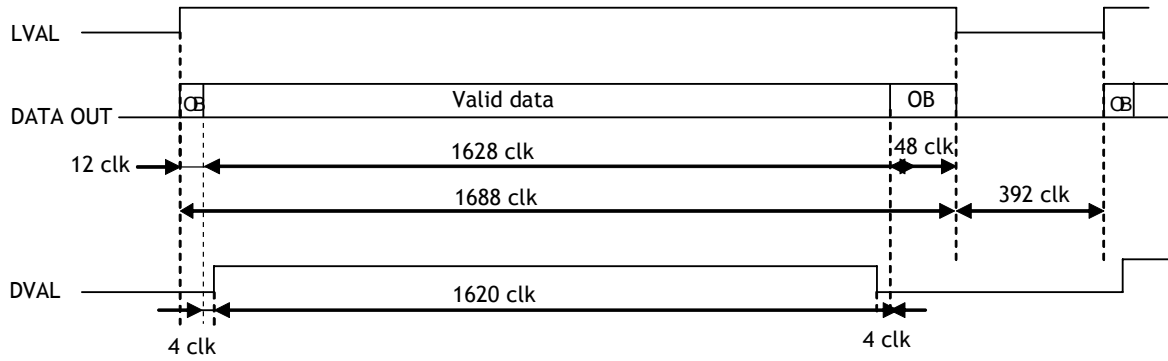

Fig. 13. Horizontal timing

6.2.3. Vertical timing

The FVAL period for continuous mode full scan is shown.

Vertical Video Timing Full Frame Read out
 Frame rate : 1251L 24.98fps

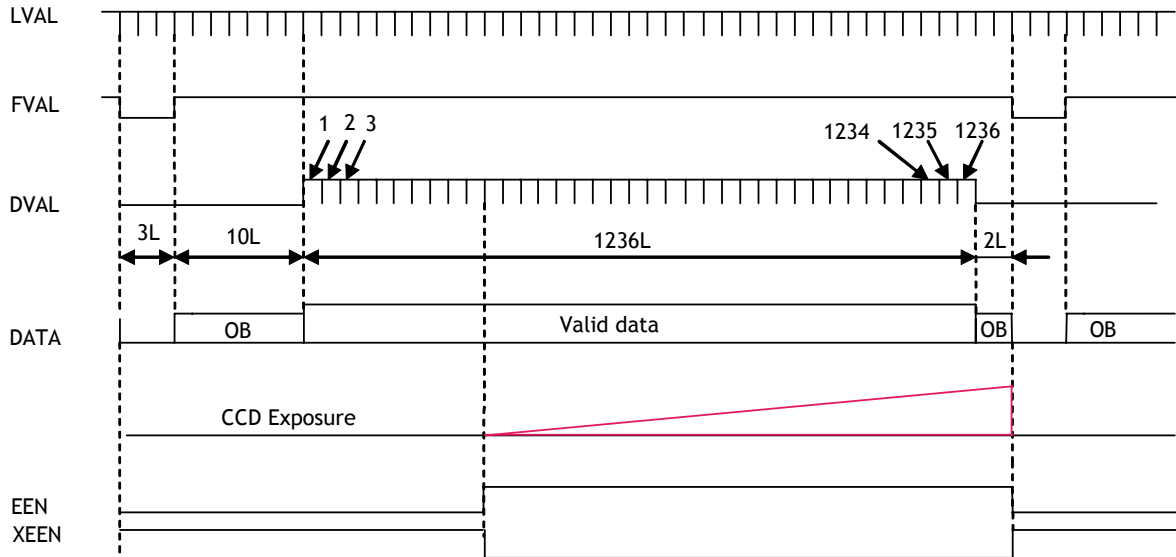
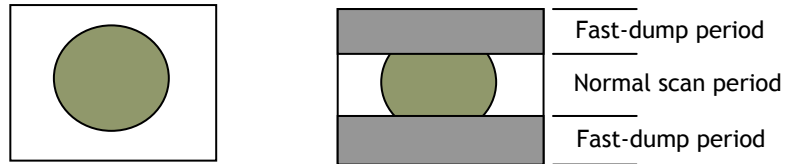

Fig. 14. Vertical timing for full scan

6.2.4. Partial Scanning

Partial scan allows higher frame rate by reading out a smaller center portion of the image. This is particularly useful when inspecting objects that do not fill the whole height of the image.



Vertical Timing

The below diagram and table provide vertical timing information for the fixed partial scan settings, 1/2, 1/4, 1/8 and 2/3.

Partial Frame Readout

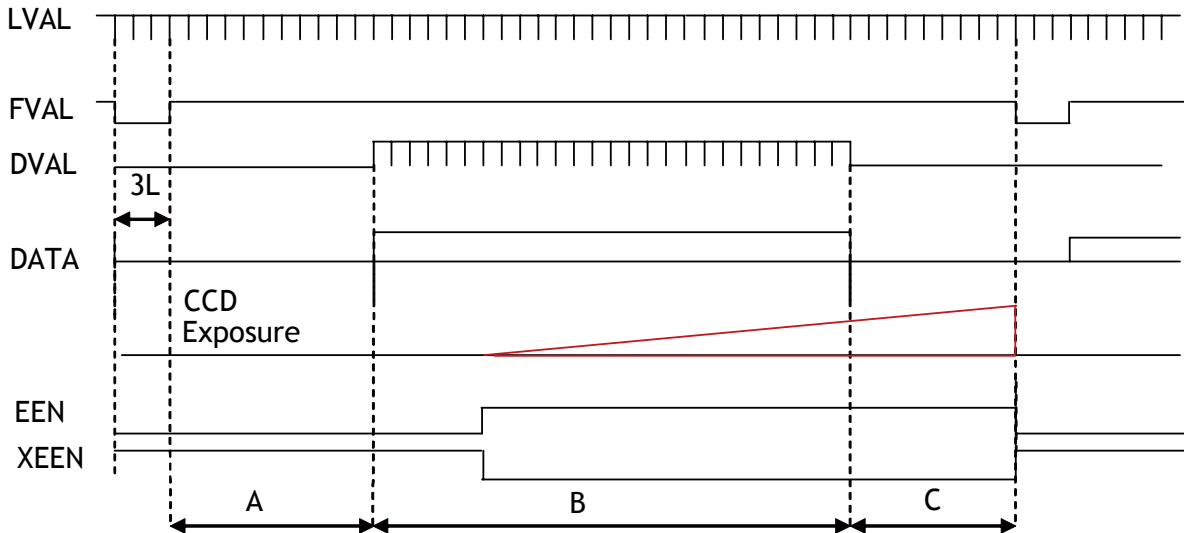

Values for vertical timing in partial scan continuous mode.

AREA	FVAL Low (L)	A (L)	B (L)		C (L)	Total line (L)	frame rate (L)
			Start line	End line			
1/2	3	46	618		45	712	43.89
			309	924			
1/4	3	68	310		67	448	69.75
			463	773			
1/8	3	79	156		78	316	98.89
			540	696			
2/3	3	31	824		30	888	35.19
			206	1030			

Remark! The color sequence for CB-200MCL differs in partial scan. Refer to chapter 6.1.7.

Fig. 15. Vertical timing for partial scanning

Horizontal Timing

The horizontal timing is the same as the full scanning.

Horizontal Video Timing Full Frame Read out / Partial Read Out
 1 LVAL 2080 clk = 32 μ s
 1 clk = 15.38 ns

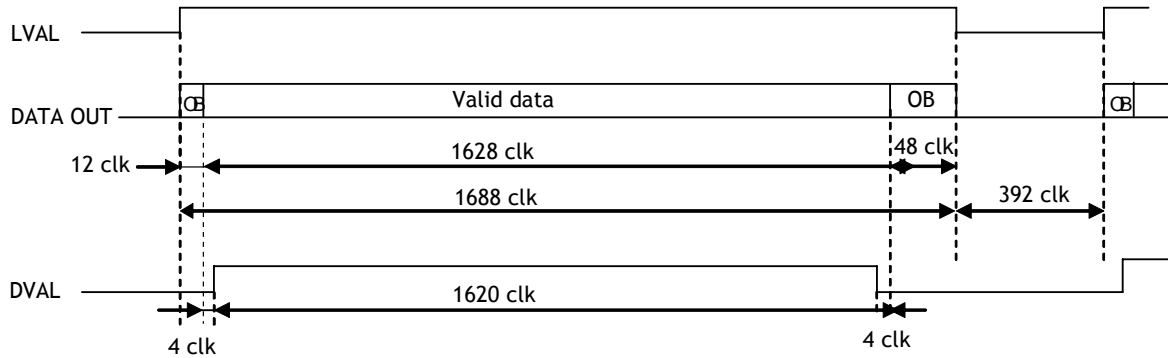

Fig. 16. Horizontal timing for partial scanning

6.2.5. Vertical Binning

Vertical binning combines charge from two adjacent lines, reducing the vertical resolution to half and at the same time increasing frame rate and sensitivity. By activating this function, the frame rate is increased to 44.49 fps.

This function is available only for CM-200MCL.

Important Note

Vertical Binning can not be used together with the Partial Scan.

Horizontal Timing

Horizontal Video Timing V Binning
 1 LVAL 2330 clk = 35.846 μ s
 1 clk = 15.38 ns

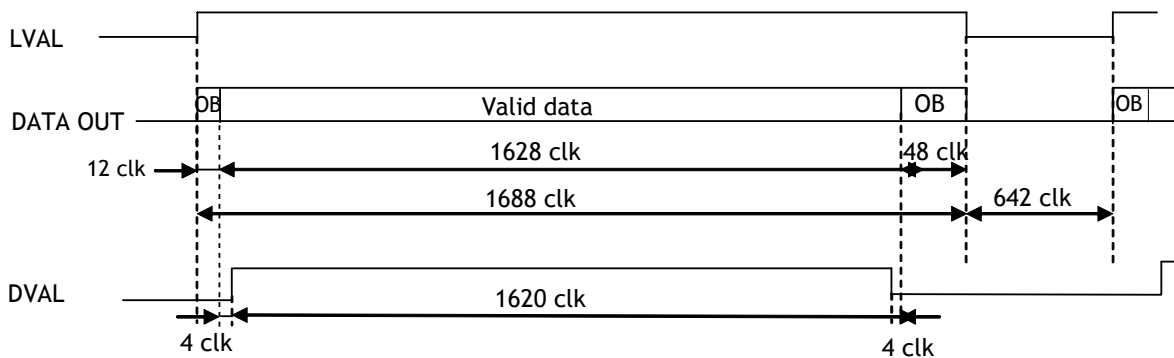

Fig.17. Horizontal Timing for Vertical Binning

Vertical timing

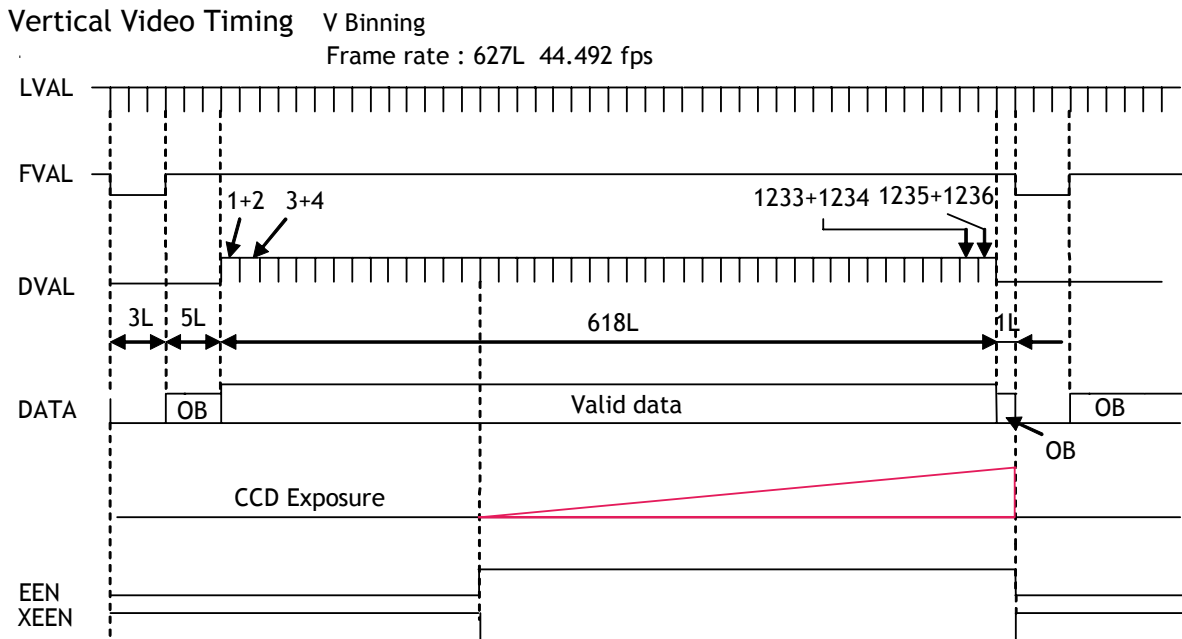

Fig.18. Vertical Timing for Vertical Binning

6.3. Operation Modes

This camera can operate in 3 primary modes.

1. *TR=0* Continuous Mode. Pre-selected exposure.
2. *TR=1* Pre-select Mode. Pre-selected exposure.
3. *TR=2* Pulse Width Control Mode. Pulse width controlled exposure.

6.3.1. Continuous operation

For applications not requiring asynchronous external trigger, but should run in continuous operation, this mode is used.

For timing details, refer to fig. 13 through fig. 18.

To use this mode:

Set function:	Trigger mode to "Continuous".	TR=0
	Scanning	SC=0 through 4
	V Binning	VB=0, VB=1
	Shutter mode pre-set or programmable	SM=0 SM=1
	Shutter speed	SH=0 to 9
	Programmable exp.	PE=2 to 1252
	Other functions and settings	

6.3.2. Edge Pre-select Trigger Mode

An external trigger pulse initiates the capture, and the exposure time (accumulation time) is defined by the SH or PE command.

The resulting video signal will start to be read out after the selected shutter time.

For timing details, refer to fig. 13 through fig. 18 and fig. 19 & 20.

To use this mode:

Set function:	Trigger mode to "Edge pre-select".	TR=1
	Scanning	SC=0 to 4
	V Binning	VB=0, 1
	Shutter mode to normal or programmable	SM=0, SM=1
	Shutter speed	SH=0 to 9
	Programmable exp.	PE=2 to 1252
	Other functions and settings	
Input:	Ext. trigger. Camera Link or 12 Hirose	TI=0, TI=1

Important notes on using this mode

1. The minimum trigger interval >1 LVAL.
2. Depending on the timing of the leading edge of the trigger pulse in relationship to FVAL, accumulation will be synchronous or a-synchronous in relationship to LVAL. See chapter 6.1.6. for details.

LVAL Sync mode timing

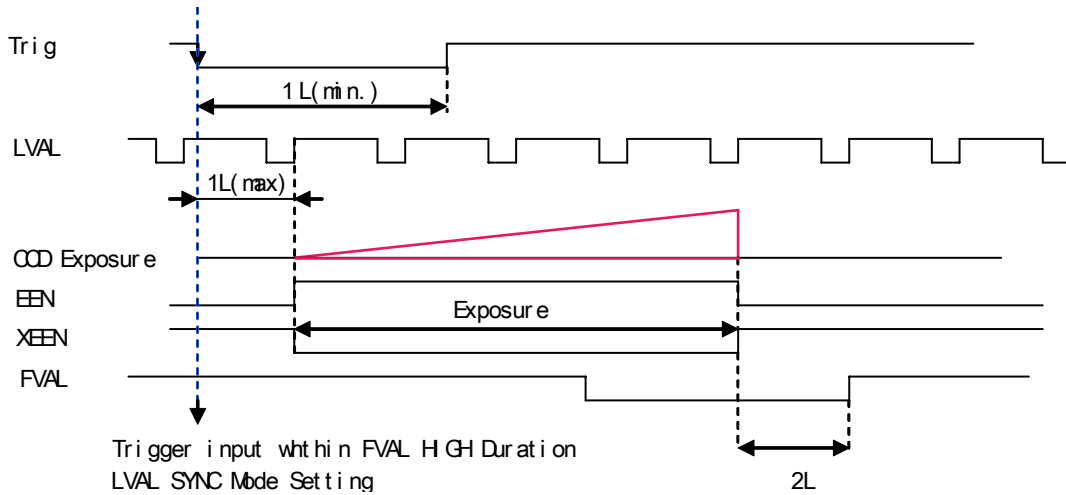

Fig. 19. Edge pre-select. LVAL synchronized.

LVAL a-SYNC mode timing

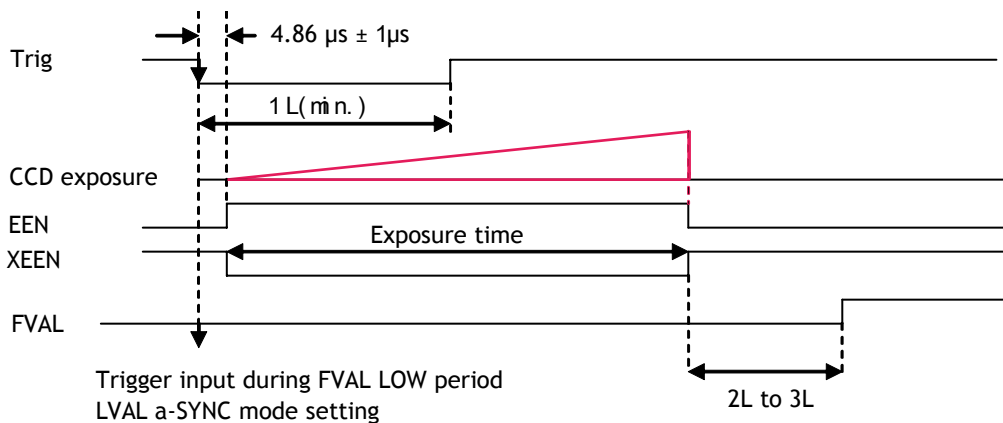

Fig.20. Edge Pre-select LVAL a-Synchronized

6.3.3. Pulse Width Control Trigger Mode

In this mode the accumulation time is equal the trigger pulse width. Here it is possible to have long time exposure. The maximum recommended time is <60 frames.

For timing details, refer to fig. 13 through fig. 18 and fig. 21 & 22.

To use this mode:

Set function:	Trigger mode to “Pulse width control”. Scanning V Binning Other functions and settings	TR=2 SC=0 to 4 VB=0, 1
Input:	Ext. trigger. Camera Link or 12 Hirose	TI=0, TI=1

Important notes on using this mode

1. The minimum trigger interval > 1 LVAL
2. Depending on the timing of the leading edge of the trigger pulse in relationship to FVAL, accumulation will be synchronous or a-synchronous in relationship to LVAL.
See chapter 6.1.6. for the details.

LVAL SYNC Mode timing

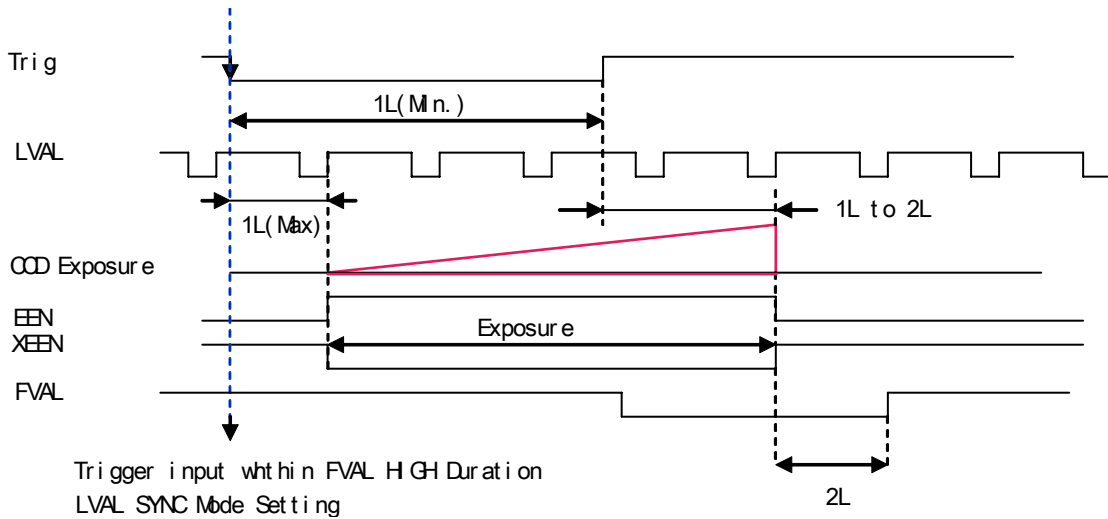

Fig. 21. Pulse width control. LVAL Synchronous.

LVAL a-SYNC mode timing

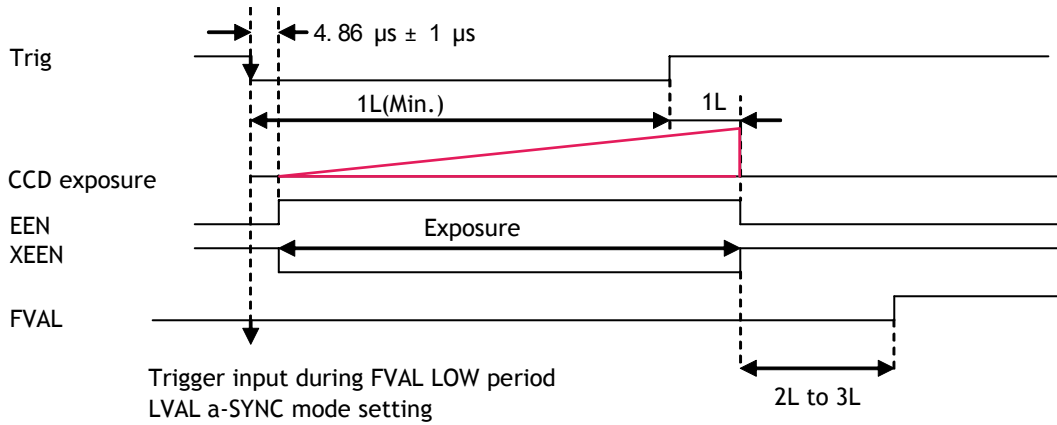

Fig.22. Pulse Width Control LVAL a-Synchronous

6.4. Mode and function matrix.

The following table shows which functions will work in the different modes for CM-200MCL / CB-200MCL.

Func.	Trigger Mode	Shutter		Partial scan	V Binning	Accumulation LVAL sync / a-sync	Iris Video out
		Pre-select	Programmable				
Continuos	TR=0	Yes	Yes	Yes	Yes	-	Yes
Pre-select	TR=1	Yes	Yes	Yes	Yes	Yes	-
Pulse Width	TR=2		-	Yes	Yes	Yes	-

Fig. 23. Mode and function matrix.

7. Configuring the Camera

7.1. CL-serial control

All configuration of the CM-200MCL / CB-200MCL camera is done the serial communication in the Camera Link connector. The camera can be set up from a PC running terminal emulator software, or using JAI's camera control software.

Below is the description of the ASCII based short command protocol.

Communication setting.

Baud Rate	9600 bps
Data Length	8 bit
Start Bit	1 bit
Stop Bit	1 bit
Parity	None
Xon/Xoff Control	None

Protocol.

Transmit setting to camera:

NN=[Parameter]<CR><LF> (NN is any kind of command. Capital or small letters.)

The camera answers:

COMPLETE<CR><LF>

To have all communication visible on the emulator screen, start with:

EB=1<CR><LF>

The camera answers:

COMPLETE<CR><LF>

Transmit request command to camera:

NN?<CR><LF> (NN is any kind of command.)

The camera answers:

NN=[Parameter]<CR><LF>

Transmit the following to have the camera actual setting:

ST?<CR><LF>

The camera answers:

A complete list of the current settings

Transmit the following to have a command list:

HP?<CR><LF>

The camera answers:

A list with all commands and possible settings

Invalid parameters send to camera: (99 is an invalid parameter)

SH=99<CR><LF>

The camera answers:

02 Bad Parameters!!<CR><LF>

To see firmware number.

VN?<CR><LF>

To see camera ID. It shows the manufacturing lot number.

ID?<CR><LF>

7.2. Setting functions

7.2.1. Bit allocation BA=0, BA=1

This command sets the output for either 8-bit or 10-bit.

7.2.2. Partial scan SC=0 through 4.

The CCD scanning format can be selected between full or partial scanning. With partial scanning only the vertical central part of the CCD sensor is read out with a higher frame rate. The partial scan is done by a fast dump read out of the lines in the vertical CCD register down to the top of the partial image. This central part of the image is read out with normal speed. The lines below the partial image are read out and dumped with a high speed.

Note: The color sequence for CB-200 MCL differs in partial scan modes. Refer to chapter 6.1.7.

7.2.3. Vertical binning VB=0, VB=1

This function is only for CM-200MCL camera.

With Vertical binning the pixel charge from 2 adjacent lines are added together in the horizontal CCD register. This done by providing two pulses to the vertical CCD register for each line readout.

Note : Vertical Binning can not be used together with the Partial scanning.

7.2.4. Shutter mode SM=0 and SM=1

With SM=0 this function selects the shutter from the 10 fixed steps (SH=0 through SH=9).
With SM=1 from programmable in 1251 steps (PE=2 through PE=1252).

7.2.5. Trigger input select TI=0, TI=1.

This function selects the trigger input to be through Camera Link (TI=0), or as TTL through the 12 pin Hirose connector (TI=1).

7.2.6. Trigger polarity. TP=0, TP=1.

The active trigger polarity is normal low (TP=0). It can be invert it to active high (TP=1).
6

7.2.7. Gain level GA= -84 through +336.

GA=0 is 0dB gain, which is normal working point. The range is from -3 dB to +12 dB.

7.2.8. Black level BL=0 through BL=1023.

Black level (or set-up level) will set the video level for black. Factory setting is 32 LSB for 10bit or 8 LSB for 8bit.

7.3. Save and Load Functions.

The following commands are for store and load camera settings in the camera EEPROM.

Load settings LD

CM-200 MCL / CB-200 MCL

This command will load previous stored settings to the camera. 3 user settings can be stored in the camera EEPROM. 1 factory setting is also stored in the camera. The settings stored in the last used user area is used as default settings at power up.

Save Settings SA

This command will store the actual camera settings to 1 of the 3 user area in the camera EEPROM.

EEPROM Area EA

If received, the camera will return the last used user area number.

7.4. CM-200MCL/CB-200MCL command list

	Command Name	Format	Parameter	Remarks
A - General settings and utility commands.				
1	Echo Back	EB=[Param.]<CR><LF> EB?<CR><LF>	0=Echo off 1=Echo on	Off at power up
2	Camera Status Request	ST?<CR><LF>		Actual setting
3	Online Help Request	HP?<CR><LF>		Command list
4	Firmware Version	VN?<CR><LF>		3 digits (e.g) 100 = Version 1.00
5	Camera ID Request	ID?<CR><LF>		max 10 characters
6	Model Name Request	MD?<CR><LF>		max 16 characters
7	User ID	UD=[Param.]<CR><LF> UD?<CR><LF>		User can save and load free text.(16 or less characters)
B - Shutter				
1	Shutter Mode	SM=[Param.]<CR><LF> SM?<CR><LF>	0=Preset Shutter 1=Programmable exposure	
2	Preset Shutter	SH=[Param.]<CR><LF> SH?<CR><LF>	0=Off, 1=1/60, 2=1/100, 3=1/250, 4=1/500, 5=1/1000, 6=1/2000, 7=1/4000, 8=1/8000, 9=1/10000	Available when SM=0.
3	Programmable Exposure	PE=[Param.]<CR><LF> PE?<CR><LF>	2 to 1252 (CM/CB-200)	Available when SM=1.
C - Trigger mode				
1	Trigger Mode	TR=[Param.]<CR><LF> TR?<CR><LF>	0=Normal (Continuous) 1=Pre-select 2=Pulse Width	
2	Trigger Polarity	TP=[Param.]<CR><LF>	0=Active Low	

	Command Name	Format	Parameter	Remarks
		TP?<CR><LF>	1=Active High	
3	Trigger Input	TI=[Param.]<CR><LF> TI? <CR><LF>	0=Camera Link 1=Hirose 12pin	
D -Image Format				
1	Bit Allocation	BA=[Param.]<CR><LF> BA?<CR><LF>	0=10bit 1=8bit	
2	Scan Format	SC=[Param.]<CR><LF> SC? <CR><LF>	0=Full Frame 1=2/3 Partial 2=1/2 Partial 3=1/4 Partial 4=1/8 Partial	
3	V-Binning	VB=[Param.]<CR><LF> VB?<CR><LF>	0=OFF 1=On	Only for CM-140MCL
E - Gain, Black and signal settings				
1	Gain Level	GA=[Param.]<CR><LF> GA?<CR><LF>	-84 to 336	
2	Black Level	BL=[Param.]<CR><LF> BL?<CR><LF>	0 to 1023	
F - Saving and loading data in EEPROM				
1	Load Settings (from Camera EEPROM)	LD=[Param.]<CR><LF>	0=Factory area 1=User 1 area 2=User 2 area 3=User 3 area	Latest used DATA AREA becomes default at next power up.
2	Save Settings (to Camera EEPROM)	SA=[Param.]<CR><LF>	1=User 1 area 2=User 2 area 3=User 3 area Note : parameter 0 is not allowed	
3	EEPROM Current Area No Request.	EA?<CR><LF>	0=Factory area 1=User 1 area 2=User 2 area 3=User 3 area	The camera return the latest used DATA AREA.

Note : Do not try to use commands not shown in this list.

8. Camera Control Tool for CM-200 MCL / CB-200 MCL

The camera control Tool for Windows 2000/XP can be downloaded from www.jai.com. The control tool contents a camera control program and a developer's kit for integrating the control tool in your own software. For the integrator and experienced user, the Camera Control Tool is much more than a program with a window interface. It also provides an easy and efficient ActiveX interface built for MS Windows 2000/XP. The OCX interface has the ability to connect to the camera using the serial interface of the PC by reading and writing properties for the camera. This integration requires simple programming skills within Visual Basic, Visual C++ or similar languages in a Microsoft Windows environment.

8.1. Camera Control Tool Interface

The Camera Control Tool Software is based on a main Tool Bar and a number of associated Tool Windows. Each button in the Tool Bar pops up a separate Tool Window when pressed. The layout of the program can be adjusted by arranging the windows the way it is preferred. The program will store this information and recreate this layout, when the program is restarted. All Camera Control Tools have a Communication Window and an About Window. The other window(s) contains camera control commands.

8.1.1. Camera Control Tool Bar

This is a Camera Control Tool Bar and when the button of each window, each control GUI can be initiated.

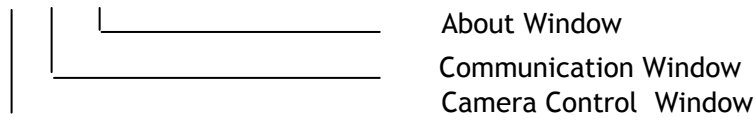
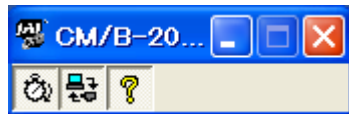

8.2. The About Window

The about window contains information about the version of the program, Internet connection to JAI A/S and access to the help documents.

The drop-down List box labelled " Help File" will list all files, which have the extension .pdf and that are found in the program (default) folder.

C:\Program Files\JAI A-S\control tool name"

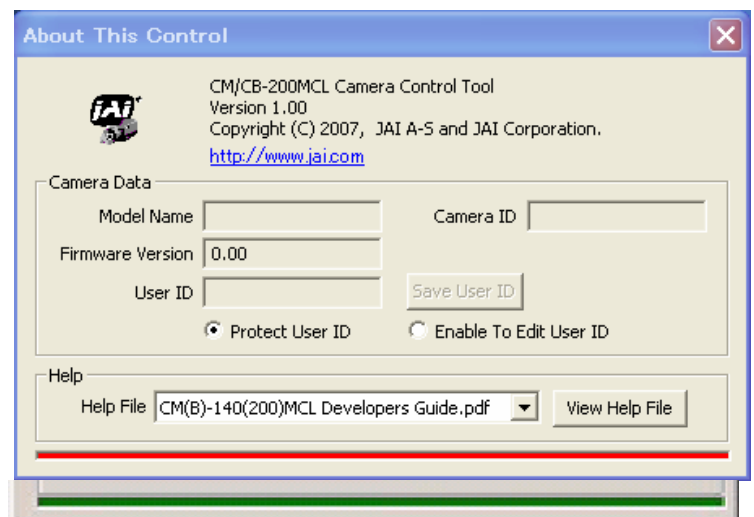

It is possible to download updated operation manuals from the "downloads" section at the JAI website:

<http://www.jai.com>

An updated manual can be saved in the folder address mentioned above and it will automatically be included in the list of help files.

At the bottom of the windows (all windows but the Communication Window is an indicator bar. The bar is green when the Camera Control Tool is connected to a camera and the camera is turned on. The bar is red when the Camera Control Tool is not connected to a camera or when the camera is turned off.

8.3. Communication Window

The Communication Window is used to connect the Camera Control Tool with the JAI camera.

Camera Link communication:

The 'CL Manufacturer/COM-ports' list box also contains DLL file names (or frame grabber names) for all Camera Link frame grabbers that are installed in the pc. This is done by using a DLL file called "clserial.dll" to upload all frame grabber DLLs that are found in the pc.

Just select the option for the frame grabber that is installed in the pc.

Auto search

Click the auto button to search for a camera on communication port 1 to 16. The camera control program automatically sends camera request on every communication port. The user is prompted to use a communication port if a camera answers the request.

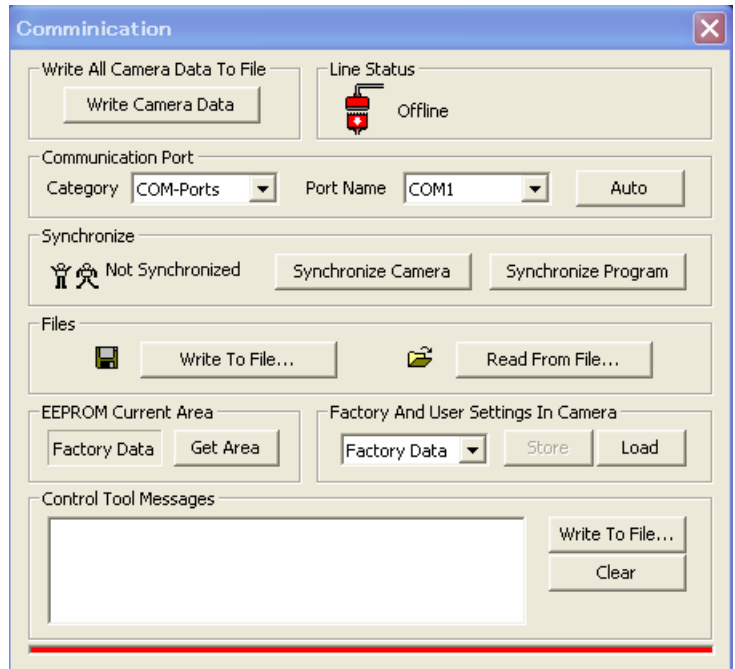

Off/On-line mode

The Camera Control Tool Application can run Offline (without a camera attached) and all functions are fully functional in offline mode.

Off line mode is indicated in The Communication Window, where a status field with graphic and text indicates the on/off-line status.

Changing the selected communication port (from the communication window) changes the online/off-line status. If a camera is found on the selected communication port the application runs online otherwise offline.



Changing the settings in the application will automatically update the camera settings when the application is online.

If the application loses connection with the camera it will automatically go to offline mode and it is indicated in the communication window.

Synchronize program and camera

The Camera Control software has the ability to synchronize either the camera or the program. Click Synchronize camera to write all settings from the program to the camera or click the Synchronize program to load all settings from the camera to the program.

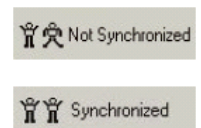

Files

When clicking the Write to File or Read from File button, the user is prompted for a file using a standard file dialog. New files are created if they do not already exist.

Files for camera settings have the extension cam. Information about the communication port is not stored in the files. All settings are automatically sent to the camera when a file has been loaded (if the camera is online).

Factory and User Settings

Use the Store button to store the current camera settings into the user settings area in EEPROM. Current camera settings are not saved when the camera is turned off. To save current camera settings you have to save them on the available user areas.

Use the Load button to restore previously saved camera settings from either the Factory or the User EEPROM area.

Write All Camera Data to File.

Click the “Write Camera Data” button to save all camera settings into a text file. The information that can be saved is:

Model Name, Camera ID, User ID, Firmware Version, Current Settings, Factory Settings and the available User Areas.

The file is formatted as shown in the picture below:



EEPROM Current Area.

Click the ‘Get Area’ button to read the power up settings area number.

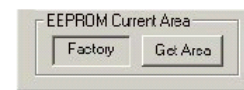

8.4. Camera Control Window

The Camera Control Window contains the fundamental camera setting functions. It is possible to set the shutter mode, Trigger mode, scan format, gain control and black setting.

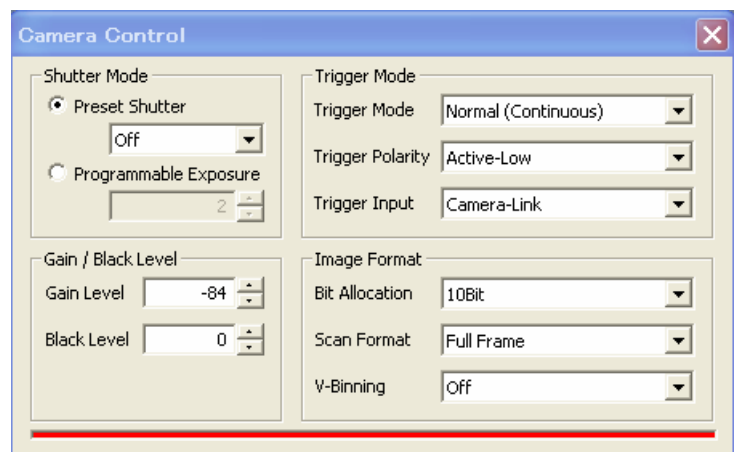

8.5. Using the Camera Control Tool

Here is some practical information about the Camera Control Tool:

1. The Camera Control Tool bar is always on top of other windows.
2. When you minimize the Camera Control Tool bar all open windows will close.
3. It is possible to work with the Camera Control Tool when the camera is online and when the camera is offline.
4. The newer JAI cameras always start up with the last used user area (but for some old models it will start up with the last saved user area.)
5. The Camera Control Tool saves the last used settings (not the user area), which don't have to be the same as for the last saved user area.
6. The setup file 'CameraName.ini' stores all information about camera settings. When the program is started the last settings for the program are loaded from the file 'CameraName.ini'
7. When you turn on the camera and the Camera Control Tool, it is possible that the

-
- Camera Control Tool does not show the actual camera settings (see 4. and 5.).
- a. To obtain the camera settings click “Synchronize Program”.
 - b. To send the settings that are saved in the Camera Control Tool (last used settings) to the camera click “Synchronize Camera”.
 - c. To see which area the camera has started up in click “Get Area”.

9. External Appearance and Dimensions

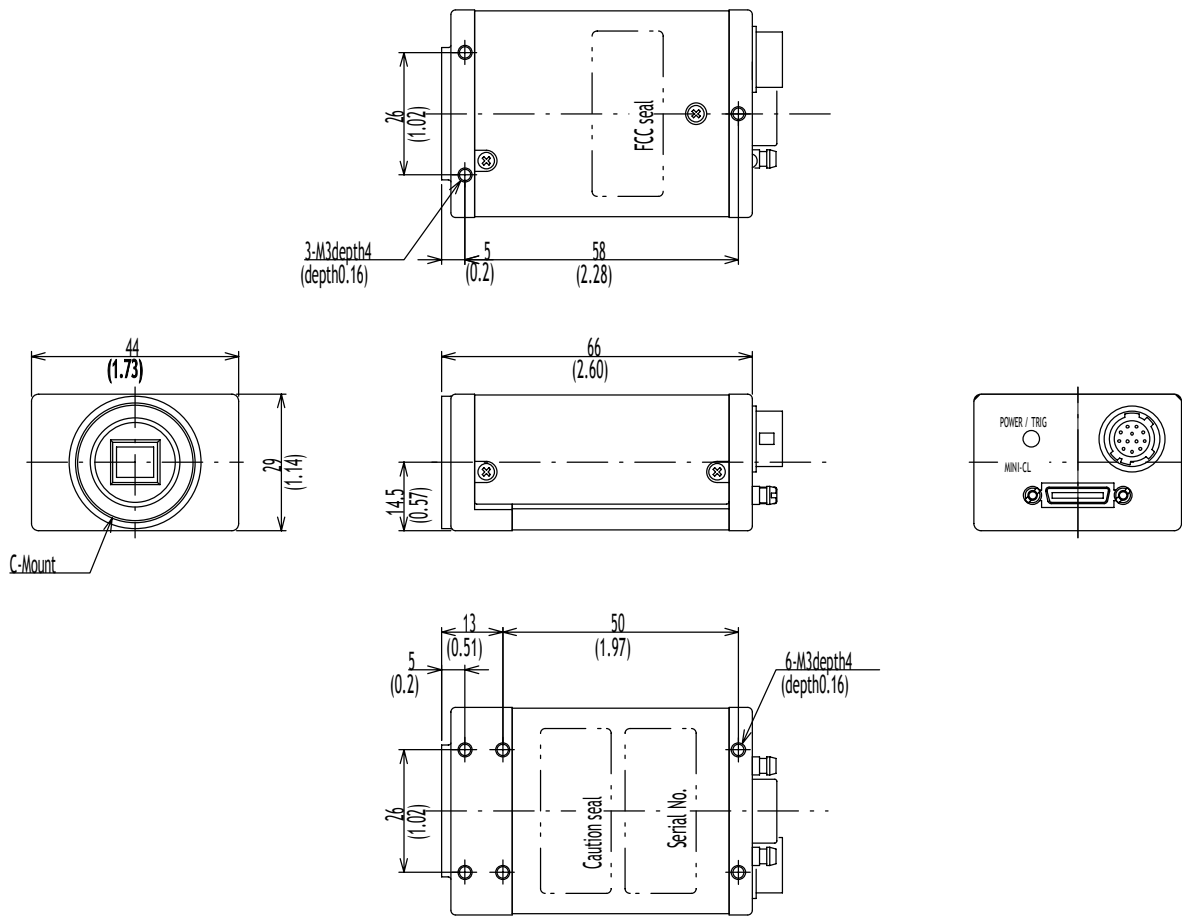

Fig. 24. Outline.

Note: Cameras with the PoCL (Power-over-CL) option do not have the 12-pin connector. All other parts are identical.

10. Specifications

10.1. Spectral response

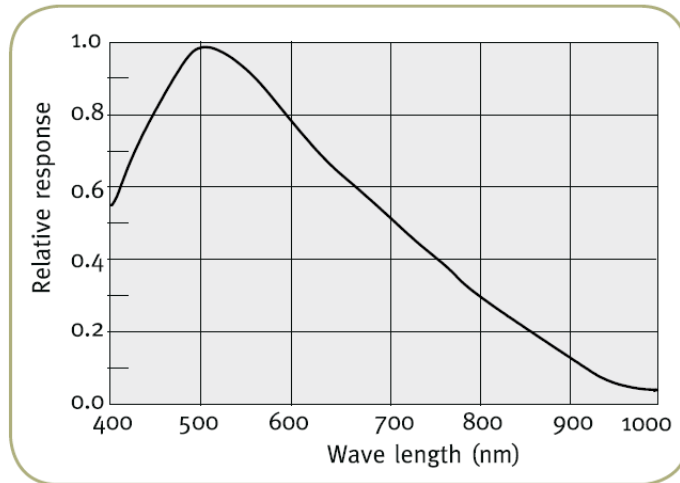

Fig. 25. Spectral response for CM-200MCL

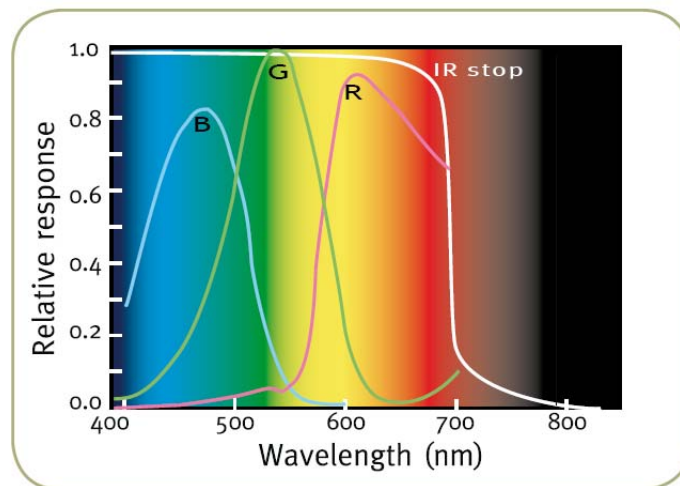

Fig.26. Spectral response for CB-200MCL

CM-200 MCL / CB-200 MCL

10.2. Specification table

Specifications	CM-200MCL	CB-200MCL
Scanning system	Progressive scan	
Frame rate full frame	24.98 frames/sec. Progressive (1251 lines/frame)	
Pixel clock	65 MHz	
Line frequency	31.25kHz (2080 pixels clock/line)	
CCD sensor	1/1.8". Monochrome ICX274AL	1/1.8" Color ICX274AQ
Sensing area	7.13 (h) x 5.44 (v) mm	
Cell size	4.4 (h) x 4.4(v) μ m	
Active pixels	1620 (h) x 1236 (v)	
Pixels in video output. Full 2/3 partial 1/2 partial 1/4 partial 1/8 partial	1620 (h) x 1236 (v) 24.98 fps. H = 31.25 kHz 1620(h) x 888 (v) 35.19 fps H= 31.25 kHz 1620 (h) x 712(v) 43.89 fps. H = 31.25 kHz 1620 (h) x 448 (v) 69.75 fps. H = 31.25 kHz 1620 (h) x 316 (v) 98.89 fps. H = 31.25 kHz	
Sensitivity on sensor (minimum)	0.25 Lux (Max. gain, Shutter OFF,50% video)	0.8 Lux (Max. gain, Shutter OFF,50% Green, w/IR cut filter)
S/N ratio	More than 50 dB (0dB gain)	
Digital Video output.	8 or 10 bit in Camera Link	8 or 10 bit raw Bayer video in Camera Link
Iris video output. Analogue	0.7 Vpp	
Gain	Manual -3 to +12 dB	
Gamma	1.0	
Synchronization	Int. X-tal., External trigger	
Trigger input. TTL Camera Link	4 V \pm 2 V. TTL Via Camera Link	
EEN output	4 V from 75 Ω source	
Trigger modes	Pre-Select and Pulse Width	
Accumulation	LVAL synchronous or a-synchronous automatic selection	
Preset Shutter speed	9 fixed steps 1/60 to 1/10,000 second	
Programmable exposure	2 L to 1250 L (64 μ s to 40.032ms)	
Pulse width control	1 L to 48 frames.	
Readout modes	Full, Partial scan.(2/3,1/2, 1/4, 1/8.) V Binning	Full, Partial scan.(2/3,1/2, 1/4, 1/8.)
Control interface	Camera Link serial	
Functions controlled by RS 232C	Shutter, Trigger, Scanning, Read out, Polarity, Black level, Gain,	
Operating temperature	-5°C to +45°C	
Humidity	20 - 90% non-condensing	
Storage temp/humidity	-25°C to +60°C/20% to 90% non-condensing	
Vibration	10G (20Hz to 200Hz, XYZ)	
Shock	70G	
EMC	CE (EN61000-6-2 and EN61000-6-3), FCC part 15 class B	
Power	12V DC \pm 10%. <0.27A (Normal Operation)	
Lens mount	C-mount (Flange back 17.526 mm -0.05mm) Image centre \pm 0.1mm from C-mount centre	
Dimensions	44 x 29 x 66 mm (HxWxD)	
Weight	115 g	120 g

Note: Above specifications are subject to change without notice

11. Appendix

11.1. Precautions

Personnel not trained in dealing with similar electronic devices should not service this camera. The camera contains components sensitive to electrostatic discharge. The handling of these devices should follow the requirements of electrostatic sensitive components.

Do not attempt to disassemble this camera.

Do not expose this camera to rain or moisture.

Do not face this camera towards the sun, extreme bright light or light reflecting objects.

When this camera is not in use, put the supplied lens cap on the lens mount.

Handle this camera with the maximum care.

Operate this camera only from the type of power source indicated on the camera.

Power off the camera during any modification such as changes of jumper and switch setting.

11.2. Typical Sensor Characteristics

The following effects may be observed on the video monitor screen. They do not indicate any fault of the camera, but do associate with typical sensor characteristics.

V. Aliasing

When the CCD camera captures stripes, straight lines or similar sharp patterns, jagged image on the monitor may appear.

Blemishes

Some pixel defects can occur, but this does not have an effect on the practical operation.

Cameras are shipped in the condition that CCD spots are not visible.

In general, it is said that photo diodes of CCD sensor might be damaged by influence of cosmic ray and as a result, CCD sensor will have spots.

Please pay attention so that camera might not be influenced by cosmic ray on storage and transportation.

We also recommend to use sea shipment instead of air flight due to strong influence of cosmic ray to camera.

Patterned Noise

When the sensor captures a dark object at high temperature or is used for long time integration, fixed pattern noise may appear on the video monitor screen.

Caution when mounting a lens on the camera

When mounting a lens on the camera dust particles in the air may settle on the surface of the lens or the image sensor of the camera. It is therefore important to keep the protective caps on the lens and on the camera until the lens is mounted. Point the lens mount of the camera downward to prevent dust particles from landing on the optical surfaces of the camera. This work should be done in a dust free environment. Do not touch any of the optical surfaces of the camera or the lens.

Exportation

When exporting this product, please follow the export regulation of your own country.

11.3. References

1. This manual can for CM/CB-200MCL can be downloaded from www.jai.com
2. Datasheet for CM/CB-200MCL can be downloaded from www.jai.com
3. Camera control software can be downloaded from www.jai.com
4. Specifications for the CCD sensor Sony ICX274AL and ICX274AQ can be found on www.jai.com

Index

Bayer mosaic color, 3, 7
Binning, 1, 10, 15, 22
Binning mode, 10
Bit allocation, 1, 22
Black level, 1, 22, 31
Blemishes, 32
Camera Control Tool, 1, 3, 25, 26, 27, 28
Camera Link, 1, 4, 5, 6, 7, 9, 17, 18, 21, 22, 24, 26, 31
Camera Link connector, 6
CCD sensor, 4
Continuous operation, 3, 7, 16
External trigger, 3, 6, 8, 9, 16
Gain, 6, 9, 22, 27, 31
Gamma, 31
Hirose, 5, 6, 8, 9, 17, 18, 22, 24
Lens mount, 4, 31
Mini-CL connector, 5
Partial scanning, 7, 10, 14, 15, 22
Pixels in video output, 31
PoCL, 3, 6
Preset shutter, 8
Programmable exposure, 8
Progressive scan, 3, 7
Scanning format, 22
Spectral response, 30
Synchronization, 31
Trigger input, 1, 4, 6, 22, 31
Trigger polarity, 6, 22
Vertical binning, 3, 7, 8
XEEN, 1, 5, 6

12. User's Record

Camera type: CM-200 MCL / CB-200 MCL
Revision:
Serial No.
Firmware version.

For camera revision history, please contact your local JAI distributor.

User's Mode Settings.

User's Modifications.



DECLARATION OF CONFORMITY
AS DEFINED BY THE COUNCIL DIRECTIVE
89/336/EEC
EMC (ELECTROMAGNETIC COMPABILITY)
WE HEREWITH DECLARE THAT THIS PRODUCT
COMPLIES WITH THE FOLOWING PROVISIONS APPLYING TO IT.
EN61000-6-2
EN61000-6-3

Company and product names mentioned in this manual are trademarks or registered trademarks of their respective owners. JAI A-S cannot be held responsible for any technical or typographical errors and reserves the right to make changes to products and documentation without prior notification.

Europe, Middle East & Africa

*Phone +45 4457 8888
Fax +45 4491 8880*

Asia Pacific

*Phone +81 45 440 0154
Fax +81 45 440 0166*

Americas

*Phone (toll-free) +1 800 445 5444
Phone +1 408 383 0300*

Visit our web site at www.jai.com



See the possibilities

Supplement

The following statement is related to the regulation on “ Measures for the Administration of the control of Pollution by Electronic Information Products ” , known as “ China RoHS ” . The table shows contained Hazardous Substances in this camera.

 mark shows that the environment-friendly use period of contained Hazardous Substances is 15 years.

重要注意事项

有毒，有害物质或元素名称及含量表

根据中华人民共和国信息产业部『电子信息产品污染控制管理办法』，本产品《有毒，有害物质或元素名称及含量表》如下。

部件名称	有毒有害物质或元素					
	铅 (Pb)	汞 (Hg)	镉 (Cd)	六价铬 (Cr(VI))	多溴联苯 (PPB)	多溴二苯醚 (PBDE)
螺丝固定座	×	○	○	○	○	○
.....
○：表示该有毒有害物质在该部件所有均质材料中的含量均在SJ/T11363-2006规定的限量要求以下。 ×：表示该有毒有害物质至少在该部件的某一均质材料中的含量超出SJ/T11363-2006规定的限量要求。 （企业可在此处、根据实际情况对上表中打“×”的技术原因进行进一步说明。）						



环保使用期限

电子信息产品中含有的有毒有害物质或元素在正常使用的条件下不会发生外泄或突变、电子信息产品用户使用该电子信息产品不会对环境造成严重污染或对基人身、财产造成严重损害的期限。

数字「15」为期限15年。

Supplement

The following statement is related to the regulation on “ Measures for the Administration of the control of Pollution by Electronic Information Products ” , known as “ China RoHS ” . The table shows contained Hazardous Substances in this camera.

 mark shows that the environment-friendly use period of contained Hazardous Substances is 15 years.

重要注意事项

有毒，有害物质或元素名称及含量表

根据中华人民共和国信息产业部『电子信息产品污染控制管理办法』，本产品《有毒，有害物质或元素名称及含量表》如下。

部件名称	有毒有害物质或元素					
	铅 (Pb)	汞 (Hg)	镉 (Cd)	六价铬 (Cr(VI))	多溴联苯 (PPB)	多溴二苯醚 (PBDE)
螺丝固定座	×	○	○	○	○	○
光学滤色镜	×	○	×	○	○	○
.....

○：表示该有毒有害物质在该部件所有均质材料中的含量均在SJ/T11363-2006规定的限量要求以下。
 ×：表示该有毒有害物质至少在该部件的某一均质材料中的含量超出SJ/T11363-2006规定的限量要求。
 (企业可在此处、根据实际情况对上表中打“×”的技术原因进行进一步说明。)



环保使用期限

电子信息产品中含有的有毒有害物质或元素在正常使用的条件下不会发生外泄或突变、电子信息产品用户使用该电子信息产品不会对环境造成严重污染或对基人身、财产造成严重损害的期限。

数字「15」为期限15年。