



See the possibilities

User's Manual

CM-030GE

CB-030GE

*Digital Monochrome / Color
Progressive Scan GigE Vision Camera*

Document Version: 1.0

Camera Revision: A

Table of Contents

1.	General.....	- 3 -
2.	Camera nomenclature	- 3 -
3.	Main Features	- 4 -
4.	Locations and Functions	- 5 -
5.	Pin Assignment	- 6 -
5.1	12-pin Multi-connector (DC-in/GPIO/Iris Video).....	- 6 -
5.2	Digital Output Connector for Gigabit Ethernet	- 6 -
6.	GPIO (Inputs and outputs).....	- 7 -
6.1	Overview.....	- 7 -
6.1.1	LUT (Look Up Table)	- 7 -
6.1.2	12-bit Counter.....	- 8 -
6.1.3	Pulse Generators (0 to 3).....	- 8 -
6.2	Opto-isolated Inputs/Outputs	- 8 -
6.2.1	Recommended External Input circuit diagram for customer	- 8 -
6.2.2	Recommended External Output circuit diagram for customer	- 9 -
6.2.3	Optical Interface Specifications	- 9 -
6.3	Inputs and outputs table	- 10 -
6.4	Configuring the GPIO module (register settings).....	- 10 -
6.4.1	Input/Output Signal Selector	- 10 -
6.4.2	12-bit counter	- 11 -
6.4.3	Pulse generators (20-bit x 4).....	- 11 -
6.5	GPIO programming examples.....	- 13 -
6.5.1	GPIO Plus PWC shutter	- 13 -
6.5.2	Internal Trigger Generator	- 14 -
7.	GigE Vision Streaming Protocol (GVSP).....	- 15 -
7.1	Digital Video Output (Bit Allocation).....	- 15 -
7.2	Bit Allocation (Pixel Format / Pixel Type) - CM-030GE	- 15 -
7.2.1	GVSP_PIX_MONO8 (8bit)	- 15 -
7.2.2	GVSP_PIX_MONO10 (10bit)	- 15 -
7.2.3	GVSP_PIX_MONO10_PACKED (10 bit)	- 16 -
7.3	Bit Allocation (Pixel Format / Pixel Type) - CB-030GE.....	- 16 -
7.3.1	GVSP_PIX_BAYRG8 “BayreRG8 “	- 16 -
7.3.2	GVSP_PIX_BAYRG10 “Bayer RG10”	- 16 -
7.3.3	GVSP_PIX_BAYGB8 “BayerGB8”	- 16 -
7.3.4	GVSP_PIX_BAYGB10 “BayerGB10”	- 17 -
8.	Functions and Operations	- 18 -
8.1	GigE Vision Standard Interface.....	- 18 -
8.2	Recommended Network Configurations	- 18 -
8.2.1	Verified Network Interface Cards (NICs)	- 18 -
8.2.2	Video data rate (network bandwidth).....	- 19 -
8.2.3	How to set Jumbo Frame (in Windows™ XP environments).....	- 19 -
8.2.4	Packet delay.....	- 21 -
8.3	Basic functions.....	- 21 -
8.3.1	Vertical Binning (CM-030GE only).	- 22 -
8.3.2	CB-030GE. Bayer filter	- 22 -
8.3.3	Electronic Shutter	- 23 -
8.3.4	Auto Iris Lens video output (12-pin Hirose connector).....	- 24 -
8.3.5	Auto-detect LVAL-sync / a-sync. accumulation.....	- 24 -
8.3.6	Rear panel indicator.....	- 25 -
8.4	Sensor Layout and timing	- 25 -
8.4.1	CCD Sensor Layout.....	- 25 -
8.4.2	Horizontal timing	- 26 -
8.4.3	Vertical timing	- 26 -
8.4.4	Partial Scanning.....	- 27 -
8.4.5	Vertical binning	- 28 -
8.5	Operation Modes.....	- 29 -



8.5.1	Continuous operation	- 29 -
8.5.2	Pre-select Trigger Mode	- 30 -
8.5.3	Pulse Width trigger mode	- 31 -
8.5.4	Sequential Trigger Mode (Pre-Select trigger)	- 33 -
8.5.5	Delayed Readout Mode (Pre-Select)	- 34 -
8.5.6	Optical Black transfer mode	- 35 -
8.6	Operation Mode and Functions matrix	- 36 -
9.	Register Map.....	- 37 -
10.	External Appearance and Dimensions	- 47 -
11.	Specifications	- 48 -
11.1	Spectral response	- 48 -
11.2	Specification table.....	- 49 -
12.	Appendix	- 51 -
	Precautions	- 51 -
	Typical Sensor Characteristics.....	- 51 -
	References	- 52 -
13.	User's Record	- 54 -

1. General

This manual covers the digital monochrome progressive scan camera CM-030GE and color progressive scan camera CB-030GE

The CM-030GE/CB-030GE is a new addition to JAI GigE Vision compliant camera series. Both the monochrome version CM-030GE and the color version CB-030GE provide a frame rate of 90.5 frames/second at full resolution. Using vertical binning (CM-030GE only) and partial scan provides higher frame rates.

The 1/3" CCD with square pixels offers a superb image quality. The high-speed shutter function and asynchronous random trigger mode allows the camera to capture high quality images of fast moving objects.

The color version CB-030GE, based on CCD sensor with primary RGB Bayer mosaic filter, outputs raw Bayer images. Host-based color interpolation is required to display or save color images.

The CM-030GE/CB-030GE also complies with the GenICam standards, as it has an internal XML file that is used to describe the functions/features of the camera. For further information on GenICam please go to www.emva.org.

As an application programming interface, JAI provides an SDK (Software Development Kit). This SDK includes software documentation, register information, code examples and objects such as Transport layer and Device driver (High Performance Filter Driver and Standard Windows Stack). Filter Driver, JAI Control tool, software documentation and code examples. The JAI SDK can be downloaded from www.jai.com.

The latest version of this manual can be downloaded from www.jai.com

For camera revision history, please contact your local JAI distributor.

2. Camera nomenclature

The standard camera composition consists of the camera main body and C-mount protection cap.

The camera is available in the following versions:

CM-030GE

Where C stands for "Compact" family, M stands for "Monochrome", 030 represents the resolution "300 thousand pixel" and GE stands for "GigE Vision" interface

CB-030GE

Where C stands for "Compact" family, B stands for "Bayer mosaic color", 030 represents the resolution "300 thousand pixel" and GE stands for "GigE Vision" interface

3. Main Features

- Member of Compact series, covering VGA to UXGA resolution
- 656 (h) x 494 (v) 7.4 μm square pixels
- 1/3" progressive scan - Monochrome and Bayer mosaic color versions
- High frame rate of 90.5 frames/second with full resolution in continuous operation
- 90 frames/second with external trigger and full resolution
- Increased frame rate with vertical binning (CM-030GE only) and partial scan
- Exposure time from 21.6 μs to 2 sec. using Pulse Width Control trigger mode
- Programmable exposure from 43.2 μs to 11.037 ms in Full Frame scan
- Sequencer trigger mode for on-the-fly change of gain, exposure and ROI
- Edge Pre-select and Pulse width trigger mode
- LVAL-synchronous/-asynchronous operation (auto-detect)
- Auto iris lens video output allows a wider range of light
- GigE Vision Interface with 10 or 8-bit output
- Programmable GPIO with opto-isolated inputs and outputs
- Comprehensive software tools and SDK for Windows XP/Vista

4. Locations and Functions

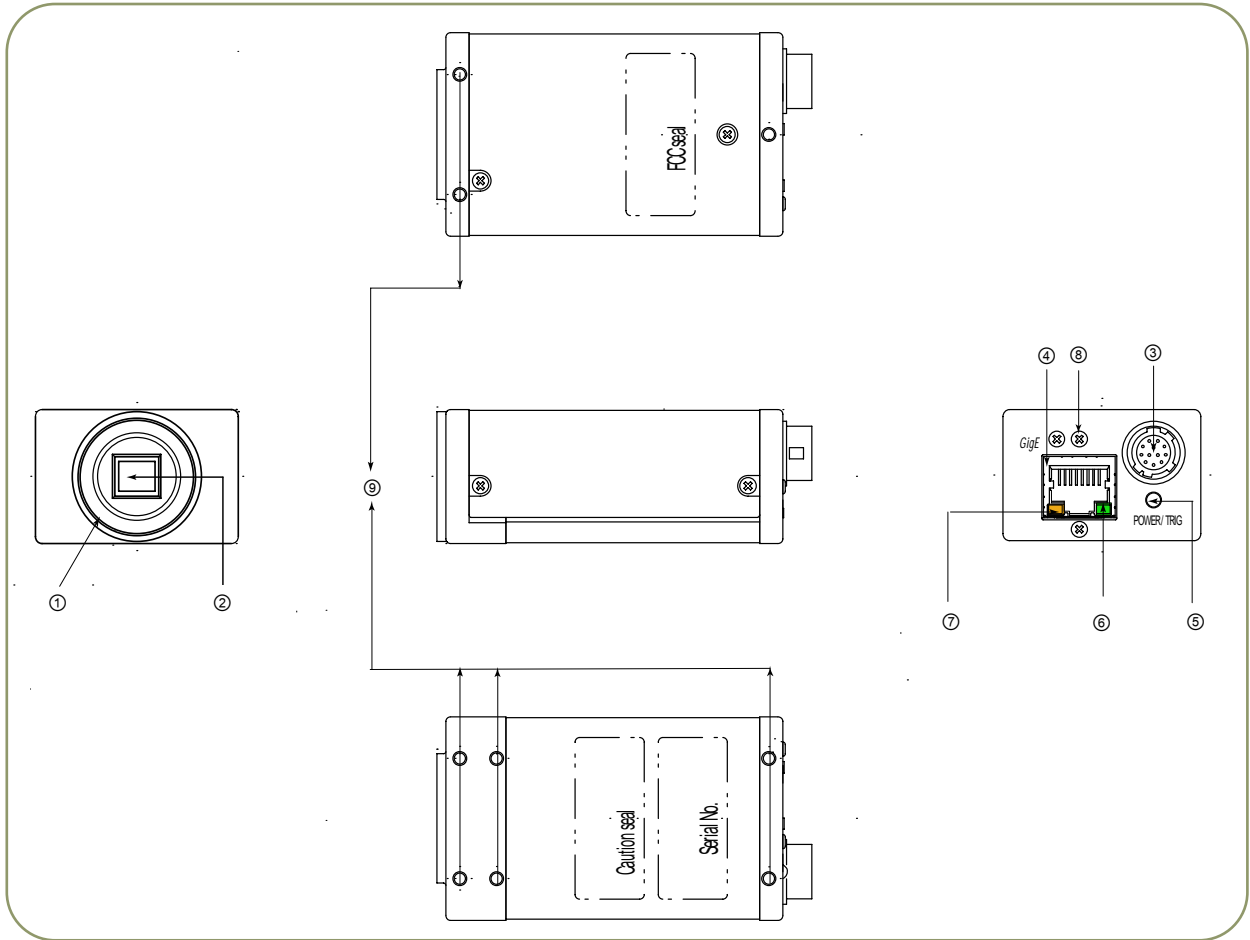

- | | |
|---|--|
| <ul style="list-style-type: none"> ① Lens mount ② CCD sensor ③ 12-pin connector ④ RJ-45 ⑤ LED ⑥ LED ⑦ LED ⑧ Holes for RJ-45 thumbscrews ⑨ Mounting holes | <p>C-mount (Note *1)
 1/3 inch CCD sensor</p> <p>DC +12V power and GPIO interface</p> <p>Gigabit Ethernet connector with threaded holes for thumbscrews</p> <p>Indication for power and trigger input</p> <p>GigE Network condition: LINK</p> <p>GigE Network condition: ACT</p> <p>When an RJ-45 connector with thumbscrews is used, remove the two screws located above and below the Ethernet connector</p> <p>M3 depth 4mm for tripod mount plate (Note * 2)</p> |
|---|--|

*1) Note: Rear protrusion on C-mount lens must be less than 10.0mm.

*2) Note: Either MP-40 or MP-41 can be used together with this camera.

Fig. 1. Locations

5. Pin Assignment

5.1 12-pin Multi-connector (DC-in/GPIO/Iris Video)

Type: HR10A-10R-12PB
(Hirose) male.
(Seen from rear of camera.)

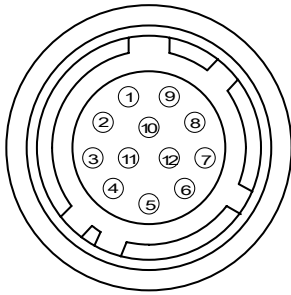

Pin no.	Signal	Remarks
1	GND	
2	+12 V DC input	
3	Opt IN 2 (-) / GND (*1)	GPIO IN / OUT
4	Opt IN 2 (+)/Iris Video out (*1)	
5	Opt IN 1 (-)	
6	Opt IN 1 (+)	
7	Opt Out 1 (-)	
8	Opt Out 1 (+)	
9	Opt Out 2 (-)	
10	Opt Out 2 (+)	
11	+ 12 V DC input	
12	GND	

Fig. 2. 12-pin connector.

*1: Iris Video output function can be set by the internal DIP switch.

5.2 Digital Output Connector for Gigabit Ethernet

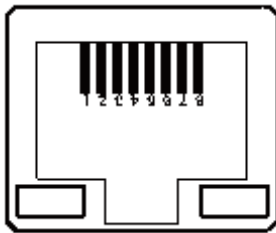

Type: RJ-45
HFJ11-1G02E-L21RL or equivalent
The CM-140GE and CB-140GE cameras also accept industrial RJ-45 connectors with thumbscrews. This assures that the connector does not come undone in tough industrial environments. Please contact the nearest JAI distributor for details on recommended industrial RJ-45 connectors.

Fig. 3. Gigabit Ethernet connector

The digital output signals follow the Gigabit Ethernet interface using RJ-45 conforming connector. The following is pin assignment for Gigabit Ethernet connector.

Pin No	In/Out	Name
1	In/Out	MX1+ (DA+)
2	In/Out	MX1- (DA-)
3	In/Out	MX2+ (DB+)
4	In/Out	MX3+ (DC+)
5	In/Out	MX3- (DC-)
6	In/Out	MX2- (DB-)
7	In/Out	MX4+ (DD+)
8	In/Out	MX4- (DD-)

6. GPIO (Inputs and outputs)

6.1 Overview

All input and output signals pass through the GPIO (General Purpose Input and Output) module. The GPIO module consists of a Look-Up Table (LUT - Cross-Point Switch), 4 Pulse Generators and a 12-bit counter. In the LUT, the relationship between inputs, counters and outputs is governed by internal register set-up.

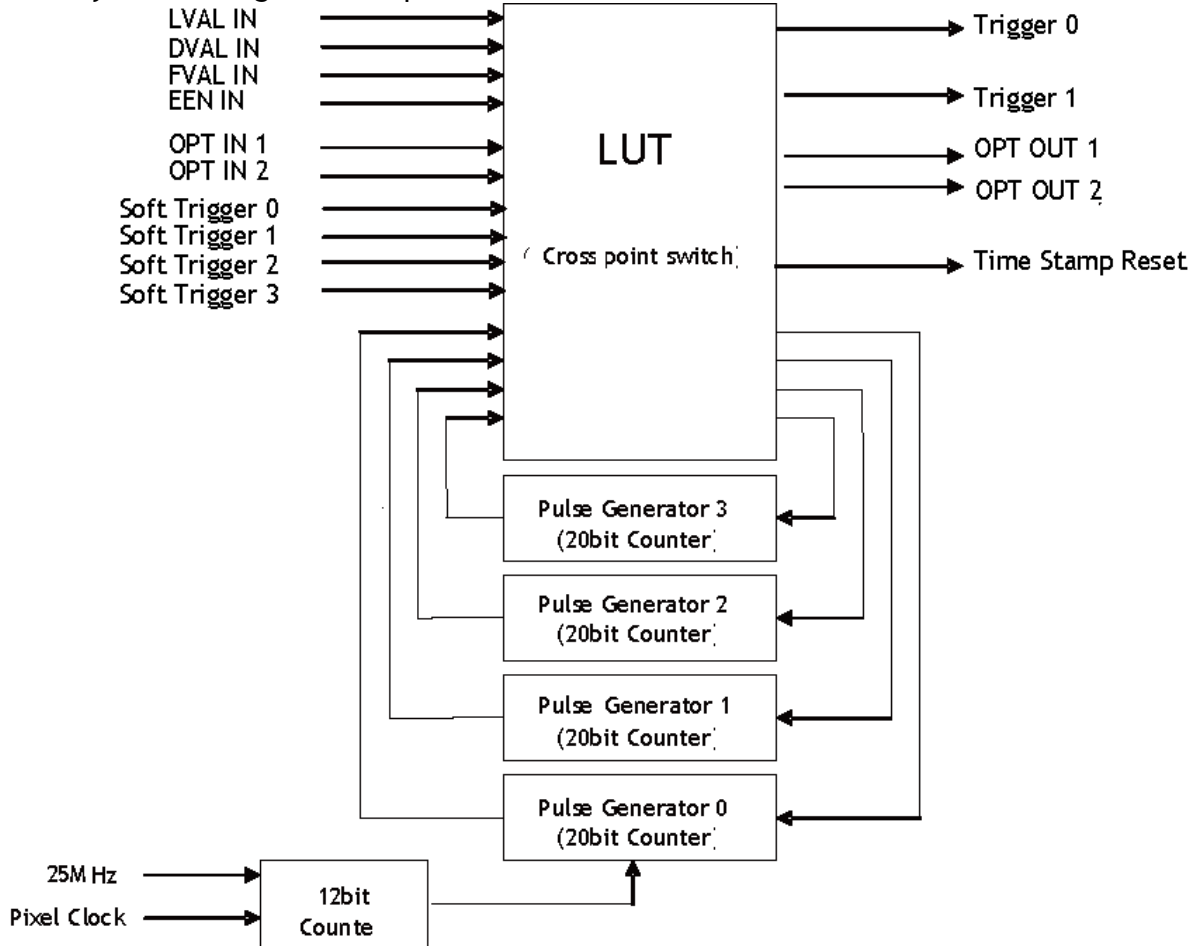

On the above block diagram, Trigger 0 is used for Exposure and Trigger 1 is used for Delayed Readout. The Time Stamp Reset can reset the time stamp complied with GigE Vision standard. This is used for having the same time stamp in case of using multiple cameras.

The blocks shown in the above diagram have the following functionality:

6.1.1 LUT (Look Up Table)

The LUT works as a cross-point switch, which allows connecting inputs and outputs freely. The signals LVAL_IN, DVAL_IN, FVAL_IN and EEN_IN all originate from the camera timing circuit.

Trigger 0 is connected to the camera's timing circuit and is used for initiating triggered exposure. Trigger 1 is used for Delayed Readout mode. The Time Stamp Reset signal is used reset the camera's time stamp function, also making it possible to reset and synchronize the time stamp of multiple cameras.

6.1.2 12-bit Counter

A 25 MHz clock or the camera pixel clock (40 MHz) can be used as a source. The counter has a “Divide by N”, where N has the range 1 through 4096, allowing a wide range of clock frequencies to be programmed. Setting Value 0 is bypass, setting value 1 is 1/2 dividing and setting value 4095 is 1/4096 dividing.

6.1.3 Pulse Generators (0 to 3)

Each pulse generator consists of a 20-bit counter. The behavior of these signals is defined by their pulse width, start point, end point and number of repetitions.

The pulse generator signals can be set in either triggered or periodic mode.

In triggered mode, the pulse is triggered by the rising edge/falling edge/high level or low level of the input signal.

In periodic mode, the trigger continuously generates a signal that is based on the configured pulse width, starting point and end point.

6.2 Opto-isolated Inputs/Outputs

The control interface of the C3 GigE Vision camera series has opto-isolated inputs and outputs, providing galvanic separation between the camera's inputs/outputs and peripheral equipment. In addition to galvanic separation, the opto-isolated inputs and outputs can cope with a wide range of voltages; the voltage range for inputs is +3.3V to +24V DC whereas outputs will handle +5V to +24V DC.

The below figure shows the functional principle (opto-coupler) of the opto-isolated inputs/outputs.

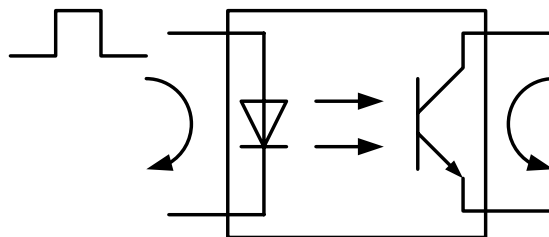

Fig.4. Opto-coupler

6.2.1 Recommended External Input circuit diagram for customer

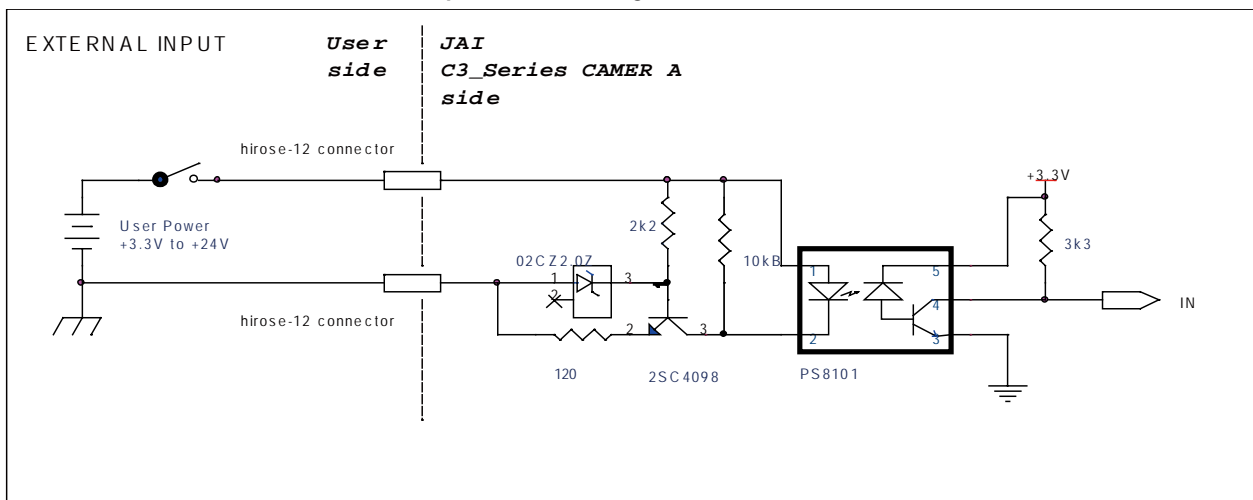

Fig.5 External Input Circuit, OPT IN 1 and 2

6.2.2 Recommended External Output circuit diagram for customer

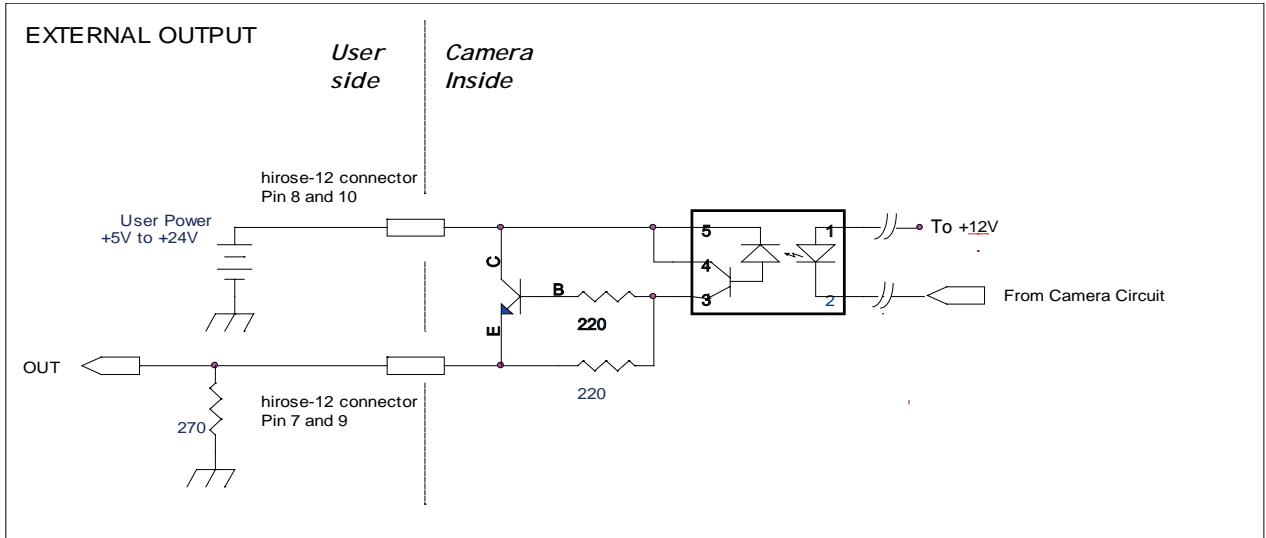
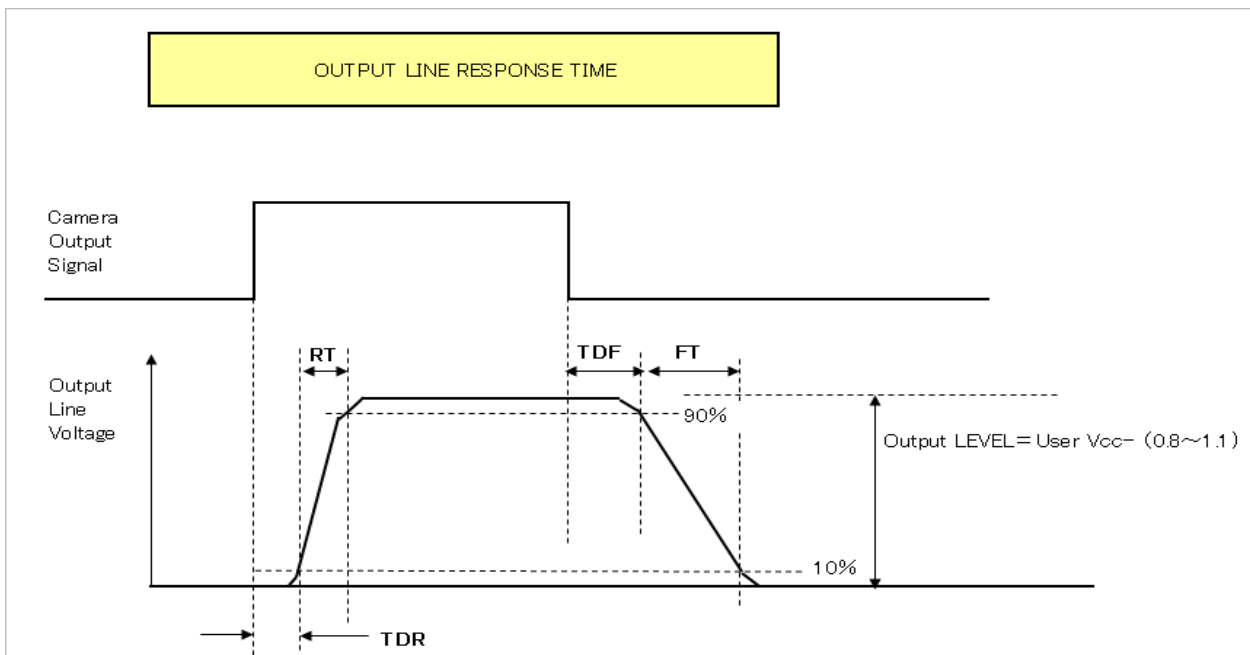

Fig.6. External Output Circuit , OPT OUT 1 and 2

6.2.3 Optical Interface Specifications

The relation of the Input signal and the output signal through optical interface is as follows.



		User Power (VCC)			
		3.3V	5V	12V	24V
Time Delay Rise	TDR (us)	0.54	0.54	0.62	0.68
Rise Time	RT (us)	1.2	1.2	2.0	3.0
Time Delay Fall	TDF (us)	1.5	1.5	2.4	2.1
Fall Time	FT (us)	3.6	3.4	4.5	6.8

Fig.7. Optical Interface Performance

6.3 Inputs and outputs table

		Output Port								
		Trigger 0	Trigger 1	OPT OUT1	OPT OUT2	Time Stamp Reset	Pulse Gen. 0	Pulse Gen. 1	Pulse Gen. 2	Pulse Gen. 3
Input Port	LVAL IN	x	x	x	x	x	o	o	o	o
	DVAL IN	x	x	x	x	x	o	o	o	o
	FVAL IN	x	x	x	x	x	o	o	o	o
	EEN IN	x	x	o	o	x	o	o	o	o
	OPT IN 1	o	o	o	o	o	o	o	o	o
	OPT IN 2	o	o	o	o	o	o	o	o	o
	Soft Trigger 0	o	o	o	o	o	o	o	o	o
	Soft Trigger 1	o	o	o	o	o	o	o	o	o
	Soft Trigger 2	o	o	o	o	o	o	o	o	o
	Soft Trigger 3	o	o	o	o	o	o	o	o	o
	Pulse Gen. 0	o	o	o	o	o	x	o	o	o
	Pulse Gen. 1	o	o	o	o	o	o	x	o	o
	Pulse Gen. 2	o	o	o	o	o	o	o	x	o
	Pulse Gen. 3	o	o	o	o	o	o	o	o	x

LEGEND: 0 = valid combination / x = Not valid (do not use this combination)

6.4 Configuring the GPIO module (register settings)

6.4.1 Input/Output Signal Selector

Address	Internal Name	GenIcam Name	Access	Size	Value (Range)
0xB060	Selector CAMERA Trigger 0 (for Camera Trigger)	Camera Trigger 0	R/W	4	GPIO Selector: 0x00:CAMERA LVAL IN 0x01:CAMERA DVAL IN 0x02:CAMERA FVAL IN 0x03:CAMERA EEN IN 0x04:GPIO Port 1 IN 0x05:GPIO Port 2 IN 0x0C:SOFT TRIG 0 0x0D:SOFT TRIG 1 0x0E:SOFT TRIG 2 0x0F:SOFT TRIG 3 0x10:Pulse Generator 0 0x11: Pulse Generator 1 0x12: Pulse Generator 2 0x13: Pulse Generator 13 0x7F:No Connect
0xB064	Selector CAMERA Trigger 1 (For Delayed Trigger)	Camera Trigger 1	R/W	4	
0xB070	Selector GPIO PORT 1 (Optical Out 1)	GPIO_Port1	R/W	4	
0xB074	Selector GPIO PORT 2 (Optical Out 2)	GPIO_Port2	R/W	4	
0xB090	Pulse Generator 0 Selector	PulseGenerator0	R/W	4	
0xB094	Pulse Generator 1 Selector	PulseGenerator1	R/W	4	
0xB098	Pulse Generator 2 Selector	PulseGenerator2	R/W	4	
0xB09C	Pulse Generator 3 Selector	PulseGenerator3	R/W	4	
0xB0A0	Selector Time Stamp Reset	TimeStampReset	R/W	4	

6.4.2 12-bit counter

Address	Internal Name	GenIcam Name	Access	Size	Value (Range)
0xB000	Counter Clock Choice	ClockSource	R/W	4	0x00: 25MHz 0x01: Pixel Clock
0xB004	Counter Dividing Value	ClockPreScaler	R/W	4	0x000: Bypass 0x001: 1/2 Dividing 0x002: 1/3 Dividing 0xFFFF: 1/4096 Dividing

6.4.3 Pulse generators (20-bit x 4)

There are 4 pulse generators (designated 0 through 3) that can be used to create various timing scenarios by programming start point, endpoint, length and repeats.

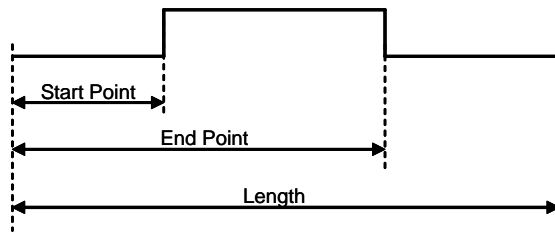

Address	Internal Name	GenIcam name	Access	Size	Value (range)
0xB008	Length Counter 0		R/W	4	0x00001 to 0xFFFFF
0xB00C	Start point Counter 0(1)		R/W	4	0x00000 to 0xFFFFF
0xB010	Start point Counter 0(2)		R/W	4	0x00: infinite 0x01: 1 time 0xFF: 255 times
0xB014	End point Counter 0		R/W	4	0x00001 to 0xFFFFF
0xB018	Counter Clear 0		R/W	4	0x00: Free Run 0x01: High Level Clear 0x02: Low Level Clear 0x04: Rising Edge Clear 0x08: Falling Edge Clear
0xB01C	Length Counter 1		R/W	4	0x00001 to 0xFFFFF
0xB020	Start point Counter 1(1)		R/W	4	0x00000 to 0xFFFFF
0xB024	Start point Counter 1(2)		R/W	4	0: Infinite 1: 1 time 255: 255 times
0xB028	End point Counter 1		R/W	4	0x00001 to 0xFFFFF
0xB02C	Counter 1 Clear		R/W	4	0x00: Free Run 0x01: High Level Clear 0x02: Low Level Clear 0x04: Rising Edge Clear 0x08: Falling Edge Clear

Address	Internal Name	GenIcam name	Access	Size	Value (range)
0xB030	Length Counter 2		R/W	4	0x00001 to 0xFFFFF
0xB034	Start point Counter 2(1)		R/W	4	0x00000 to 0xFFFFF
0xB038	Start point Counter 2(2)		R/W	4	0x00: Infinite 0x01: 1 time 0xFF: 255 times
0xB03C	End point Counter 2		R/W	4	0x00001 to 0xFFFFF
0xB040	Counter 2 Clear		R/W	4	0x00: Free Run 0x01: High Level Clear 0x02: Low Level Clear 0x04: Rising Edge Clear 0x08: Falling Edge Clear
0xB044	Length Counter 3		R/W	4	0x00001 to 0xFFFFF
0xB048	Start point Counter 3(1)		R/W	4	0x00000 to 0xFFFFF
0xB04C	Start point Counter 3(2)		R/W	4	0x00: Infinite 0x01: 1 time 0xFF: 255 times
0xB050	End point Counter 3		R/W	4	0x00001 to 0xFFFFF
0xB054	Counter 3 Clear		R/W	4	0x00: Free Run 0x01: High Level Clear 0x02: Low Level Clear 0x04: Rising Edge Clear 0x08: Falling Edge Clear

6.5 GPIO programming examples

6.5.1 GPIO Plus PWC shutter

Example: 10µs unit pulse width exposure control (PWC).
Pixel clock is 40MHz. 400 clocks (500-100) equals 10µs.

Address	Register	Value
0xA040	Trigger Mode	2 = PWC (Pulse Width Control)
0xB000	Clock Choice	1 = Pixel Clock (40 MHz)
0xB004	Counter Dividing Value	0 = Pass through
0xB008	Length Counter 0	1000 Clocks
0xB00C	Start point Counter 0	100 Clocks
0xB010	Repeat Count 0	1
0xB014	End point Counter 0	500 Clocks
0xB018	Counter Clear 0	4 = Rising Edge Clear
0xB060	CAMERA TRIGGER Selector	11 = pulse generator 0
0xB090	Pulse Generator 0 Selector	4 =OPT IN 1

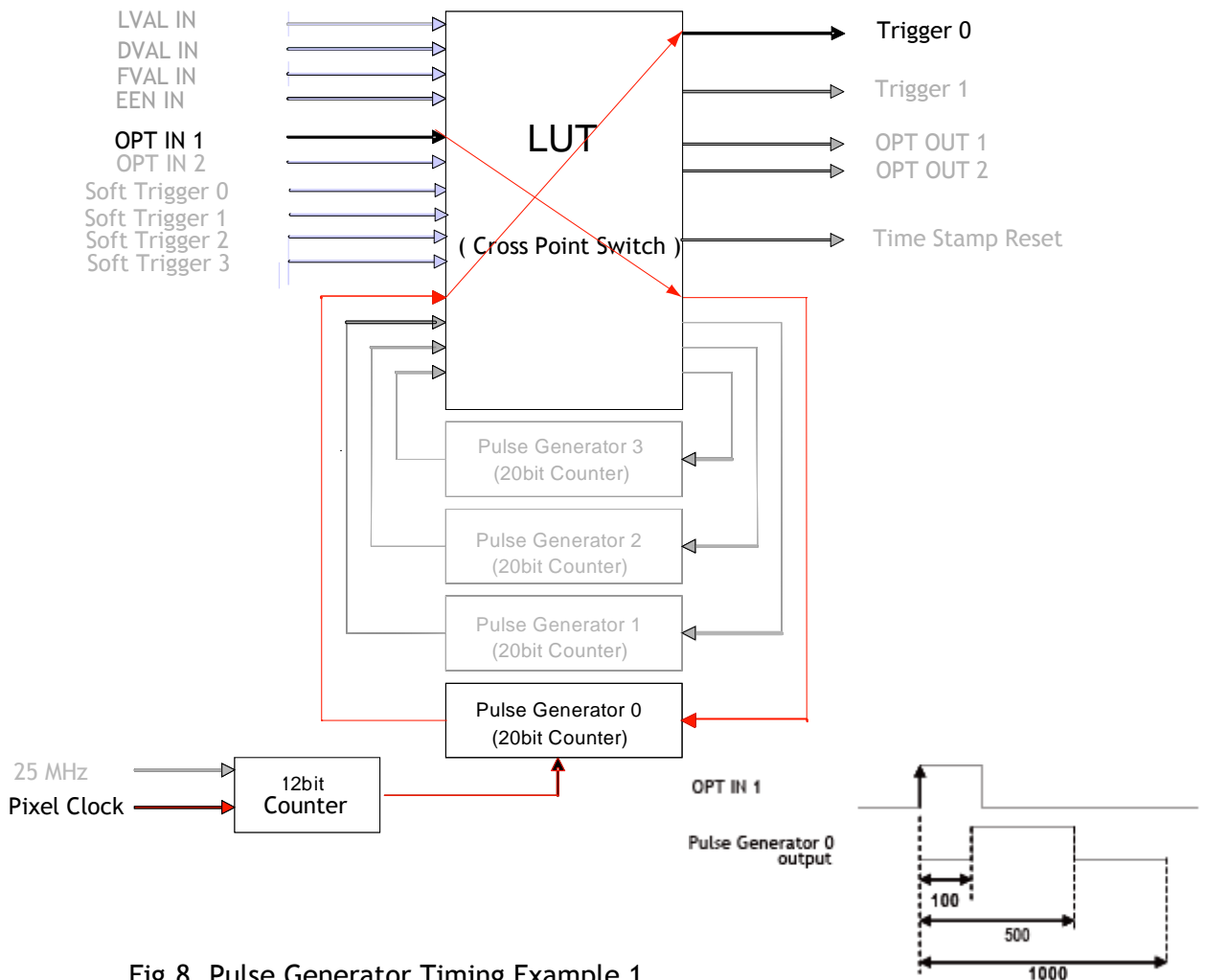

Fig.8. Pulse Generator Timing Example 1

6.5.2 Internal Trigger Generator

Create a trigger signal and trigger the camera

Address	Register	Value
0xA040	Trigger Mode	1 = EPS
0xB000	Clock Choice	1 = Pixel Clock
0xB004	Counter Dividing Value	863 = 1/864 dev(Line Rate)
0xB008	Length Counter 0	1000 Clocks
0xB00C	Start point Counter 0	100 Clocks
0xB010	Repeat Count 0	0 = Free Run
0xB014	End point Counter 0	500 Clocks
0xB018	Counter Clear 0	0 = No Clear
0xB058	CAMERA TRIGGER Selector	11 = pulse generator 0

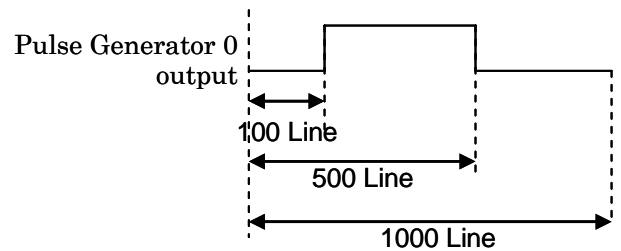
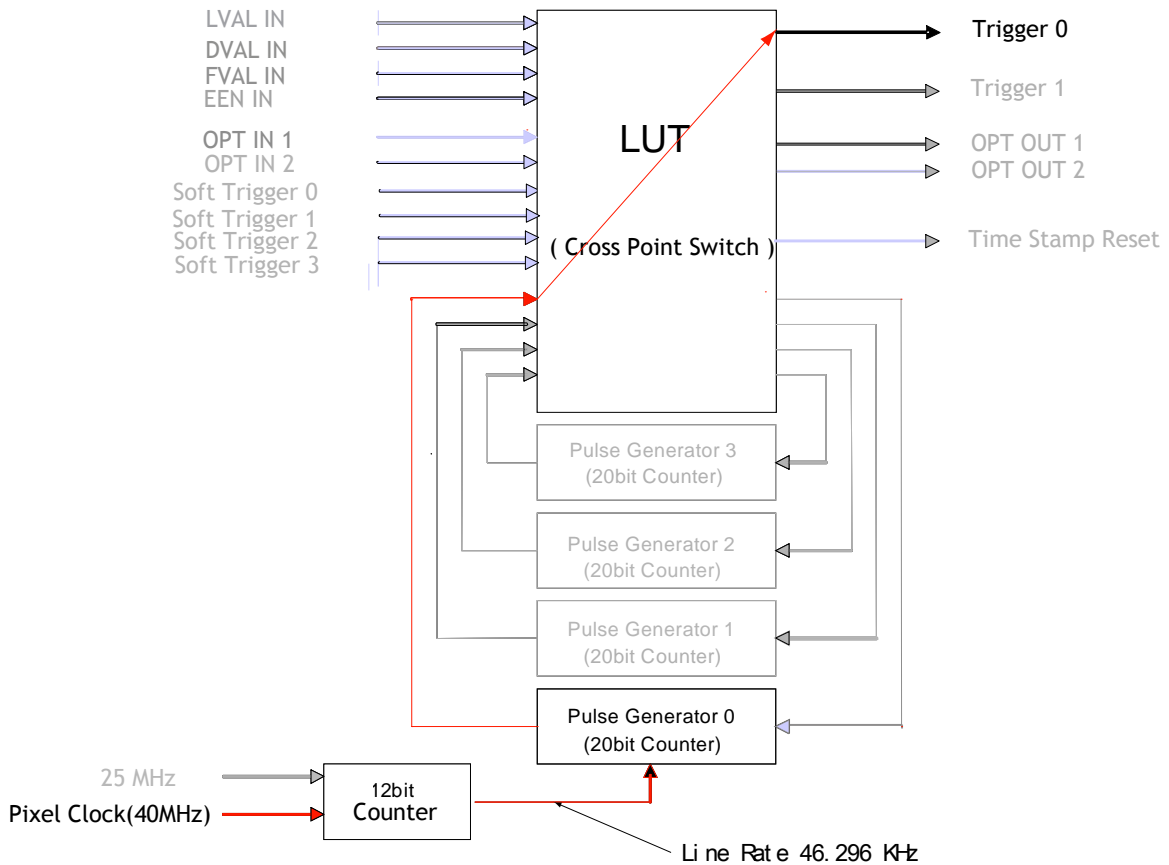

Fig.9. Pulse Generator 0 timing Example 2

7. GigE Vision Streaming Protocol (GVSP)

7.1 Digital Video Output (Bit Allocation)

Although the CM-030GE and CB-030GE are digital cameras, the image is generated by an analog component, the CCD sensor.

The table and diagram below show the relationship between the analog CCD output level and the digital output.

CCD out	Analog Signal *	Digital Out(10-bit)
Black	Setup 3.6%, 25mV	32LSB
200mV	700mV	890LSB
230mV	800mV	1023LSB

The standard setting for 10-bit video level is 890 LSB. 200 mV CCD output level equals 100% video output.

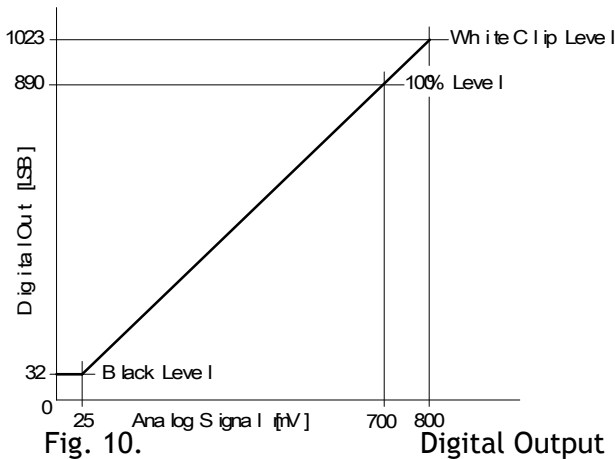

7.2 Bit Allocation (Pixel Format / Pixel Type) - CM-030GE

In the GigE Vision Interface, GVSP (GigE Vision Streaming Protocol) is used for an application layer protocol relying on the UDP transport layer protocol. It allows an application to receive image data, image information and other information from a device.

In the monochrome camera, CM-030GE, the following pixel types supported by GVSP are available.

With regard to the details of GVSP, please refer GigE Vision Specification available from AIA (www.machinevisiononline.org).

7.2.1 GVSP_PIX_MONO8 (8bit)

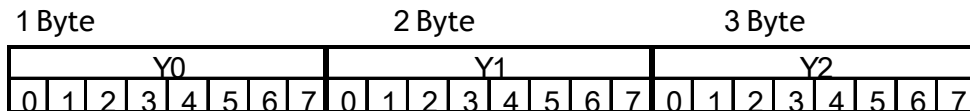

7.2.2 GVSP_PIX_MONO10 (10bit)

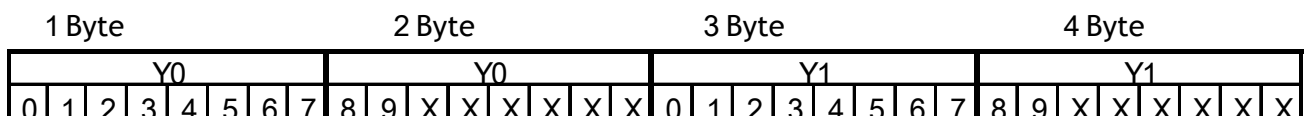

7.2.3 GVSP_PIX_MONO10_PACKED (10 bit)

Y0										Y1										Y2										Y3																	
2	3	4	5	6	7	8	9	0	1	X	X	0	1	X	X	2	3	4	5	6	7	8	9	2	3	4	5	6	7	8	9	0	1	X	X	0	1	X	X	2	3	4	5	6	7	8	9

Address	Internal Name	Access	Size	Value
0xA410	Pixel Format type	R/W	4	0x01080001:Mono8 0x01100003:Mono10 0x010C0004:Mono10 Packed

7.3 Bit Allocation (Pixel Format / Pixel Type) - CB-030GE

In the GigE Vision Interface, GVSP (GigE Vision Streaming Protocol) is used for an application layer protocol relying on the UDP transport layer protocol.

With regard to the details of the GVSP, please refer GigE Vision Specification available from AIA (www.machinevisiononline.org).

7.3.1 GVSP_PIX_BAYRG8 "BayreRG8 "

Odd Line

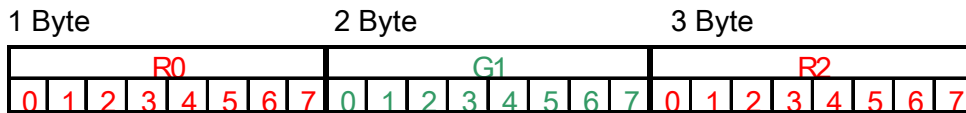

Even Line

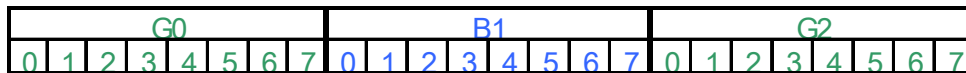

7.3.2 GVSP_PIX_BAYRG10 "Bayer RG10"

Odd Line

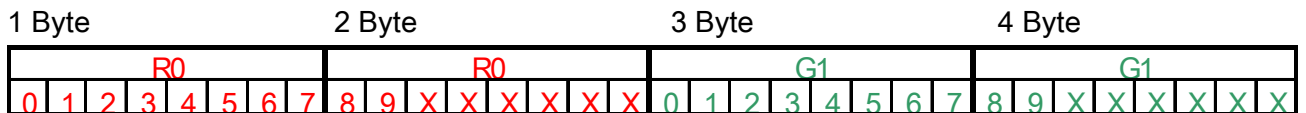

Even Line



7.3.3 GVSP_PIX_BAYGB8 "BayerGB8"

Odd Line

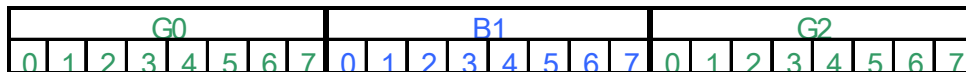

Even Line

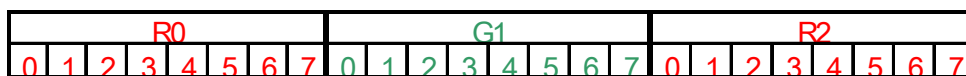

CM-030 GE / CB-030 GE

7.3.4 GVSP_PIX_BAYGB10 "BayerGB10"

Odd Line

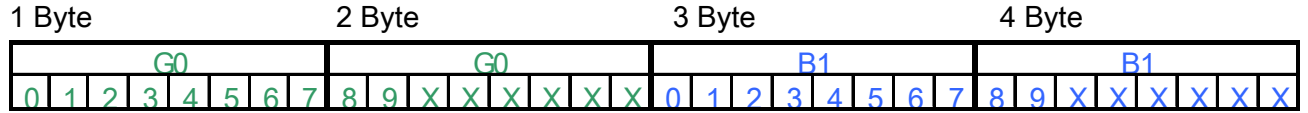

Even Line



Address	Internal Name	Access	Size	Value
0xA410	Pixel Format type	R/W	4	0x01080009: BAYRG8 0x0108000A: BAYGB8 0x0110000D: BAYRG10 0x0110000E: BAYGB10

Note: CB-030GE has the same Bayer sequence for Full and any of partial scanning as RG. Therefore, comparing full scanning and partial scanning, the center might be shifted.

As the Pixel Format type, CB-030GE supports BAYER GB 8 and BAYER GB 10. When this type is selected, the output starts from 2nd line for all scanning.

8. Functions and Operations

8.1 GigE Vision Standard Interface

The CM-030GE and CB-030GE are designed in accordance with the GigE Vision standard. It transmits digital images over Cat5e or Cat6 Ethernet cables. All camera functions are also controlled via the GigE Vision interface.

The camera can operate in continuous mode, providing an endless stream of images. For capturing individual images, related to a specific event, the camera can also be triggered. For precise triggering, it is recommended to use a hardware trigger applied to the Hirose 12-pin connector. It is also possible to initiate a software trigger through the GigE Vision interface. However, when using software trigger, certain latency inherent to the GigE interface must be anticipated. This latency, that manifests itself as jitter, greatly depends on the general conditions and traffic on the GigE connection. The frame rate described in this manual is for the ideal case and may deteriorate depending on conditions.

When using multiple cameras (going through a switch and/or a single path) or when operating in a system with limited transmission bandwidth the Delayed Readout Mode and Inter-Packet Delay functions can be useful.

8.2 Recommended Network Configurations

Although the CM-030GE and CB-030GE conform to Gigabit Ethernet (IEEE 802.3) not all combinations of network interface cards (NICs) and Switches/Routers are suitable for use with the GigE Vision compliant camera.

JAI will endeavor to continuously verify these combinations, in order to give users the widest choice of GigE components for their system design.

8.2.1 Verified Network Interface Cards (NICs)

At the time of publishing this document these combinations have been verified:

NIC manufacturer	Model	PCI Bus	PCI-X Bus	PCI-Express Bus
Intel	PRO/1000MT (PWLA8490MT)	√ (33MHz)	√(100MHz)	–
Intel	PRO/1000GT (PWLA8391GT)	√ (33MHz)	√ (33MHz)	–
Intel	PRO/1000PT (EXPI9300PT)	–	–	√ (x1)

Minimum PC requirements are as follows in order to fulfill the above conditions:

- Intel Core 2 Duo , 2.4GHz or better, alternatively AMD Athlon 64 x2, CPU
- At least 2 GB memory
- Video Card with PCI Express Bus x 16 , VRAM better than DDR2 with 256 MB or more, and display capability of 2560 x 1600
- More than 200 GB free disk space
- Windows XP, SP2 (32bit)
- Do not use screen saver and power save functions.

Pentium 4 type PC is not recommended due to dependency on chip set bus performance.

CM-030 GE / CB-030 GE

8.2.2 Video data rate (network bandwidth)

The video bit rate for CM-030GE and CB-030GE is:

Model	Pixel Type	Packet data volume (In case the Packet size is 1500)
CM-030GE	MONO8	243Mbit/s
	MONO10_PACKED	364Mbit/s
	MONO10	485Mbit/s
CB-030GE	BAYRG8,BAYGB8	243Mbit/s
	BAYRG10,BAYBG10	485Mbit/s

In case using Jumbo Frame, the packet data will be improved by 2 %.

For CM-030GE and CB-030GE, the jumbo frame can be set at maximum 4040 Bytes (Factory setting is 1440 Bytes). To set Jumbo Frame, refer to chapter 8.2.3.

When Optical Black pixels are transferred with the image (OB transfer mode enabled), the maximum packet value is **TBD** Mbit/s.

To ensure the integrity of packets transmitted from the camera is recommended to follow these simple guidelines:

1. Whenever possible use a peer-to-peer network.
2. When connecting several cameras, going through a network switch, make sure it is capable of handling jumbo packets and that it has sufficient memory capacity.
3. Configure inter-packet delay to avoid congestion in networks switches.
4. Disable screen saver and power save functions on computers.
5. Use high performance computers with multi-CPU, hyper-thread and 64-bit CPU, etc.
6. Only used Gigabit Ethernet equipment and components together with the camera.
7. Use at least Cat5e or preferably Cat6 Ethernet cables.
8. Whenever possible, limit the camera output to 8-bit.

8.2.3 How to set Jumbo Frame (in Windows™ XP environments)

- (1) Click **[start]** and click **[Control Panel]**.
- (2) Click **[Performance and Maintenance]**.
- (3) Click **[System]**.
- (4) Click **[Hardware]** tab.
- (5) Click **[Device Manager]**.

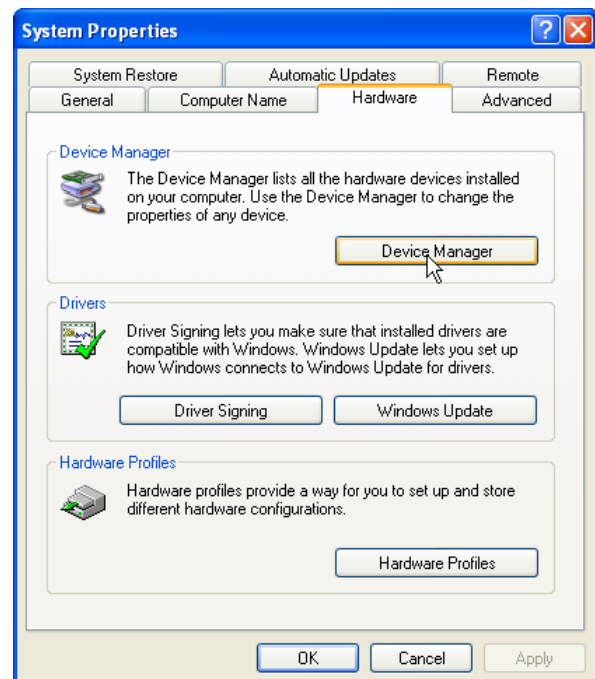

- (6) Expand **[Network adapters]**.
- (7) Select target NIC, **right-click**, and click **[Properties]**.

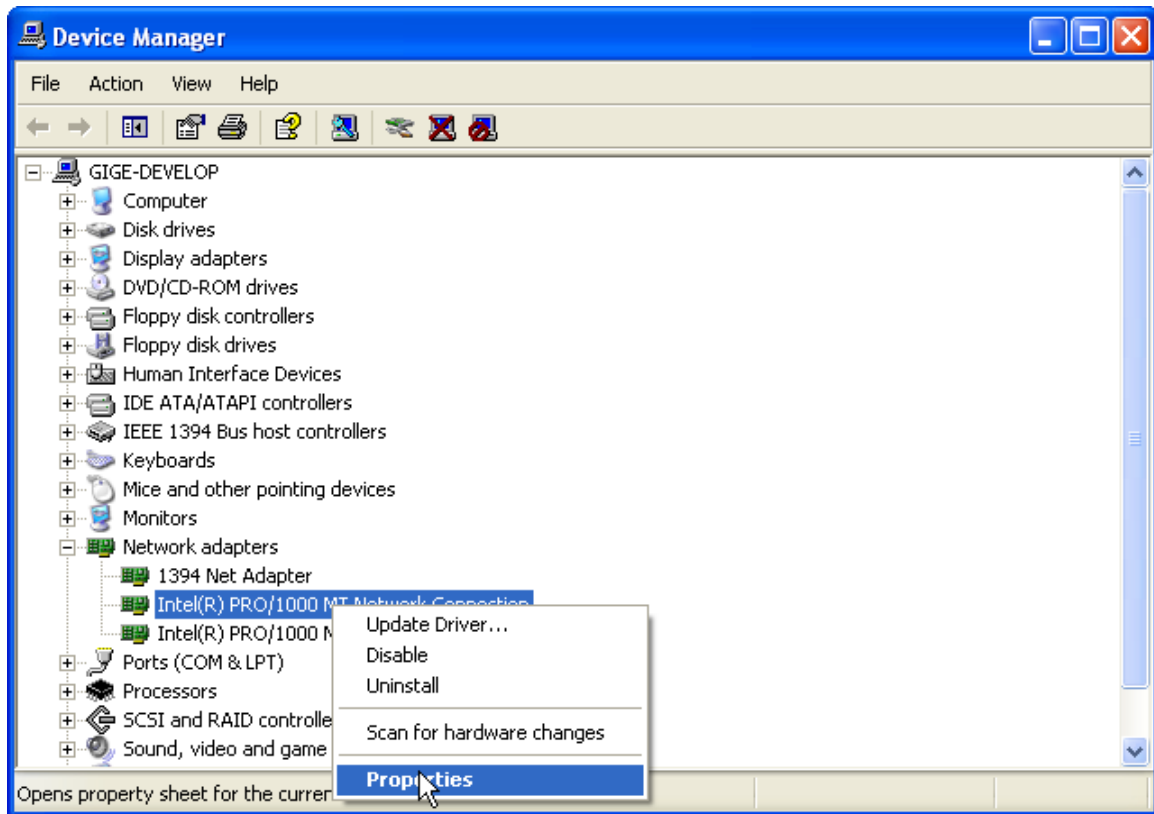

Note: The following is valid if you are using Intel(R) 1000. Accordingly the procedure is different if you use different NIC appeared on Network Adaptors. In that case, set the item of a similar content described here.

(8) Click **[Advanced]** tab.

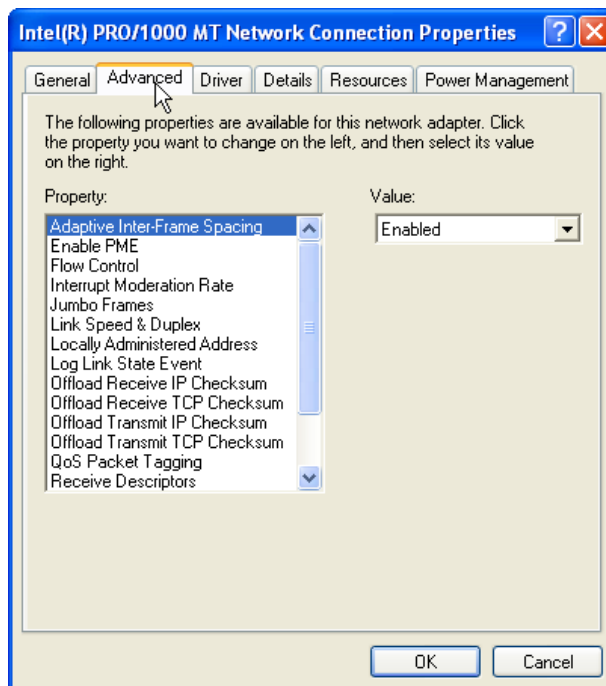

(9) Select **Jumbo Frames** of Property, and select **9014** of Value.

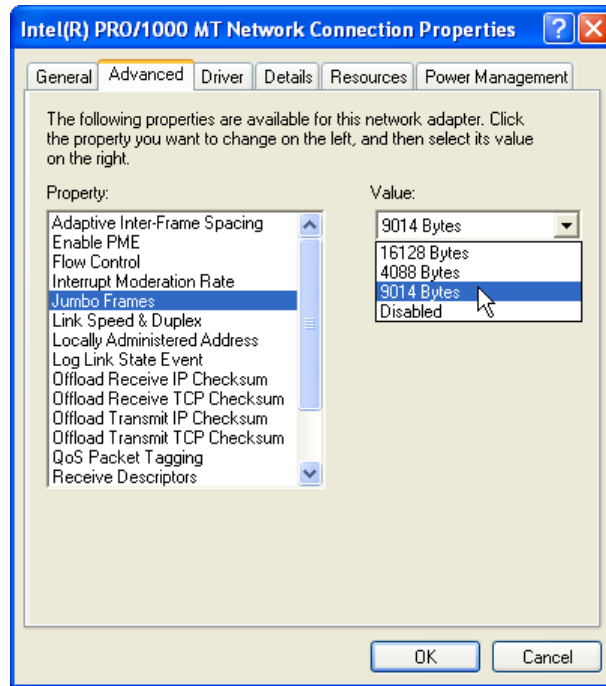

- (10)Click [OK].
- (11)Close [Device Manager].
- (12)Close [System Properties] clicking [OK].

8.2.4 Packet delay

Packet Delay is one of GigE Vision functionalities. This function controls the data bandwidth through network. When the delay value increases, the reliability of transmission is improved but on the other hand, the transfer rate will be decreased. This is set depending on the network conditions.

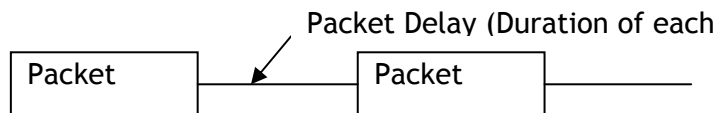

This is set in the camera control tool.

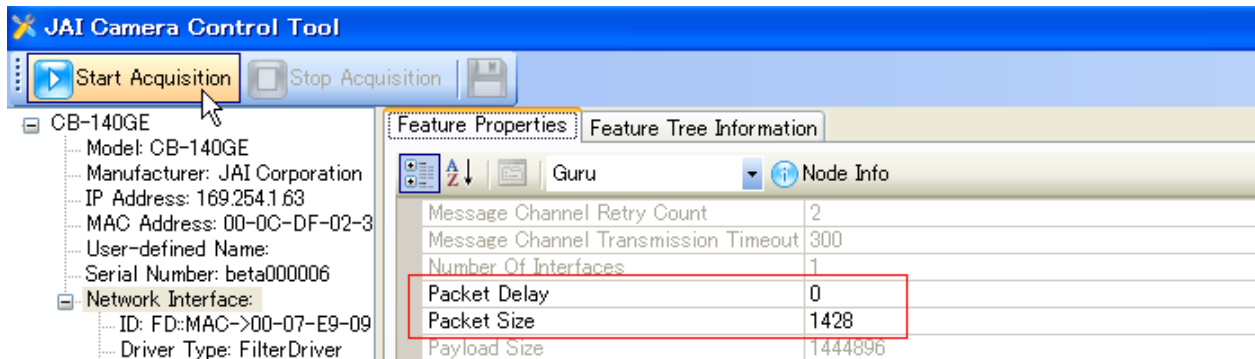

8.3 Basic functions

The CM-030GE and CB-030GE cameras are progressive scan cameras with 10 or 8-bit video output in Gigabit Ethernet. An analogue iris video signal (DIP switch select) can be used for controlling auto-iris lenses.

The camera has 1/2, 1/4 or 1/8 partial scanning for faster frame rates. Vertical binning is also available.

The camera can operate in continuous mode as well as in 4 triggered modes:

- Pre-select
- Pulse width
- Sequential trigger (with pre-selected exposure time)
- Delayed readout (with pre-selected exposure time)

Depending on the timing of the trigger input in relationship to FVAL (camera internal Frame Valid clock), the start of exposure can be immediate (no-delay, LVAL asynchronous) or delayed until next LVAL (LVAL synchronous).

In the following section the functions are described in detail.

8.3.1 Vertical Binning (CM-030GE only).

The binning functions can be used to achieve higher frame rate or higher sensitivity. The drawback is lower resolution.

Vertical binning is done by adding the charge from pixels in adjacent lines in the horizontal CCD register.

Fig. 11 shows the binning principle. Resolution and frame rate for all combinations are shown in the below table.

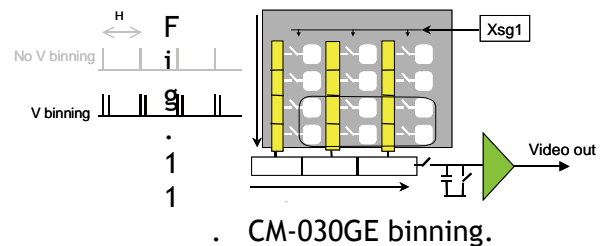

The CM-030GE has ON or OFF function for Vertical Binning:

Setting	Value for Register address 0xA084	Resolution	Frame rate
Off (no binning)	0x01	656(h) x 494(v) pixels	90.5 fps
2:1 binning	0x02	656(h) x 247(v) pixels	166.2 fps

8.3.2 CB-030GE. Bayer filter

CB-030GE is a color camera based on a CCD sensor with a Bayer RGB color mosaic. The color image reconstruction is done in the host PC.

The Color sequence in the video signal is the same for all scanning formats.

The line readout follows LVAL.

The first valid pixel is the same timing as DVAL.

The Bayer color sequence starts with:

RGR for odd numbers.

GBG for even line numbers.

Figure 12 shows the timing sequence for the Bayer mosaic read-out for the available partial scan modes.

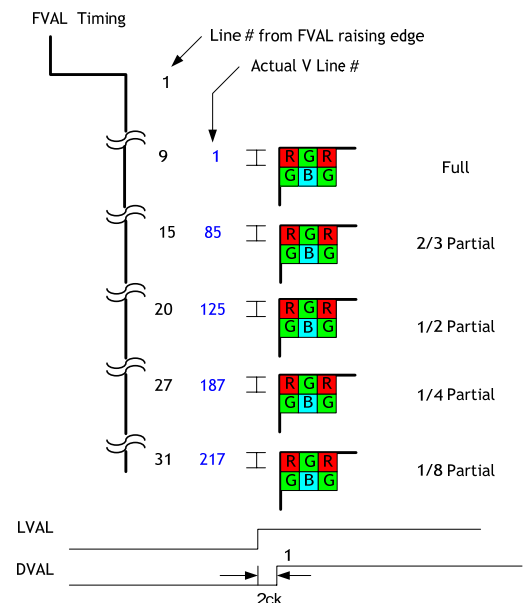

Fig.12. Bayer layout for each scanning

8.3.3 Electronic Shutter

CM-030GE / CB-030GE have conventional shutter functions as well as the GenICam standard “Exposure Time Abs” function.

Preset Shutter

10 steps preset shutter are available: OFF (1/90); 1/100, 1/120; 1/250; 1/500; 1/1,000; 1/2,000; 1/4,000; 1/8,000; 1/10,000 sec.

(See the register map on Section 10 for details how to configure this register - 0xA004)

Programmable Shutter

It is possible to set the shutter speed in the range of 2L to 511L by 1L unit, in case of Full Frame operation. When 511L is set, it is the equivalent of “OFF (1/90)” or 11.037ms.

(See the register map Section 10 for details how to configure this register - 0xA008)

	Minimum Shutter Time 2L	Maximum Shutter Time
Normal	21.6 μs(1L) * 2L = 43.2 μs	21.6 μs * 511L ≈ 11.037ms
V Binning	23.4 μs * 2L = 46.8 μs	23.4 μs * 257L ≈ 6.0138ms

Pulse Width Control

With this mode selected the exposure time is controlled by the width of the trigger pulse. The minimum trigger pulse width is equal to 1L (21.6 μs)

Exposure Time Abs (GenICam Standard)

This is a function specified in the GenICam standard.

The shutter speed can be entered as an absolute exposure time in microseconds (μs) in register address 0xA018. The entered absolute time (Time Abs) is then converted to programmable exposure (PE) value inside the camera.

The below equations show the relationship between the PE value used by the camera for the different readout modes and the “Exposure Time Abs” value entered in register 0xA018. As the calculation is based on rounding down to the closest integer, precise values may not always occur.

The relation between PE value and Time Abs:

Normal readout PE = 2 + INT⁽¹⁾ (Exposure time - 43) μs / (864⁽²⁾ / 40000000⁽³⁾)

V Binning readout PE = 2 + INT (Exposure time - 46) μs / (936 / 40000000)

(1) INT means integer (rounded down). (2) Pixel clocks/line. (3) Pixel clock

The following table shows minimum value and maximum value for each readout mode.

	Minimum value	Maximum Value
Normal Scan	43us	11.037ms 511L
2/3 Partial Scan	43us	7.733ms 358L
1/2 Partial Scan	43us	6.221ms 288L
1/4 Partial Scan	43us	3.867ms 179L
1/8 Partial Scan	43us	2.722ms 126L
V-Binning Scan	46us	6.013ms 257L

GPIO in combination with Pulse Width Trigger

More precise exposure time can be obtained by using GPIO in combination with Pulse Width Trigger mode. The clock generator and counter can be programmed in very fine increments. As for the setting example, refer to chapter 6.5.1.

8.3.4 Auto Iris Lens video output (12-pin Hirose connector)

This analogue signal is not routed through the GPIO. This signal is available at pin 4 of 12-pin Hirose connector. It can be used for lens iris control in Continuous mode only.

The signal is taken from the CCD sensor output before the gain circuit. The video output is without sync. The signal is 0.7 Vpp from <math><400 \Omega</math>. AC coupled.

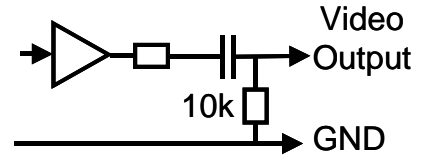

Fig. 13 Video output circuit

To use this signal, the internal DIP switch must be set as follows.

Set switch SW600 to ON (to the left). The factory default is OFF (to the right).

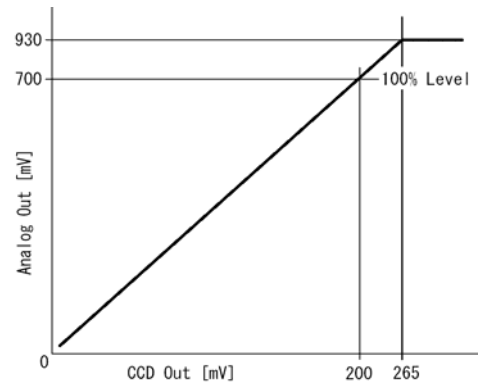

Fig. 14. Iris video output.

8.3.5 Auto-detect LVAL-sync / a-sync. accumulation

This function replaces the manual setting found in older JAI cameras. Whether accumulation is synchronous or a-synchronous in relationship to LVAL depends on the timing of the trigger input.

When trigger is received while FVAL is high (during readout), the camera works in LVAL-synchronous mode, preventing reset feed trough in the video signal. There is a maximum jitter of one LVAL period from issuing a trigger and accumulation start.

If trigger is received when FVAL is low, the cameras works in LVAL-asynchronous mode (no delay) mode. This applies to both pre-select (PS) trigger mode and pulse width trigger (PW) mode.

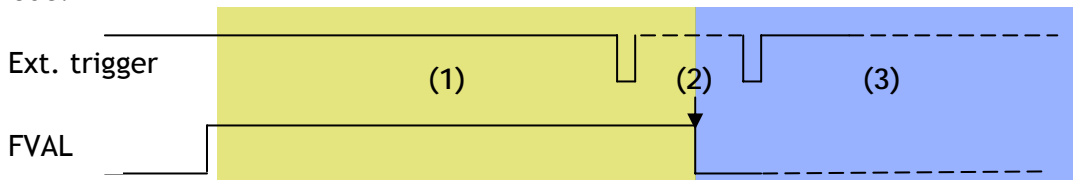

- (1) In this period camera executes trigger at next LVAL (prevents feed-through noise)
- (2) Avoid trigger at FVAL transition (+/- 1 LVAL period), as the function may randomly switch between "next LVAL" and "immediate".
- (3) In this period camera executes trigger immediately (no delay)

Fig. 15. Auto-detect LVAL sync /a-sync accumulation

8.3.6 Rear panel indicator.

The rear panel mounted LED provides the following information:

- Amber: Power connected - initiating
- Steady green : Camera is operating in Continuous mode
- * Flashing green : The camera is receiving external trigger

Ethernet connector indicates,

- Steady green : 1000 Base-T has been connected
- * Flashing green : 100 Base-T or 10 Base-T is connected
- * Flashing amber : Network active in communication

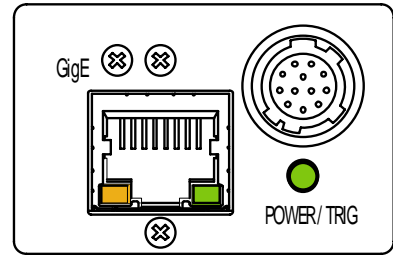

Note: When flashing green, video is not streamed through Ethernet.

Fig.16. Rear Panel

8.4 Sensor Layout and timing

8.4.1 CCD Sensor Layout

The CCD sensor layout with respect to pixels and lines used in the timing and video full frame read out is shown below.

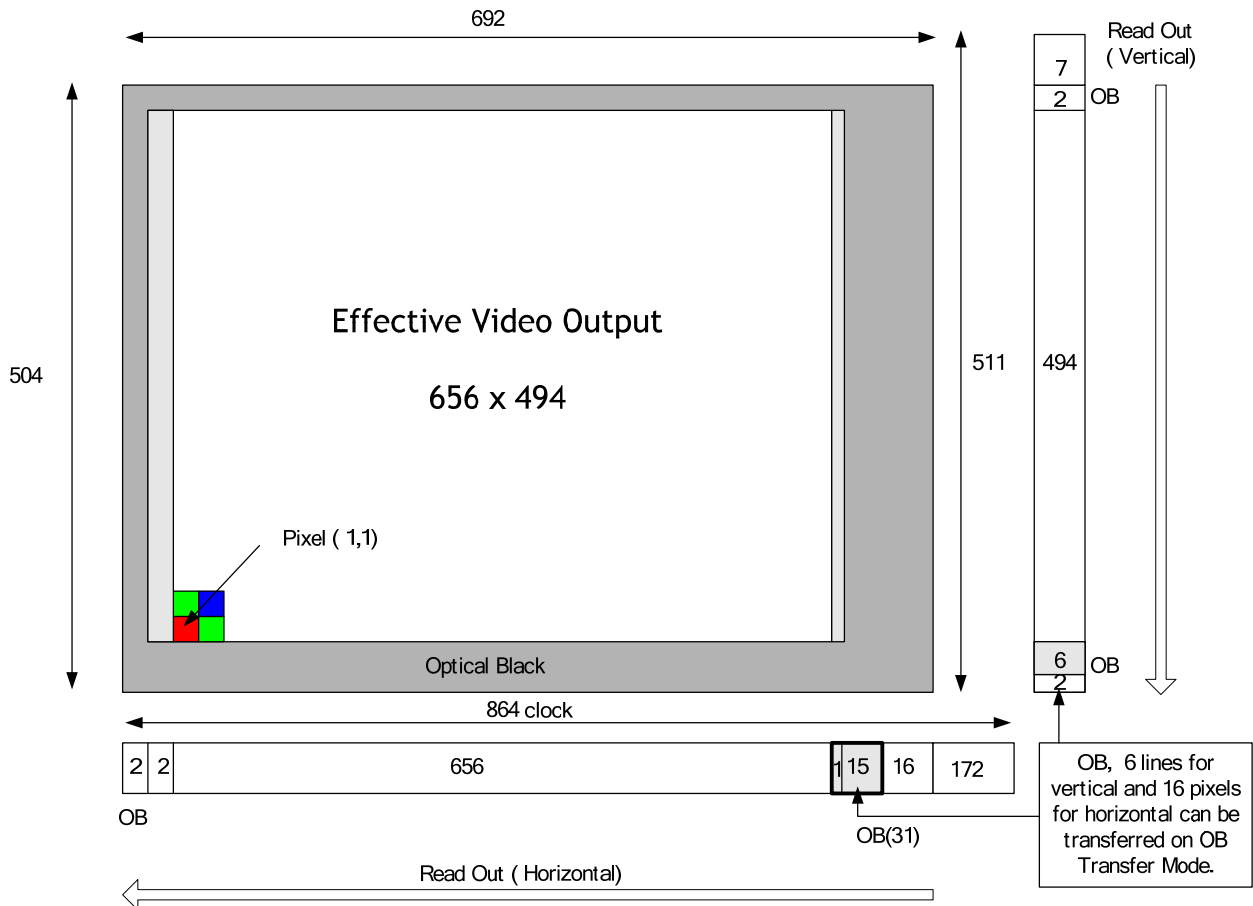

Fig. 17. CCD sensor layout

Important Note: By using the Optical Black (OB) transfer mode, the user can select whether to include optical black pixels in the image stream.

8.4.2 Horizontal timing

The LVAL period is shown for normal continuous mode.

FULL FRAME READ OUT / PATIAL READ OUT

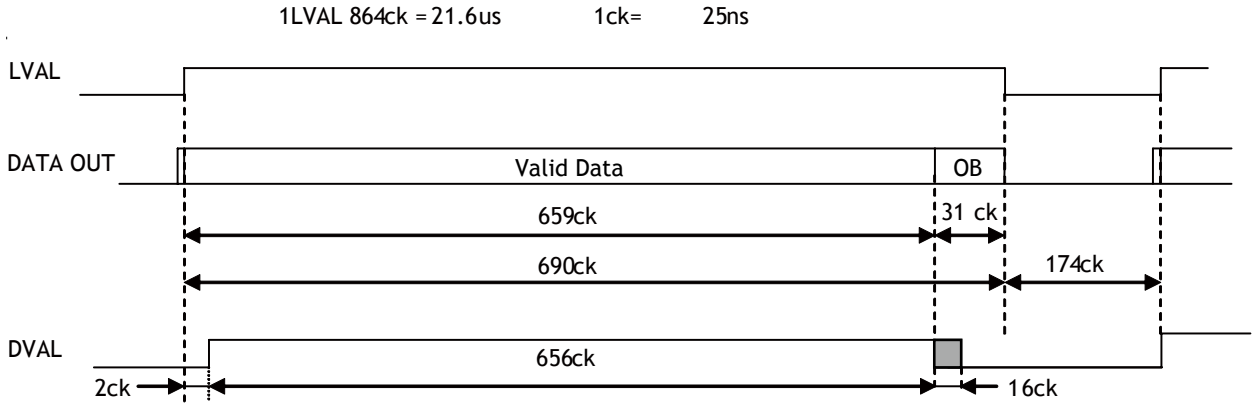

Fig. 18. Horizontal timing

8.4.3 Vertical timing

The FVAL period for normal continuous mode full scan is shown.

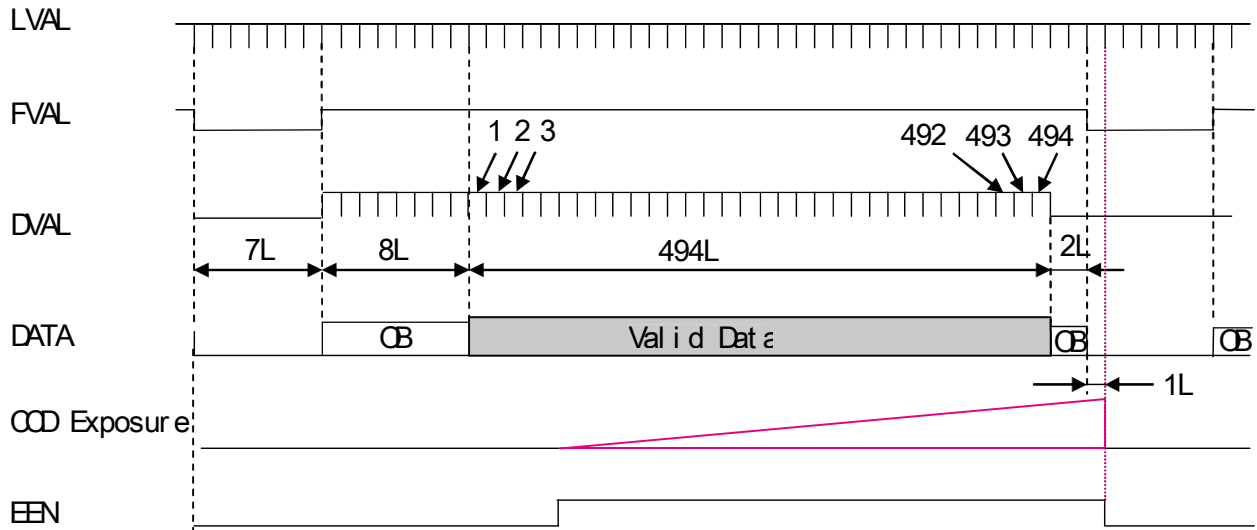

Fig. 19. Vertical timing for full scan

8.4.4 Partial Scanning

The FVAL period is shown for 1/2 partial scan in normal continuous mode.

1 line = 26.7 μs

Vertical Timing

The below diagram and table provide vertical timing information for the fixed partial scan settings 1/2, 1/4, 1/3 and 2/3

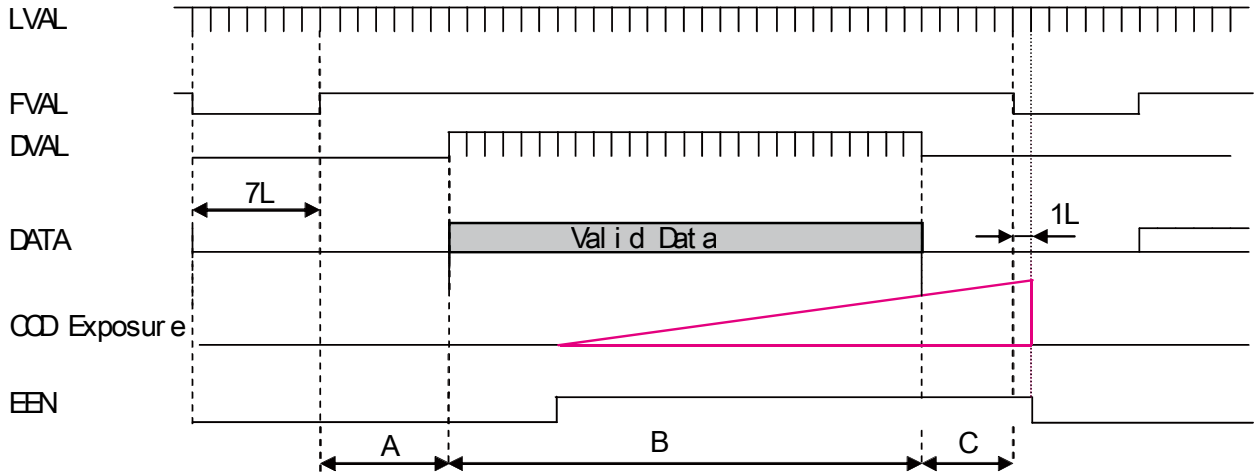

Values for vertical timing in partial scan continuous mode.

AREA	FVAL Low (L)	A (L)	B (L)		C (L)	Total line	frame rate
			Start line	End line			
1/2	7	19	246		18L	290L	159.64
			125	370			
1/4	7	26	122		26L	181L	255.75
			187	308			
1/8	7	30	62		29L	128L	361.68
			217	278			
2/3	7	14	326		13L	360L	128.6
			85	410			

Fig. 20. Vertical timing for partial scanning

Horizontal Timing

The horizontal timing is the same the full scanning.

FULL FRAME READ OUT / PATIAL READ OUT

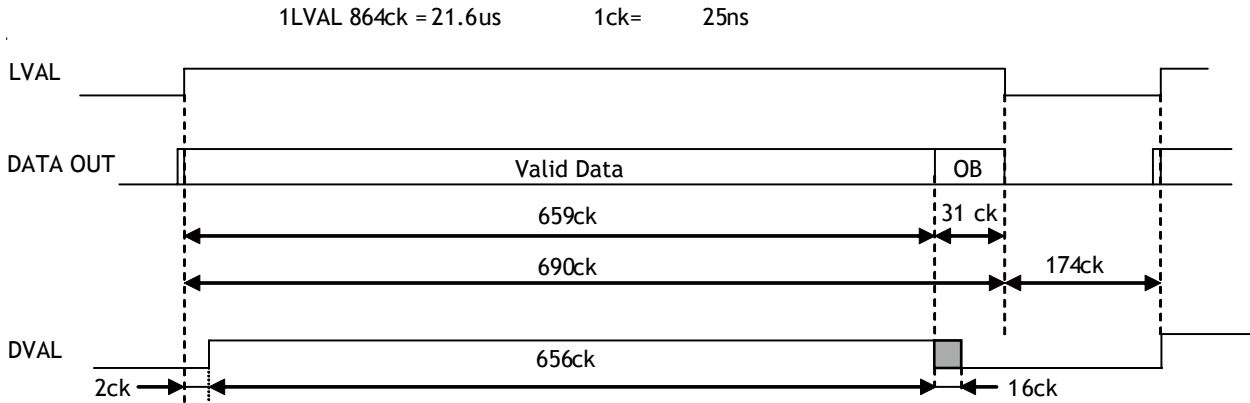

Fig.21. Horizontal Timing for Partial Scanning

8.4.5 Vertical binning

Vertical binning combines charge from two adjacent lines, reducing the vertical resolution to half and at the same time increasing frame rate and sensitivity. By activating this function, the frame rate is increased to 44.492 fps. This function is available only for CM-030GE.

Important Note

Vertical Binning can not be used together with the Partial Scanning.

Horizontal Timing

V binning

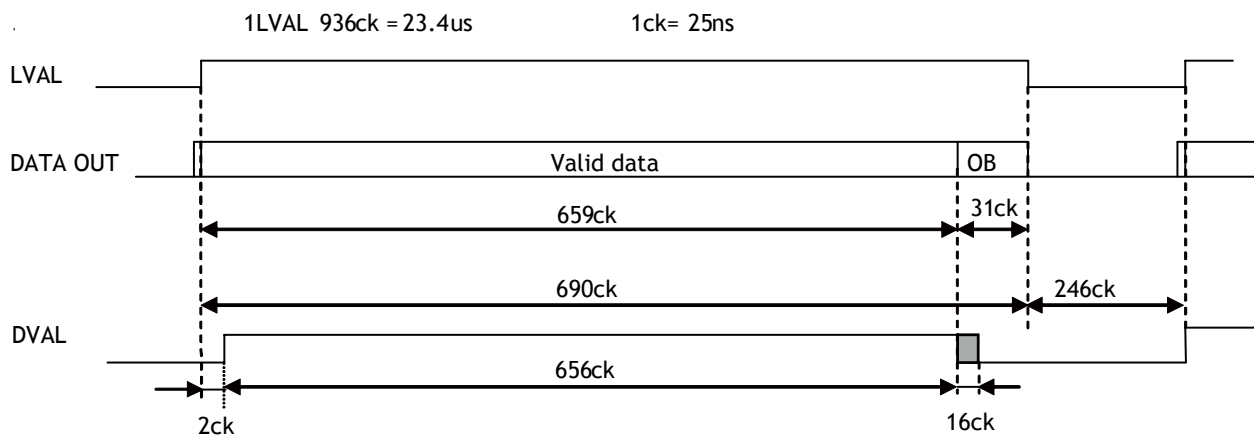

Fig.22. Horizontal Timing for Vertical Binning

Vertical timing

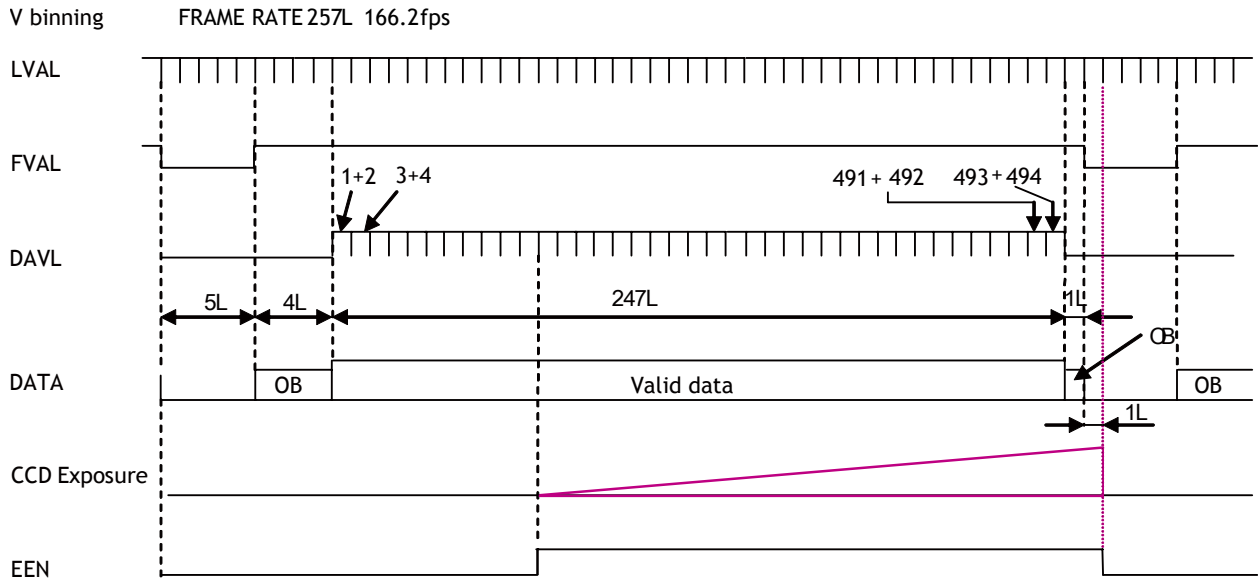

Fig.23. Vertical Timing for Vertical Binning

8.5 Operation Modes

This camera can operate in 5 primary modes.

- | | |
|------------------------------------|----------------------------------|
| 1. <i>Continuous Mode</i> | Pre-selected exposure. |
| 2. <i>Pre-select trigger mode</i> | Pre-selected exposure. |
| 3. <i>Pulse Width trigger mode</i> | Pulse width controlled exposure. |
| 4. <i>Sequential Trigger</i> | Pre-selected exposure |
| 5. <i>Delayed Readout Trigger</i> | Pre-selected exposure |

8.5.1 Continuous operation

For applications not requiring asynchronous external trigger, but where a continuous stream of images is required, this mode should be used.

In this mode it is possible to use a lens with video controlled iris.

For timing details, refer to fig. 18. through fig. 23.

To use this mode:

Set function:	Trigger mode	Continuous
	Scanning	Full, Partial scanning
	Vertical binning	On/Off (CM-030GE only)
	Shutter mode	Preset, Programmable, Auto
	Shutter speed	
	Programmable exposure	

8.5.2 Pre-select Trigger Mode

An external trigger pulse initiates the capture, and the exposure time (accumulation time) is the fixed shutter speed set by registers. The accumulation can be LVAL synchronous or LVAL a-synchronous.

The resulting video signal will start to be read out after the selected shutter time.

For timing details, refer to fig. 18. through fig. 25.

To use this mode:

Set function:	Trigger mode	Pre-select (PS)
	Scanning	Full, Partial
	Vertical binning	ON / OFF
	Shutter mode	Preset, Programmable, Abs
	Exposure time	Shutter speed, Programmable exposure
	Other functions and settings	
Input:	Ext. trigger.	GigE interface or 12-pin Hirose

Important notes on using this mode

- Trigger pulse >1 LVAL to <1 FVAL
- The following table shows minimum trigger interval in synchronous accumulation mode

Full scan	513 L
2/3 partial	363 L
1/2 Partial	293 L
1/4 Partial	184 L
1/8 Partial	131 L
1/2 V Binning	260 L

In case of a-synchronous mode, the exposure time should be added to the above table.

LVAL_sync timing

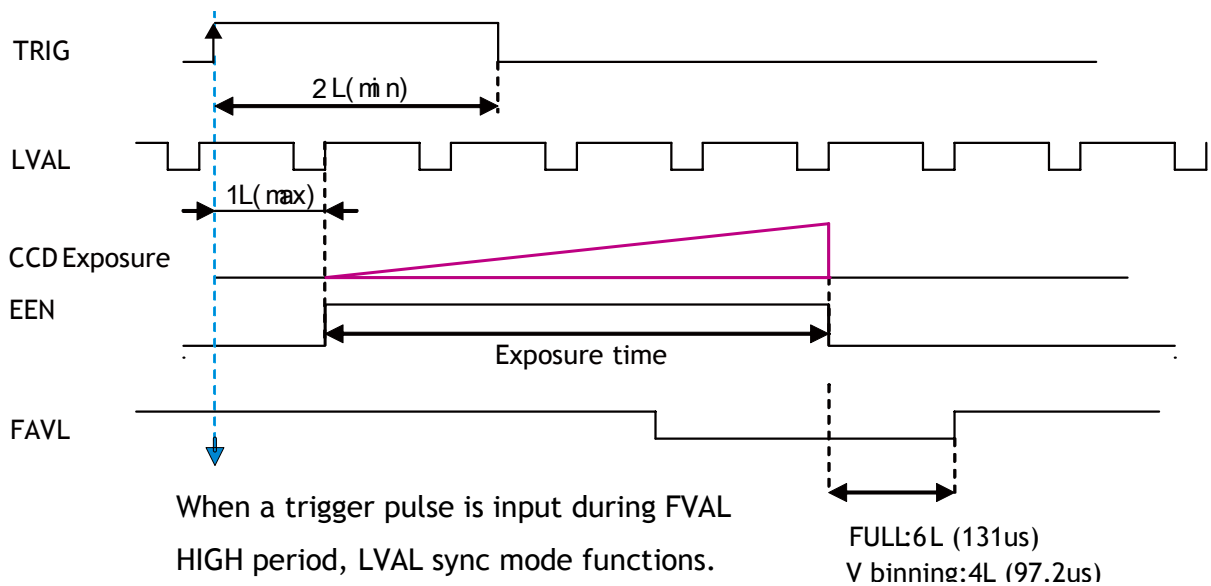

Fig. 24. Edge Pre-select LVAL sync Timing

LVAL_a-sync timing

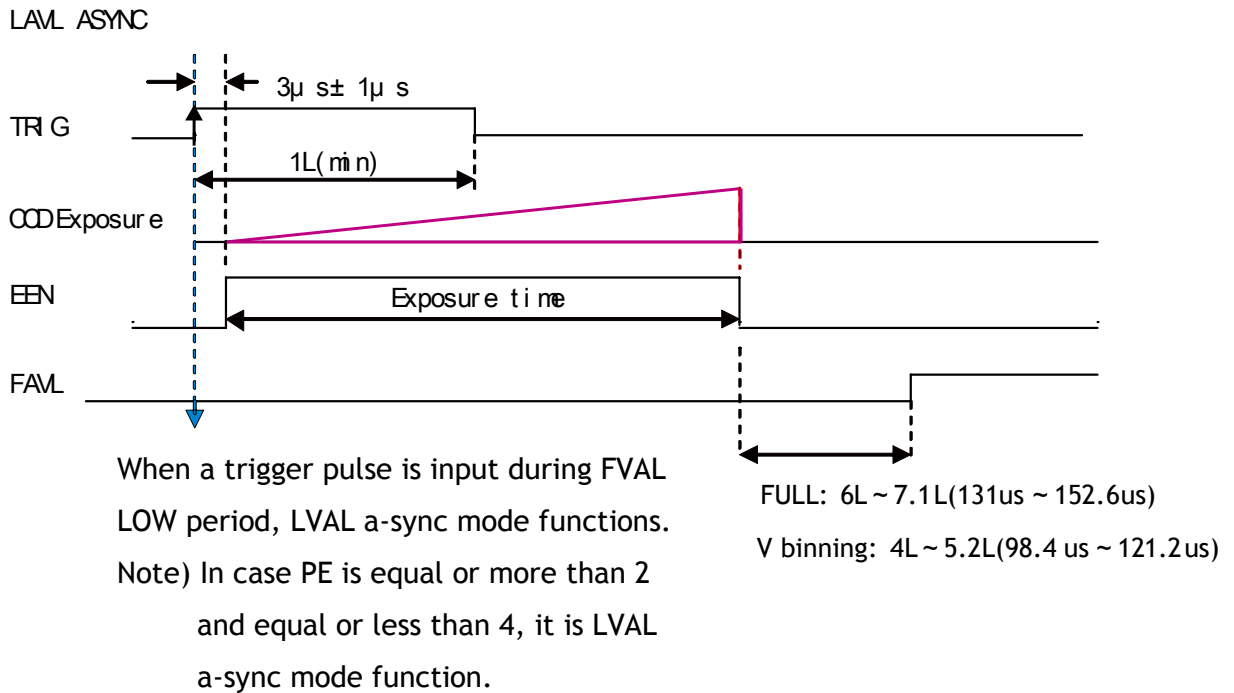

Fig.25. Edge Pre-select LVAL a-sync Timing

8.5.3 Pulse Width trigger mode

In this mode the accumulation time is equal the trigger pulse width. Here it is possible to have long time exposure. The maximum recommended time is <2 seconds. The accumulation can be LVAL synchronous or LVAL a-synchronous. The resulting video signal will start to be read out after the trigger rising edge. For timing details, refer to fig. 18. through fig. 23 and fig. 26 and 27.

To use this mode:

Set function: Trigger mode Pulse Width (PS)
 Scanning Full, Partial
 Vertical binning ON / OFF
 Other functions and settings

Input: Ext. trigger. GigE interface or 12-pin Hirose

Important notes on using this mode

- Trigger pulse width >1 LVAL to <2 seconds
- The following table shows minimum trigger interval in synchronous accumulation mode

Full scan	513 L
2/3 Partial	363 L
1/2 Partial	293 L
1/4 Partial	184 L
1/8 Partial	131 L
V Binning	260 L

In case of a-synchronous mode, the exposure time should be added to the above table.

LVAL_sync timing

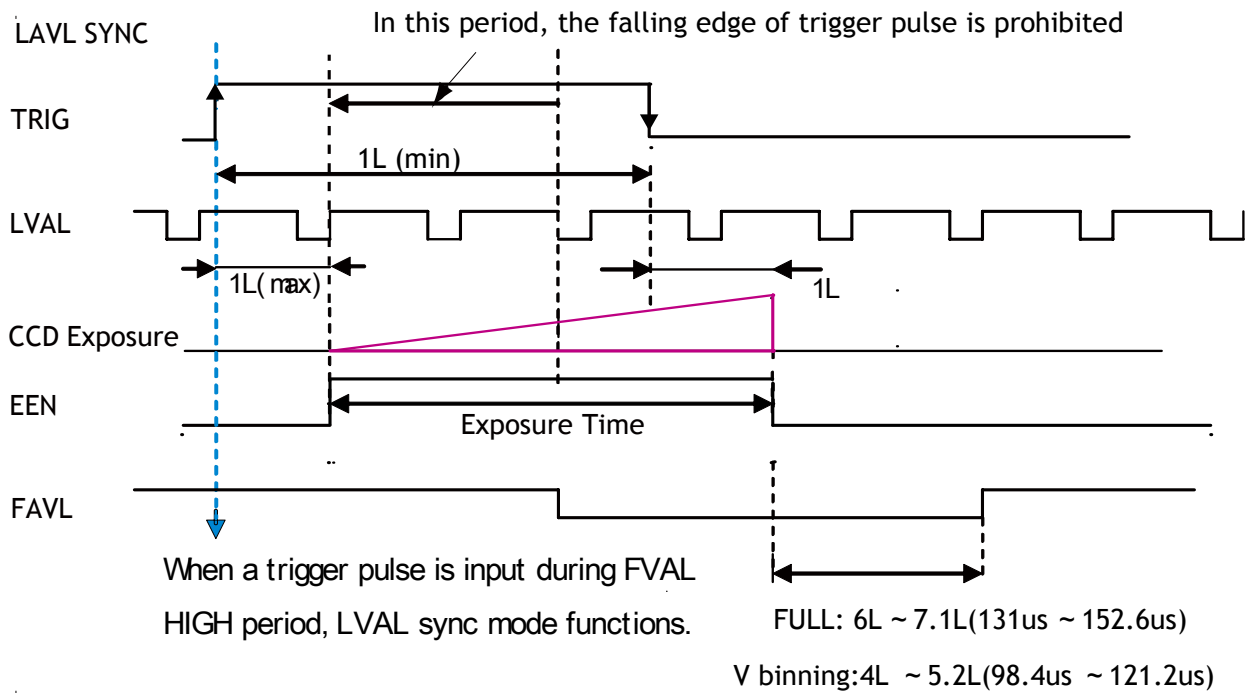

Fig. 26. Pulse width control. LVAL sync.

LVAL_a-sync timing

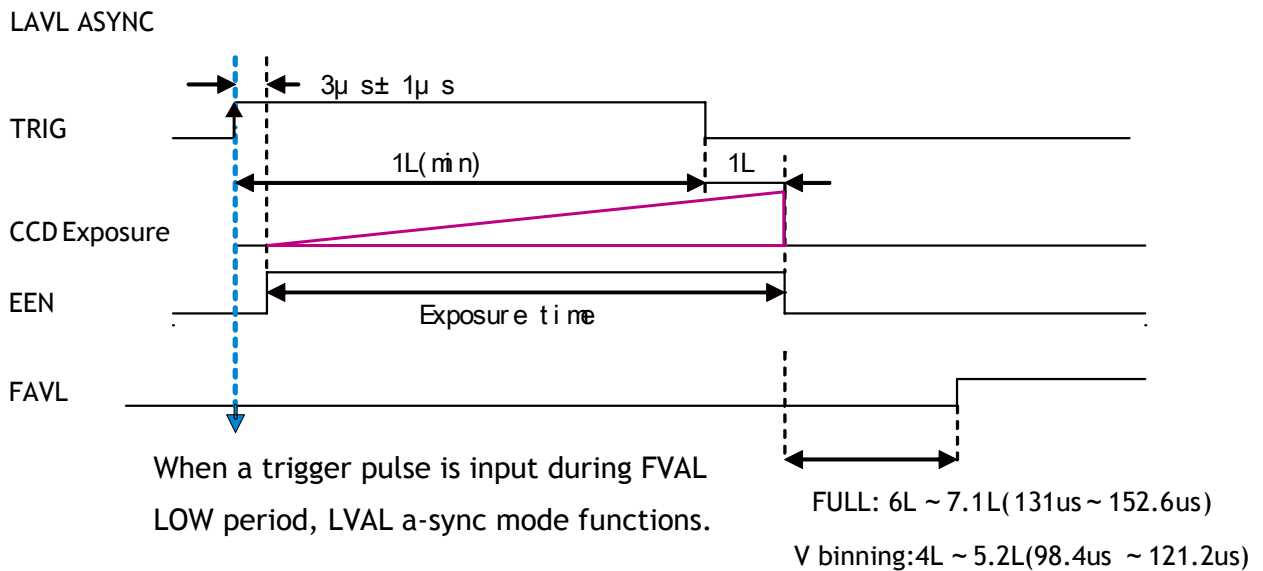
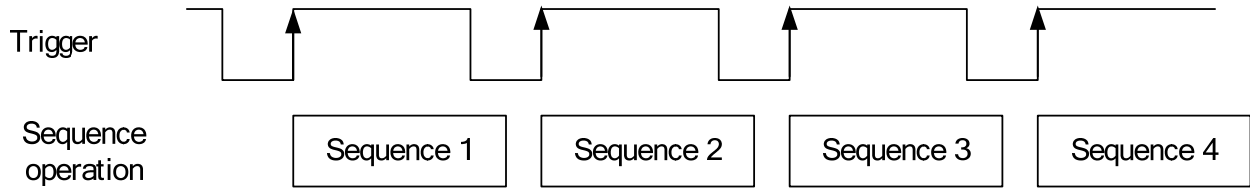

Fig.27. Pulse Width control LVAL a-sync

8.5.4 Sequential Trigger Mode (Pre-Select trigger)

The ROI, Shutter and Gain values can be preset up to 10 sequences. Along with every trigger input, the image data with the preset sequence is output as described below.



Signals added to trigger can be selected by 0xB060 Camera Trigger Selector on register map via GPIO. The camera will functions on the rising edge of the trigger and Negative or Positive should be determined accordingly.

For the sequence, the following default settings are installed.

ID	ROI				Shutter	Gain
	Width	Height	Offset X	Offset Y		
1	656	494	0	0	511	0
2	656	494	0	0	511	0
3	656	494	0	0	511	0
4	656	494	0	0	511	0
5	656	494	0	0	511	0
6	656	494	0	0	511	0
7	656	494	0	0	511	0
8	656	494	0	0	511	0
9	656	494	0	0	511	0
10	656	494	0	0	511	0

The following registers are used to configure the sequence.

- 0xC0F4 Sequence Repetitions (Number of Repetitions)
- 0xC0F8 Sequence Ending Position (Ending Position)
- 0xA30C Sequence Reset Command (1 only)
- 0xB060 Selection for camera trigger 0
- 0xA040 Trigger mode selection and 0x09 for Sequential EPS mode

Example of settings

Setting: Repeat 5 times from ID 1 through ID 8

- 0xC0F4 Set to 0x05
- 0xC0F8 Set to 0x08
- 0xB060 For instance, Pin 6 of the 12-pin Hirose connector for Opto IN 1
- 0xA040 Sequential PS (9).
- 0xA3F0 Set this for start
- 0xA040 Set Normal Mode (0) for stop

Please refer the detailed register description on Camera Register Map which is included in the SDK.

The following table shows the minimum trigger interval in synchronous accumulation mode. In case of a-synchronous accumulation mode, the exposure time should be added to figures in this table.

Full Scan	2/3Partial	1/2 Partial	1/4 Partial	1/8 Partial	1/2 V Binning
514 L	364 L	294 L	185 L	132 L	261 L

- ◆ The conditions for this table are that the shutter speed should be set the same for all sequences.
If the shutter speed is different, the difference of exposure time should be added. It is recommended to set the exposure time in the order from the shortest to the longer one.
- ◆ The minimum trigger interval is > Exposure time (expressed in L(Line)) + FVAL on Normal scan (511L) + 1L)
- ◆ Do not input the trigger just after the sequence is reset. It requires at least 500ms delay.
- ◆ On sequential mode, the exposure should be adjusted so that the LVAL a-sync mode can always be functioned.

8.5.5 Delayed Readout Mode (Pre-Select)

This mode can be used to delay the transmission of a captured image. When several cameras are triggered simultaneously and connected to the same GigE interface, it allows the cameras to be read out in sequence, preventing congestion.

The image data is not transmitted directly by the trigger 0 and it is stored in the memory located at Ethernet Interface. By the falling edge of the soft trigger 1, the image data is output.

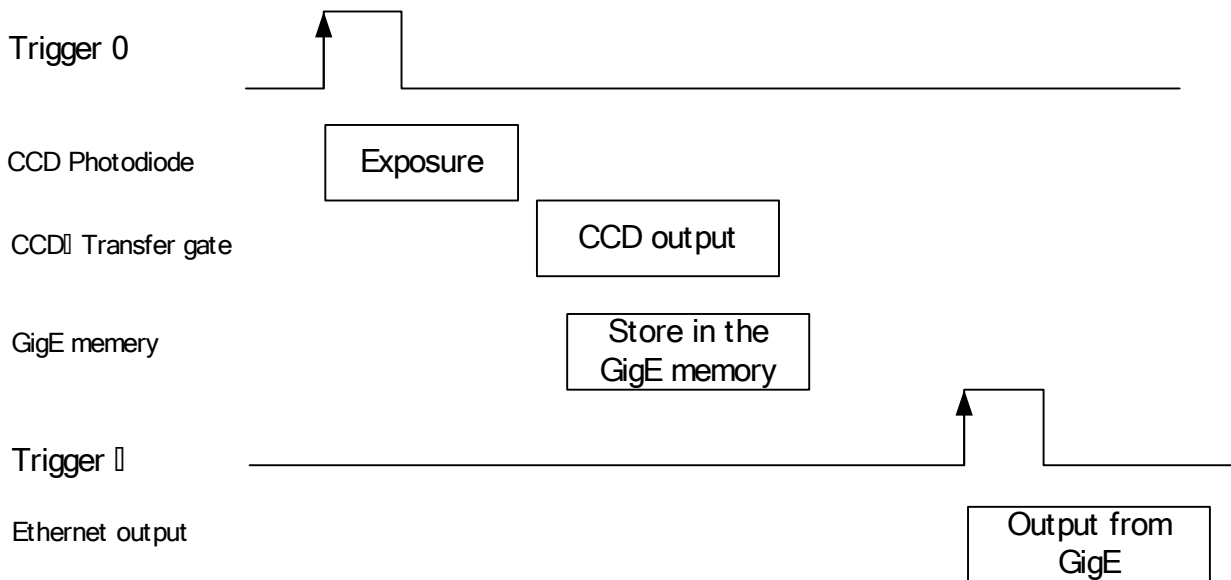

Example of setting

0xA040 EPS Delayed Readout (0x11)
 0xB060 Trigger 0 select, e.g. 0x04 OPT IN 1
 0xB-064 Trigger 1 select, e.g. 0x05 OPT IN 2

For the details of Registers, please refer Camera Register Map which is included in the SDK.

8.5.6 Optical Black transfer mode

It is possible for the user to decide whether the optical black (OB) portion of the image will be transferred or not. The optical black part can be used for black reference in the application software.

Setting register 0xA41C turns the optical black transfer ON or OFF. The default condition is OFF.

	OB Transfer Mode OFF	OB Transfer Mode ON
Normal Scan	<p>1 656</p> <p>1 494</p>	<p>1 656 672</p> <p>1 6 500</p> <p>16 pixels for Horizontal, & 6 lines for Vertical are added.</p>
2/3 Partial Scan	<p>1 656</p> <p>1 326</p>	<p>1 656 672</p> <p>1 326</p> <p>16 pixels for Horizontal are added</p>
1/2 Partial Scan	<p>1 1624</p> <p>1 246</p>	<p>1 656 672</p> <p>1 246</p> <p>16 pixels for horizontal is added.</p>
1/4 Partial Scan	<p>1 1624</p> <p>1 122</p>	<p>1 656 672</p> <p>1 122</p> <p>16 pixels for horizontal is added.</p>
1/8 Partial Scan	<p>1 1624</p> <p>1 62</p>	<p>1 56 672</p> <p>1 62</p> <p>16 pixels for horizontal is added.</p>
V Binning Scan	<p>1 1624</p> <p>1 247</p>	<p>1 656 672</p> <p>1 247</p> <p>16 pixels for horizontal is added.</p>

8.6 Operation Mode and Functions matrix

ID (Value) Note 1	Mode	Shutter Preset / Program.	Vertical Binning Note 2	Partial Scanning	LVAL Sync/Async	Auto Iris output
0x00	Continuous	Yes	Yes	Yes	---	Yes (Note 3)
0x01	Edge Pre- select (PS)	Yes	Yes	Yes	Auto	No
0x02	Pulse Width (PW)	Not applicable	Yes	Yes	Auto	No
0x09	Sequential Pre-select (PS)	Yes	Yes	Yes	Auto	No
0x11	Pre-Select Delayed Readout	Yes	Yes	Yes	Auto	No

Note 1: Write ID in register address 0xA040 in order to set trigger mode.

Note 2: Vertical Binning is available for only CM-030GE.

Note 3: Auto iris output is available only on Continuous mode with full resolution or with vertical binning. It cannot be used with partial scan mode.

9. Register Map

The below table provides detailed information for the hardware registers used for controlling the camera and obtaining information on the status of the camera. The content of this register map is also found in the XML file, as stipulated by the GenICam standard.

Generic Registers:

Address	Function	Read / Write	Size	Value / Range of value	Description	Default value
0x0000	Version	R	4	(Major, Minor) vector	Version of the GigE Standard to which the device is compliant.	
0x0004	Device mode	R	4		Information about device mode of operation.	
0x0008	Device MAC address (high)	R	4		Upper 4 bytes of the MAC address	
0x000c	Device MAC address (low)	R	4		Lower 4 bytes of the MAC address	
0x0010	IP	R	4	Bit 0: persistent Bit 1: DHCP Bit 2: LLA	Bits can be OR-ed. All other bits are reserved and set to 0. DHCP and LLA bits must be on.	
0x0014	IP address setup	R/W	4	Bit 0: persistent Bit 1: DHCP Bit 2: LLA	Bits can be OR-ed. LLA is always activated and is read only.	
0x0024	Current IP address	R	4			
0x0034	Current subnet mask	R	4			
0x0044	Current default gateway	R	4			
0x0048	Manufacturer's name	R	32		e.g. JAI	
0x0068	Model name	R	32		e.g. CM-030GE	
0x0088	Device version	R	32			
0x00A8	Manufacturer specific info	R	80		Provides extended manufacturer information about the device.	
0x00D8	Serial number	R	16		Camera serial number	
0x00E8	Camera ID	R/W	16		User assignable string	
0x0200	First choice of URL for XML	R	512		File extension .XML indicates uncompressed text file. File extension .ZIP indicates compressed using ZIP.	
0x0400	Second choice of URL for XML	R	512			
0x0600	Number of network interfaces	R	4		Indicates the number of physical network interfaces on this device.	
0x064C	persistent IP address	R/W	4		Valid if Persistent IP is enabled	
0x065C	persistent subnet mask	R/W	4		Valid if Persistent IP is enabled	
0x066C	persistent gateway	R/W	4		Valid if Persistent IP is enabled	
Address	Function	Read / Write	Size	Value / Range of value	Description	Default value

0x0900	number of messaging channels	R	4	This camera has 1	number of available message channel	
0x0904	number of stream channels	R	4	This camera only has 1	number of available stream channel	
0x0934	GVCP capability	R	4	Bit 31:multiple read Bit 30:WRITEMEM Bit29: ACKETRESE ND Bit 28:EVENT Bit 27:EVENTDATA	This is a capability register indicating which one of the non-mandatory GVCP commands are supported by this device.	
0x0938	Heartbeat timeout	R/W	4	The min. value is 500 ms	In milliseconds. Internally, the heartbeat is rounded according to the clock used for heartbeat.	0
0x093C	Timestamp tick frequency (High)	R	4	Timestamp tick frequency is 0 if timestamp is not supported.	64-bit value indicating the number of timestamp clock ticks in 1 second. This register holds the most significant bytes.	
0x0940	Timestamp tick frequency (Low)	R	4		This register holds the least significant bytes.	
0x0944	Timestamp control	W	4	Bit 0: Reset Bit 1:latch current timestamp	Used to latch the current timestamp value. No need to clear to 0.	
0x0948	Timestamp (High)	R	4		Latched value of the timestamp (most significant bytes)	
0x094C	Timestamp (Low)	R	4		Latched value of the timestamp (least significant bytes)	
0x0a00	CCP	R	4	0:Disconnect 1:Exclusive 2:Control 3:Exclusive Control	control channel privilege register	0
0x0b00	MCP	R	4		message channel port register	0
0x0b10	MCDA	R	4	Not specified	message channel destination address register	
0x0b14	MCTT	R	4		message channel transfer timeout: ms	300
0x0b18	MCRC	R	4		message channel retry count	2
0x0d00	SCPO	R	4	Not specified	primary stream port register	
0x0d04	SCPS0	R/W	4	Decided by system	primary stream channel packet size register packet size includes IP, UDP&GVSP Header	1428 XML file
0x0d08	SCPDO	R/W	4	21.6 us Max With 62.5MHz Tick Time	primary stream channel packet delay register	0
0x0d18	SCDAO	R	4	Not specified. Decided by application	primary stream channel destination address register	

CM-030 GE / CB-030 GE

Standard camera functions registers:

Address	Function	Read / Write	Size	Value / Range of value	Description	Default value
0xA000	Shutter mode	R/W	4	0= Preset shutter 1= Programmable exposure 4=Exposure TimeAbs	Sets exposure time for image capture.	0
0xA004	Preset shutter	R/W	4	0=Off; 1=1/100; 2=1/120; 3=1/250; 4=1/500; 5=1/1000; 6=1/2000; 7=1/4000; 8=1/8000; 9=1/10000	Fixed values for setting exposure	0
0xA008	Programmable exposure, PE	R/W	4	2 to 511(OFF)	Flexible setting of exposure time ranging from 43.2 μ s to 11.037 ms using the LVAL period (L) as increment. 1L is 21.6 μ s.	511
0xA018	Exposure TimeAbs (single)	R/W	4	43 to 11038 OFF)	Actual exposure time in microseconds, μ s. The camera will round value off to match LVAL increments.	11038
0xA040	Trigger Mode	R/W	4	0x00=Continuous 0x01=Edge pre-select 0x02=Pulse width control 0x09=Sequential EPS 0x11=Delayed EPS		0
0xA080	Partial Scan	R/W	4	0=Full Frame 1=2/3 Partial 2=1/2 Partial 3=1/4 Partial 4=1/8 Partial		0
0xA084	Vertical Binning	R/W	4	1=Binning OFF 2=1/2 V Binning		1
0xA0C4	Manual Gain Level	R/W	4	-84 to 336		0
0xA0E0	User Black level	R/W	4	0 to 1023 64 LSB=1023 32LSB=512 to 528		525
0xA13C	Test Stream (Jumbo Packet Check)	R/W	4	0=OFF 1=White Noise 4=H Ramp Scale 5=V Ramp Scale 6=Moving Ramp Scale CB-030GE only: 8=Color Bar 9=Color Bar 10=Moving Color Bar		0

Address	Function	Read / Write	Size	Value / Range of value	Description	Default value
0xA300	Save Settings into User area	W	4	1=User area1 2=User area2 3=User area3	Allows use to save all camera settings. Last used area number becomes new default.	1
0xA304	Load Settings	W	4	0=Factory area 1=User area1 2=User area2 3=User area3	Allow the user to recall all camera settings.	0
0xA308	EPROM current Area No.	R	4	0 to 3		0
0xA30C	Save Sequence	W	4	1 only		1

Sequence function registers:

Address	Function	Read / Write	Size	Value / Range of value	Description	Default value
0xC000	Sequence Shutter 1	R/W	4	2 to 511	Pre-program 1 st shutter value	511
0xC004	Sequence Shutter 2	R/W	4	2 to 511	Pre-program 2 nd shutter value	511
0xC008	Sequence Shutter 3	R/W	4	2 to 511	Pre-program 3 rd shutter value	511
0xC00C	Sequence Shutter 4	R/W	4	2 to 511	Pre-program 4 th shutter value	511
0xC010	Sequence Shutter 5	R/W	4	2 to 511	Pre-program 5 th shutter value	511
0xC014	Sequence Shutter 6	R/W	4	2 to 511	Pre-program 6 th shutter value	511
0xC018	Sequence Shutter 7	R/W	4	2 to 511	Pre-program 7 th shutter value	511
0xC01C	Sequence Shutter 8	R/W	4	2 to 511	Pre-program 8 th shutter value	511
0xC020	Sequence Shutter 9	R/W	4	2 to 511	Pre-program 9 th shutter value	511
0xC024	Sequence Shutter 10	R/W	4	2 to 511	Pre-program 10 th shutter value	511
0xC078	Sequence Gain 1	R/W	4	-84 to 336	Pre-program 1 st Gain value	0
0xC07C	Sequence Gain 2	R/W	4	-84 to 336	Pre-program 2 nd Gain value	0
0xC080	Sequence Gain 3	R/W	4	-84 to 336	Pre-program 3 rd Gain value	0
0xC084	Sequence Gain 4	R/W	4	-84 to 336	Pre-program 4 th Gain value	0
0xC088	Sequence Gain 5	R/W	4	-84 to 336	Pre-program 5 th Gain value	0

CM-030 GE / CB-030 GE

Address	Function	Read / Write	Size	Value / Range of value	Description	Default value
0xC08C	Sequence Gain 6	R/W	4	-84 to 336	Pre-program 6 th Gain value	0
0xC090	Sequence Gain 7	R/W	4	-84 to 336	Pre-program 7 th Gain value	0
0xC094	Sequence Gain 8	R/W	4	-84 to 336	Pre-program 8 th Gain value	0
0xC098	Sequence Gain 9	R/W	4	-84 to 336	Pre-program 9 th Gain value	0
0xC09C	Sequence Gain 10	R/W	4	-84 to 336	Pre-program 10 th Gain value	0
0xC0F0	Sequence Reset	W	4	1 only	Sequence Reset	1
0xC0F4	Sequence Mode Function 1	R/W	4	0 to 255	Number of repetition	0
0xC0F8	Sequence Mode Function 2	R/W	4	1 to 10	Ending position	1
0xC0FC	Sequence ROI size- X1	R/W	4	8 to 656		Width max
0xC100	Sequence ROI Size- X2	R/W	4	8 to 656		Width max
0xC104	Sequence ROI Size- X3	R/W	4	8 to 656		Width max
0xC108	Sequence ROI Size- X4	R/W	4	8 to 656		Width max
0xC10C	Sequence ROI size- X5	R/W	4	8 to 656		Width max
0xC110	Sequence ROI Size- X6	R/W	4	8 to 656		Width max
0xC114	Sequence ROI size- X7	R/W	4	8 to 656		Width max
0xC118	Sequence ROI Size- X8	R/W	4	8 to 656		Width max
0xC11C	Sequence ROI size- X9	R/W	4	8 to 656		Width max
0xC120	Sequence ROI Size- X10	R/W	4	8 to 656		Width max
0xC124	Sequence ROI Size-Y1	R/W	4	8 to 494		Height Max
0xC128	Sequence ROI Size-Y2	R/W	4	8 to 494		Height Max
0xC12C	Sequence ROI Size-Y3	R/W	4	8 to 494		Height Max
0xC130	Sequence ROI Size-Y4	R/W	4	8 to 494		Height Max
0xC134	Sequence ROI Size-Y5	R/W	4	8 to 494		Height Max
0xC138	Sequence ROI Size-Y6	R/W	4	8 to 494		Height Max
0xC13C	Sequence ROI Size-Y7	R/W	4	8 to 494		Height Max
0xC140	Sequence ROI Size-Y8	R/W	4	8 to 494		Height Max

Address	Function	Read / Write	Size	Value / Range of value	Description	Default value
0xC144	Sequence ROI Size-Y9	R/W	4	8 to 494		Height Max
0xC148	Sequence ROI Size-Y10	R/W	4	8 to 494		Height Max
0xC14C	Sequence ROI Offset-X1	R/W	4	0 to 648		0
0xC150	Sequence ROI Offset-X2	R/W	4	0 to 648		0
0xC154	Sequence ROI Offset-X3	R/W	4	0 to 648		0
0xC158	Sequence ROI Offset-X4	R/W	4	0 to 648		0
0xC15C	Sequence ROI Offset-X5	R/W	4	0 to 648		0
0xC160	Sequence ROI Offset-X6	R/W	4	0 to 648		0
0xC164	Sequence ROI Offset-X7	R/W	4	0 to 648		0
0xC168	Sequence ROI Offset-X8	R/W	4	0 to 648		0
0xC16C	Sequence ROI Offset-X9	R/W	4	0 to 648		0
0xC170	Sequence ROI Offset-X10	R/W	4	0 to 648		0
0xC174	Sequence ROI Offset-Y1	R/W	4	0 to 486		0
0xC178	Sequence ROI Offset-Y2	R/W	4	0 to 486		0
0xC17C	Sequence ROI Offset-Y3	R/W	4	0 to 486		0
0xC180	Sequence ROI Offset-Y4	R/W	4	0 to 486		0
0xC184	Sequence ROI Offset-Y5	R/W	4	0 to 486		0
0xC188	Sequence ROI Offset-Y6	R/W	4	0 to 486		0
0xC18C	Sequence ROI Offset-Y7	R/W	4	0 to 486		0
0xC190	Sequence ROI Offset-Y8	R/W	4	0 to 486		0
0xC194	Sequence ROI Offset-Y9	R/W	4	0 to 486		0
0xC198	Sequence ROI Offset-Y10	R/W	4	0 to 486		0

CM-030 GE / CB-030 GE

GigE Vision streaming related registers:

Address	Function	Read / Write	Size	Value / Range of value	Description	Default value
0xA400	Horizontal Image Size	R	4		return proper value when normal, V-bin & partial	
0xA404	Vertical Image Size	R	4		return proper value when normal, V-bin & partial	
0xA410	Video Pixel Format Type	R/W	4	0x01080001 0x010C0004 0x01100003 0x01080009 0x0108000A 0x0110000D 0x0110000E	Mono8 Mono 10 Packed Mono10 BAYRG8 BAYGB8 BAYRG10 BAYGB10	Mono8 for CM-030GE / BAYGB8 for CB-030GE
0xA414	Frame Skipping Ratio	R/W	4	0=STD(30fps) 1=STD/2 2=STD/4 3=STD/8		0
0xA418	Payload Length register	R/W	4	Number of bytes in a frame		
0xA41C	OB Trans Mode	R/W	4	0= OFF 1= ON		0
0xA504	ROI1 Size X	R/W	4	8 to 656	Width	W.Max
0xA508	ROI1 Size Y	R/W	4	8 to 494	Height	H.Max
0xA50C	ROI1 Offset X	R/W	4	0 to 648	Horizontal offset	0
0xA510	ROI1 Offset Y	R/W	4	0 to 486	Vertical offset	0
0xA600	Soft Trigger 0	R/W	4	0=LOW 1=HIGH		0
0xA604	Video Sending Flag	R/W	4	0=Off, 1=On		0
0xA610	Event ON/OFF register	R/W	4	Bit 31:GEV_EVENT_TRIGGER		0
				Bit30:GEV_EVENT_START_OF_EXPOSURE		0
				Bit29:GEV_EVENT_END_OF_EXPOSURE		0
				Bit28:GEV_EVENT_START_OF_TRANSFER		0
				Bit27:GEV_EVENT_END_OF_TRANSFER		0
0xA640	Camera Reset (from Genlcam)	w	4	0=OFF 1=Reset		0
0xA644	Soft Trigger 1	R/W	4	0=LOW, 1=HIGH		0
0xA648	Soft Trigger 2	R/W	4	0=LOW, 1=HIGH		0



0xA64C	Soft Trigger 3	R/W	4	0=LOW, 1=HIGH		0
0xA714	FPGA version	R	4			

CM-030 GE / CB-030 GE

GPIO Registers:

Address	Function	Read / Write	Size	Value / Range of value	Description	Default value
0xB000	Counter Clock source	R/W	4	0x00 0x01	25MHz Pixel Clock	0
0xB004	Counter Divide by Value	R/W	4	0x000 0x001 0x002 0xFFFF	Bypass Divide by 2 Divide by 3 Divide by 4096	0
0xB008	Length Counter 0	R/W	4	0x00001 to 0xFFFFF	Defines the length of the counter	1
0xB00C	Start point Counter 0 (1)	R/W	4	0x00001 to 0xFFFFF	Defines the starting point of the counter	0
0xB010	Start point Counter 0(2)	R/W	4	0x00: infinite 0x01: 1 time 0xFF: 255 times	Defines the number of repeats (loops)	0
0xB014	End point Counter 0	R/W	4	0x00001 to 0xFFFFF	Defines the end point of the counter	1
0xB018	Counter 0 Clear	R/W	4	0 1 2 4 8	Free Run High Level Clear Low Level Clear Rising Edge Clear Falling Edge Clear	0
0xB01C	Length Counter 1	R/W	4	0x00001 to 0xFFFFF	Counter length	1
0xB020	Start point Counter 1(1)	R/W	4	0x00001 to 0xFFFFF	Start Point	0
0xB024	Start point Counter 1(2)	R/W	4	0x00: infinite 0x01: 1 time 0xFF: 255 times	Repeat Count	0
0xB028	End point Counter 1	R/W	4	0x00001 to 0xFFFFF	End point	1
0xB02C	Counter 1 Clear	R/W	4	0 1 2 4 8	Free Run High Level Clear Low Level Clear Rising Edge Clear Falling Edge Clear	0
0xB030	Length Counter 2	R/W	4	0x00001 to 0xFFFFF	Counter length	1
0xB034	Start point Counter 2 (1)	R/W	4	0x00001 to 0xFFFFF	Start Point	0
0xB038	Start point Counter 2 (2)	R/W	4	0x00: infinite 0x01: 1 time 0xFF: 255 times	Repeat Count	0

Address	Function	Read / Write	Size	Value / Range of value	Description	Default value	
0xB03C	End point Counter 2	R/W	4	0x00001 to 0xFFFFF	End point	1	
0xB040	Counter 2 Clear	R/W	4	0 1 2 4 8	Free Run High Level Clear Low Level Clear Rising Edge Clear Falling Edge Clear	0	
0xB044	Length Counter 3	R/W	4	0x00001 to 0xFFFFF	Counter length	1	
0xB048	Start point Counter 3(1)	R/W	4	0x00001 to 0xFFFFF	Start Point	0	
0xB04C	Start point Counter 3(2)	R/W	4	0x00: infinite 0x01: 1 time 0xFF: 255 times	Repeat Count	0	
0xB050	End point Counter 3	R/W	4	0x00001 to 0xFFFFF	End point	1	
0xB054	Counter 3 Clear	R/W	4	0 1 2 4 8	Free Run High Level Clear Low Level Clear Rising Edge Clear Falling Edge Clear	0	
0xB060	Selector CAMERA TRIGGER 0	R/W	4	GPIO Selector: 0x00:CAMERA LVAL IN 0x01:CAMERA DVAL IN 0x02:CAMERA FVAL IN 0x03:CAMERA EEN IN 0x04:OPT IN 1 0x05:OPT IN 2 0x0C:SOFT TRIG 0 0x0D:SOFT TRIG 1 0x0E:SOFT TRIG 2 0x0F:SOFT TRIG 3 0x10:Pulse Gen. 0 0x11:Pulse Gen. 1 0x12:Pulse Gen. 2 0x13:Pulse Gen. 3 0x7F:No Connection	For Camera Trigger	127	
0xB064	Selector CAMERA TRIGGER 1	R/W	4		For Delayed Trigger		
0xB070	Selector GPIO PORT 1	R/W	4		Optical out 1		
0xB074	Selector GPIO PORT 2	R/W	4		Optical Out 2		
0xB090	Selector Pulse Generator 0	R/W	4				
0xB094	Selector Pulse Generator 1	R/W	4				
0xB098	Selector Pulse Generator 2	R/W	4				
0xB09C	Selector Pulse Generator 3	R/W	4				
0xB0A0	Selector Time Stamp Reset	R/W	4		Add 0x80 will result in low active output.		

10. External Appearance and Dimensions

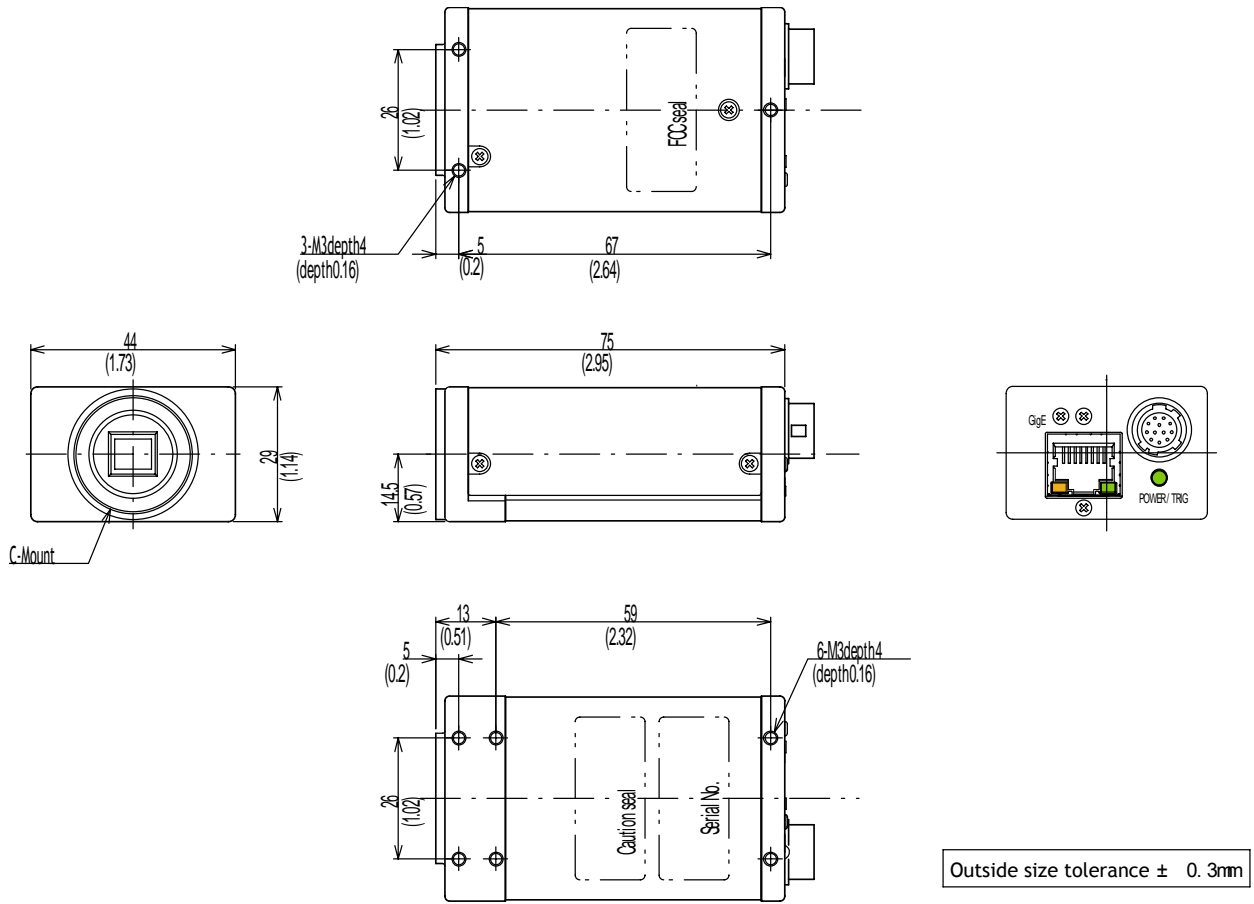

Fig. 28. Outline.

11. Specifications

11.1 Spectral response

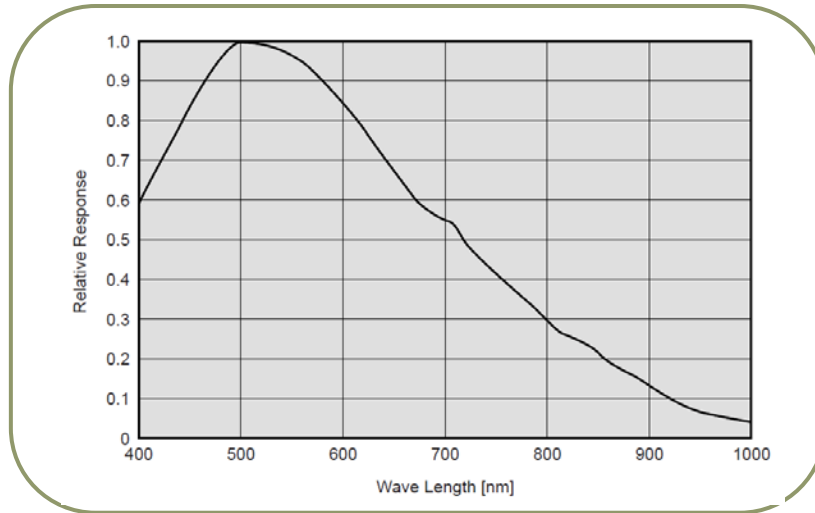

Fig. 29. Spectral response for CM-030GE

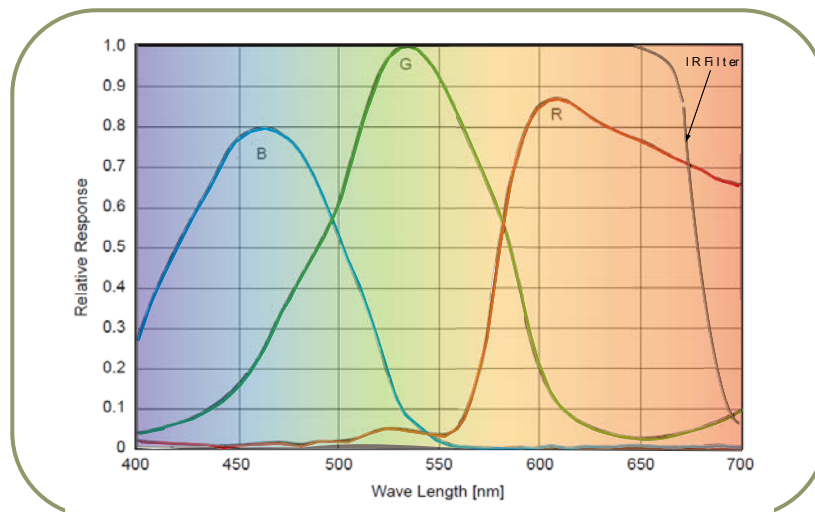

Fig.30. Spectral response for CB-030GE

CM-030 GE / CB-030 GE

11.2 Specification table

Specifications	CM-030GE	CB-030GE
Scanning system	Progressive scan	
Frame rate full frame	90.5 frames/sec. Progressive (511 lines/frame)	
Pixel clock	40 MHz	
Line frequency	46.296 kHz (1H = 21.6 μ s), (864 pixel clock/line)	
CCD sensor	1/3". Monochrome ICX424AL	1/3" Bayer Color ICX424AQ
Sensing area	4.85 (h) x 3.66 (v) mm 1/3 inch diagonal	
Cell size	7.4 (h) x 7.4 (v) μ m	
Active pixels	656 (h) x 494 (v)	
Pixels in video output. Full Scan 2/3 partial Scan 1/2 partial Scan 1/4 partial Scan 1/8 partial Scan Vertical Binning Region-of-interest (ROI)	656 (h) x 494 (v) 90.5 fps. H = 46.296 kHz 656(h) x 326 (v) 128 fps H= 46.296kHz 656 (h) x 246 (v) 159 fps. H = 46.296 kHz 656 (h) x 122 (v) 255 fps. H = 46.296kHz 656 (h) x 62 (v) 361 fps. H = 46.2965 kHz 656 (h) x 247 (v) 166.2 fps. H = 42.735 kHz (*Note) User Definable. Memory read-out *Note: Vertical binning is for CM-030GE only	
Sensitivity on sensor (minimum)	0.004 Lux (Max. gain, Shutter OFF, 50% video)	1.21 Lux (Max. gain, Shutter OFF, 50% Green, w/IR cut filter)
S/N ratio	More than 50 dB (0dB gain)	
Digital Video output.	GigE Vision Compliant Mono8, Mono10, Mono10_Packed	GigE Vision Compliant BAYRG8, BAYGB8, BAYRG10, BAYGB10
Iris video output. Analogue	0.7 V p-p , enabled by internal switch	
Gain	Manual -3 to +12 dB	
Synchronization	Internal X-tal	
GPIO Module Input/output switch Clock Generator (One) Pulse Generators (Four)	Configurable 14-in / 9-out switch 12-bit counter based on 25MHz clock or Pixel clock 20-bit counter programmable for length, start point, stop point, repeat	
Hardware Trigger modes	Edge Pre-Select , Pulse Width Control, Frame Delay and Sequence	
OB area transfer mode	ON / OFF	
Event message	SYNC / ASYNC mode (Trigger mode status when exposure starts) Exposure start, Exposure end, Trigger IN, Video start, Video end	
Electronic Shutter Preset Shutter speed Programmable exposure Exposure Time (Abs) GPIO plus Pulse Width	OFF(1/90) and 1/100 to 1/10,000 in 9 steps 2L(43.2 μ s) to 511L (11.037ms) in 1L steps μ sec - user definable. Same range as PE max. 2 sec (Can be set by 100 μ s unit or Pixel Clock unit)	
Control interface	Register based. GigE Vision / Genlcam compliant	
Functions controlled via GigE Vision Interface	Shutter, Gain, Black Level, Trigger mode, Read out mode, GPIO setup ,ROI (Genlcam mandatory functions)	
GigE Vision Streaming Control	Packet size, Delayed (Frame) read-out, inter-packet delay Jumbo frame can be set at max. 4K(4040) , Default packet size is 1428 Byte.	
Indicators on rear panel	Power, Hardware trigger, GigE Link, GigE activity	
Operating temperature	-5°C to +45°C	
Humidity	20 - 90% non-condensing	
Storage temp/humidity	-25°C to +60°C/20% to 90% non-condensing	
Vibration	10G (20Hz to 200Hz, XYZ)	
Shock	70G	
Regulatory	CE (EN61000-6-2 and EN61000-6-3), FCC part 15 class B, RoHS, WEEE	
Power	12V DC \pm 10%. 3.6 w	
Lens mount	C-mount, Rear protrusion on C-mount lens must be less than 10.0mm	

IR-cut & Optical Low Pass Filter	Built in (only for CB-030GE)	
Dimensions	29 x 44 x 75 mm (HxWxD)	
Weight	125 g	125 g

For stable operation within the above specifications, allow approximately 30 minutes warm up.

Note: Above specifications are subject to change without notice

12. Appendix

Precautions

Personnel not trained in dealing with similar electronic devices should not service this camera.

The camera contains components sensitive to electrostatic discharge. The handling of these devices should follow the requirements of electrostatic sensitive components.

Do not attempt to disassemble this camera.

Do not expose this camera to rain or moisture.

Do not face this camera towards the sun, extreme bright light or light reflecting objects, including laser sources.

When this camera is not in use, put the supplied lens cap on the lens mount.

Handle this camera with the maximum care.

Operate this camera only from the type of power source indicated on the camera.

Remove power from the camera during any modification work, such as changes of jumper and switch settings.

Typical Sensor Characteristics

The following effects may be observed on the video monitor screen. They do not indicate any fault of the camera, but do associate with typical sensor characteristics.

V. Aliasing

When the camera captures stripes, straight lines or similar sharp patterns, jagged image on the monitor may appear.

Blemishes

All cameras are shipped without visible image sensor blemishes.

Over time some pixel defects can occur. This does not have a practical effect on the operation of the camera. These will show up as white spots (blemishes).

Exposure to cosmic rays can cause blemishes to appear on the image sensor. Please take care to avoid exposure to cosmic rays during transportation and storage. It is recommended using sea shipment instead of air flight in order to limit the influence of cosmic rays to camera.

Pixel defects/blemishes also may emerge due to prolonged operation at elevated ambient temperature, due to high gain setting or during long time exposure. It is therefore recommended to operate the camera within its specifications.

Patterned Noise

When the sensor captures a dark object at high temperature or is used for long time integration, fixed pattern noise may appear in the image.

Caution when mounting a lens on the camera

When mounting a lens on the camera dusts particles in the air may settle on the surface of the lens or the image sensor of the camera. It is therefore important to keep the protective caps on the lens and on the camera until the lens is mounted. Point the lens mount of the camera downward to prevent dust particles from landing on the optical surfaces of the camera. This work should be done in a dust free environment. Do not touch any of the optical surfaces of the camera or the lens.

Exportation

When exporting this product, please follow the export regulation of your own country.

References

1. This manual can for CM-030GE / CB-030GE can be downloaded from www.jai.com
2. Datasheet for CM-030GE / CB-030GE can be downloaded from www.jai.com
3. Camera control software can be downloaded from www.jai.com
4. Specifications for the CCD sensor Sony ICX-424AL and ICX-424AQ can be found on www.jai.com

Index

A		L	
Auto Iris Lens.....	- 24 -	Lens mount	- 50 -
		LVDS	- 6 -
B		N	
Bayer mosaic color	- 3 -	Network Interface Cards.....	- 18 -
Bayer mosaic filter	- 3 -		
Bit Allocation.....	- 15 -, - 16 -	P	
Blemishes	- 51 -	partial scan	- 3 -, - 27 -
		Partial scanning.....	- 27 -
C		Pin Assignment	- 6 -
CAMERA TRIGGER.....	- 10 -	Pixel Type.....	- 15 -, - 16 -
Cat6 Ethernet	- 18 -, - 19 -	Pixels in video output	- 49 -
CCD sensor.....	- 5 -, - 49 -, - 52 -	Preset Shutter.....	- 49 -
CCD Sensor	- 25 -	Programmable exposure.....	- 4 -
continuous.....	- 18 -, - 22 -, - 26 -, - 27 -, - 29 -	<i>Progressive scan</i>	- 3 -
Continuous operation	- 4 -	Pulse Generators.....	- 7 -, - 8 -
		Pulse width control(PWC)	- 22 -
D		R	
Delayed Readout Mode	- 18 -, - 34 -	Register	- 13 -, - 14 -, - 22 -, - 34 -
		RJ-45.....	- 6 -
E		ROI	- 33 -
Edge pre-select(EPS).....	- 22 -	S	
Electronic Shutter	- 23 -	SDK.....	- 3 -, - 23 -, - 34 -
EPS	- 13 -, - 14 -	Sequential trigger	- 22 -
Exposure Time Abs	- 23 -	Software Development Kit	See SDK
external trigger	- 25 -	Spectral response.....	- 48 -
External trigger	- 4 -	Switches/Routers	- 18 -
		Synchronization	- 49 -
G		T	
Gain.....	- 49 -	transmission bandwidth.....	- 18 -
GenICam.....	- 23 -	Trigger input	- 5 -, - 24 -
Gigabit Ethernet.....	- 6 -	Trigger mode	- 29 -, - 30 -, - 31 -
GigE Vision compliant.....	- 3 -, - 18 -		
GigE Vision Streaming Protocol	- 15 -, - 16 -	V	
GPIO	- 6 -, - 7 -, - 10 -, - 24 -, - 33 -, - 46 -	Vertical Binning	- 22 -, - 28 -
GPIO programming examples	- 13 -		
H		X	
Hirose	- 6 -, - 18 -, - 31 -	XML.....	- 3 -
Host-based color interpolation.....	- 3 -		
I			
Inter-Packet Delay	- 18 -		



13. User's Record

Camera type: CM-030GE / CB-030GE

Revision:

Serial No.

Firmware version.

For camera revision history, please contact your local JAI distributor.

User's Mode Settings.

User's Modifications.



DECLARATION OF CONFORMITY
 AS DEFINED BY THE COUNCIL DIRECTIVE
 89/336/EEC
 EMC (ELECTROMAGNETIC COMPABILITY)
 WE HEREWITH DECLARE THAT THIS PRODUCT
 COMPLIES WITH THE FOLOWING PROVISIONS APPLYING TO IT.
 EN61000-6-2
 EN61000-6-3

Company and product names mentioned in this manual are trademarks or registered trademarks of their respective owners. JAI A-S cannot be held responsible for any technical or typographical errors and reserves the right to make changes to products and documentation without prior notification.

Europe, Middle East & Africa

Phone +45 4457 8888

Fax +45 4491 8880

Asia Pacific

Phone +81 45 440 0154

Fax +81 45 440 0166

Americas

Phone (toll-free) +1 800 445 5444

Phone +1 408 383 0300

Visit our web site at www.jai.com



See the possibilities