

GENERAL PRODUCT INFORMATION

Une version française de cette notice est disponible sur la page à partir de la page 10 de ce document

Thank you for purchasing an Efflux's product. To ensure proper use of the product, please read this *User manual* before use and keep it for your future reference. Any improper use voids the warranty. This product is an LED light used for machine vision and industrial inspection. Do not use the product for other applications, and be sure to follow the instructions below.

Datasheets and drawings in PDF and/or CAD can be downloaded from the Efflux website: www.ffmpeg.com

The label(s) on the product always indicate(s) the reference, the power consumption and the serial number of the product. Be sure to check the content before using the product and handle the label(s) with care. The date of manufacturing is included in the serial number of the product: XXXXXYYMM-ZZZ with YY corresponding to the year and MM to the month. If the label is missing or damaged and the content cannot be checked, please contact Efflux.

GENERAL WARNINGS AND PRECAUTIONS OF USE

MAINTENANCE

The product must be switch off during any maintenance operation. To remove marks on the lens or on the window: Use alcohol-free lens cleaning fluid on a cleaning tissue. Few drops will suffice. Please clean gently. Always apply the fluid to a tissue rather than the lens itself. To clean optical components: Please wear gloves and use compressed air if there is dust.

USAGE AND STORAGE ENVIRONMENT

Operating environment	Temperature: 0 to 40°C - Humidity: 20 to 85RH% (without condensation) - Altitude: Up to 2000m
Storage environment	Temperature: -20 to 60°C - Humidity: 20 to 85RH% (without condensation)
Informations	Overvoltage category I - Protective class III - Pollution degree 3

Except if a specific IP rating is given for your product (refer to the «Dust and Water resistance (IP rating) » section), please install the product to locations with following conditions (Incorrect installation location may causes product failure) :

Well-ventilated places with minimal dust.	Places free from any liquid, chemical product or steam.
Places free from corrosive or combustible gas.	Places that are not subject to sudden temperature changes.
Places away from water taps, boilers, humidifiers, air conditioners, heaters or stoves.	

USER SECURITY

Incorrect use of the product may result in fire, electric shock, or other serious damages. Please ensure to follow below conditions. If an abnormal condition occurs (fuming, heat, noises, etc.), stop using the product immediately and turn the power off.

Do not disassemble or modify the product.	Do not look directly at the LED light without protection.
Do not try to fix any damages on the product by yourself.	Make sure special protective glasses are used with UV products (<420nm).
Do not touch the product with wet hands.	Do not use homemade cables.
Wire and keep the flying leads cables in a dry area (regardless of the product's degree of protection).	Make sure the product does not show any moisture or liquid inside before switching it ON.
Make sure the power supply and the cable/connector are adapted to the product specifications.	The device must be powered by a 24V safety power supply in accordance to local Electrical Safety rules
Do not inverse electrical polarity - check your connections and the conventions.	The product packaging must be removed before use.

PART NUMBERING

STANDARD VERSION

EFFI-FLEX2	- ...	- XXXX	- ZZZ	- WW	- PP
	LED Density	Optical Length [mm]	Wavelength [nm]	Window	Lens position
	Ø (Standard if not specified)	60	● 405 (UV)	TR (Lightly-diffuse)	P0 (90°)
	X2 (LED density x2)	100	● 465 (Blue)	SD (Semi-diffuse)	P1 (45°)
	L2 (LED density ÷2)	200	● 525 (Green)	OP (Opaline)	P2 (25°)
	L4 (LED density ÷4)	300	● 625 (Red)		P3 (10°)
		... All 100mm	● 850 (Infrared)		
		2900	○ 000 (White)		

AVAILABLE OPTIONS: REFERENCES

Please refer to the datasheet for the specifications of a product with option(s).

OPTICS	
Kit with all diffusers	EFFI-FLEX2-XXXX-ZZZ-KIT The light will be delivered as a package including TR, SD and OP windows, and assembled in the default configuration with the lens plate positioned at P2 and the SD diffuser. Only available for sizes ≤ 800mm.
Polarizer accessory	EFFI-FLEX2-XXXX-ZZZ-WW-PP-POL
UV Wavelength 365nm	EFFI-FLEX2-XXXX-365-TR-P0
Linescan film	EFFI-FLEX2-XXXX-ZZZ-TR-P3-LS
Cylindrical lens	EFFI-FLEX2-XXXX-ZZZ-TR-P1-LS-CYL
ELECTRONICS	
Specific continuous mode configurations	EFFI-FLEX2-XXXX-ZZZ-WW-PP-ELS-UUU-VVV
Customized software	EFFI-FLEX2-XXXX-ZZZ-WW-PP-SWxxxxxx Specific reference xxxxxx for each customized software
CONNECTORS	
Connector position and orientation, Cables position	EFFI-FLEX2-XXXX-ZZZ-WW-PP-SCXXX/OSC/BSC/SCG

*YY = Type of outlet UK, CH, EU, US, ...

AVAILABLE ACCESSORIES

Please refer to the specific documentations for additional information on the accessories of the EFFI-Flex2.

WINDOWS	Lightly-diffuse: EFFO-FLEX2-TR-XXXX Semi-diffuse: EFFO-FLEX2-SD-XXXX Opaline: EFFO-FLEX2-OP-XXXX	
POLARIZER	EFFO-FLEX2-POL-XXXX	
POWER SUPPLIES	Power supply: EFFI-PWR-WWW-24V-102-YY* Compact power supply: EFFI-SPWR-090W-24V-102-YY**	
CABLE with FLYING LEADS	With connector M12 - 5 pins	With connector M12P - 4 pins
	2 meters: EFFC-CAB-M12-F-5-D-L2 5 meters: EFFC-CAB-M12-F-5-D-L5 10 meters: EFFC-CAB-M12-F-5-D-L10	2 meters: EFFC-CAB-M12P-F-4-D-L2 5 meters: EFFC-CAB-M12P-F-4-D-L5 10 meters: EFFC-CAB-M12P-F-4-D-L10
EXTENSION CABLES	With connector M12 - 5 pins	With connector M12P - 4 pins
	2 meters: EFFC-CAB-M12-FM-5-DD-L2 5 meters: EFFC-CAB-M12-FM-5-DD-L5 10 meters: EFFC-CAB-M12-FM-5-DD-L10	2 meters: EFFC-CAB-M12P-FM-4-DD-L2 5 meters: EFFC-CAB-M12P-FM-4-DD-L5 10 meters: EFFC-CAB-M12P-FM-4-DD-L10
FASTENERS	T-Nut Kit: EFFV-BOLT-0011 Pivot joint Kit: EFFM-1-0002	
CAMERA FILTERS	EFFO-FLR-...	

ELECTRICAL INSTALLATION - STD CONNECTOR CONFIGURATION

POWER SUPPLY

Power Supply		24V DC (+/-10%)			
Connector(s) <i>(See wiring layout page 4)</i>	Optical length	60mm - 400mm	500mm - 1500mm	1600mm - 2900mm	
	Type	M12 (A-coded) - 5 pins	M12 Power (T-coded) - 4 pins	2x M12 Power (T-coded) - 4 pins	
Power Consumption*	Peak	Max. 30W per 100 mm			
	Average	Max. 10W per 100mm			
Built-in driver version	Multimode (3 modes: AutoStrobe with overdrive intensity / Adjustable strobe / Dimmable continuous)				
Analog Intensity Control (AIC)	The output optical power is adjustable from 10% to 100% by applying a signal from [1.5V-10VDC] Total voltage range [1.5V-24VDC] / Don't exceed 24V DC / Max. signal consumption: 4mA				
Autostrobe	450% Overdrive during 245 ms max then continuous at 100%				
	Max. duty cycle 30%				
	PNP trigger input: Light ON from 4.5V* to 24V / Don't exceed 24VDC / Max. signal consumption: 4mA <i>(Option NPN for size ≥ 500mm, on PIN4: Light ON from 0V to 1V / Don't exceed 24V DC / Max. signal consumption: 4mA)</i>				
Response time	Max. 10µs (Rise time included)				

***Note 1:** The consumption values are maximum values, the exact power consumption of the product is always indicated on the product label.

****Note 2:** The PNP threshold voltage of 4.5V may vary with cable lengths and power consumption. Please refer to the following table.

Max. PNP voltage threshold (V)														
Cable length	Max. power consumption during overdrive in AutoStrobe mode													
	20W	30W	40W	60W	80W	100W	120W	145W	170W	220W	270W	320W	370W	420W
2m	4.3	4.4	4.4	4.5	4.6	4.6	4.4	4.5	4.5	4.6	4.6	4.7	4.8	4.9
5m	4.5	4.5	4.6	4.8	5.0	5.2	4.7	4.8	4.9	5.0	5.2	5.4	5.6	5.8
10m	4.6	4.8	5.0	5.4	5.8	6.3	5.1	5.3	5.5	5.9	6.3	6.8	7.4	8.1
15m	4.8	5.1	5.4	6.0	6.8	7.7	5.6	5.9	6.2	6.9	7.9	9.2		
20m	5.0	5.4	5.8	6.8	8.1		6.1	6.5	7.1	8.4				

M12 - 5 pins	M12P - 4 pins
--------------	---------------

HOW TO CONNECT THE EFFI-FLEX2 ?

Depending, the product length, the EFFI-Flex2 comes with one M12 connector 5 pins or M12 Power 4 pins or two M12 Power connectors 4 pins. (See the table with power consumption and connector definition below)

M12 (A-coded)- 5 pins

male connector

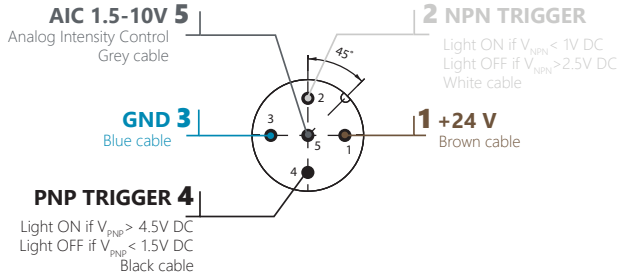

M12 Power (T-coded) - 4 pins

male connector

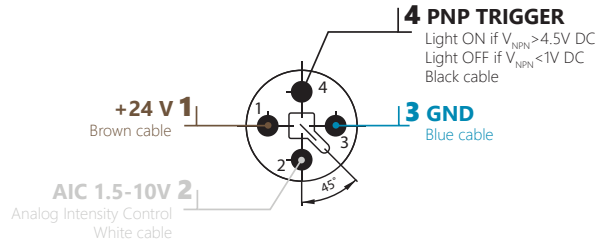

Notes:

- The EFFI-FLEX2 requires 24V DC input power.
- PNP trigger pin (or NPN) needs to be connected either to a trigger signal for AutoStrobe and Strobe mode or to a continuous signal for Continuous mode. (See Multimode driver guide on the following page)
- For light requiring M12P connector, the NPN trigger is optional. If NPN option, the PNP trigger input is replaced by the NPN trigger input. (See Multimode driver guide with NPN in Annex page 10)

POWER CONSUMPTION AND CONNECTOR DEFINITION

MAX POWER CONSUMPTION (+/- 5%) (White LED - Standard software - Duty cycle 30%)															
Optical Length XXXX (mm)	60	100	200	300	400	500	600	700	800	900	1000	1100	1200	1300	1400
Average power consumption	6W	10W	20W	30W	40W	50W	60W	70W	80W	90W	100W	110W	120W	130W	140W
Peak power consumption (max 245 ms)	18W	30W	60W	90W	120W	150W	120W	210W	240W	270W	300W	330W	360W	390W	420W
Optical Length XXXX (mm)	1500	1600	1700	1800	1900	2000	2100	2200	2300	2400	2500	2600	2700	2800	2900
Average power consumption	150W	160W	170W	180W	190W	200W	210W	220W	230W	240W	250W	260W	270W	280W	290W
Peak power consumption (max 245 ms)	450W	480W	510W	540W	570W	600W	630W	660W	690W	720W	750W	780W	810W	840W	870W

M12 - 5 pins

M12P - 4 pins

2x M12P - 4 pins

Note: These values are maximum values. The consumption may vary according to the wavelength and the software.

MULTIMODE DRIVER GUIDE (PNP LOGICAL EXAMPLE)

To access the different operating modes, the EFFI-Flex2 must be wired according to the guide below. Please refer to the adequate connector line depending on the light size.

AUTOSTROBE

(450% Overdrive - 100% Continuous)

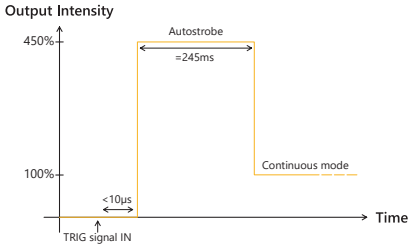

ADJUSTABLE STROBE

(With Intensity control 10%-100%)

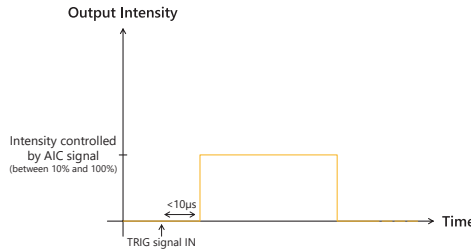

DIMMABLE CONTINUOUS

(With Intensity control 10%-100%)

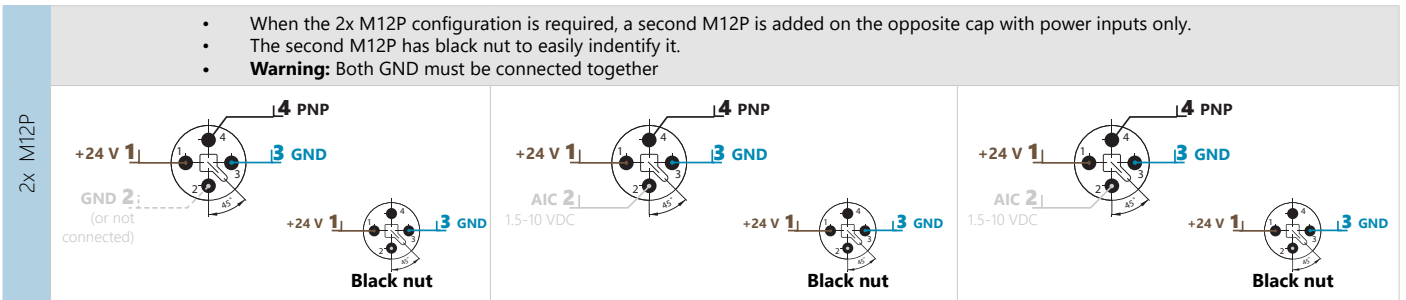
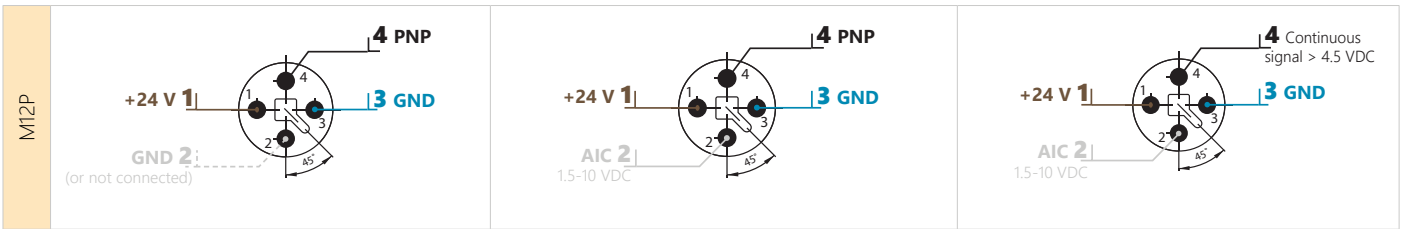
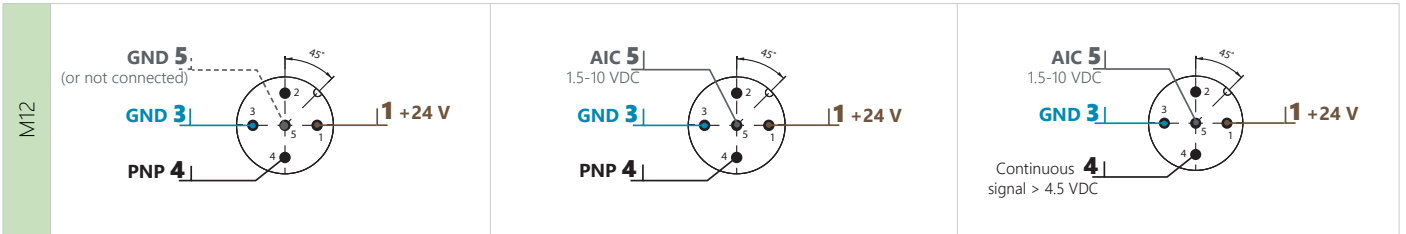
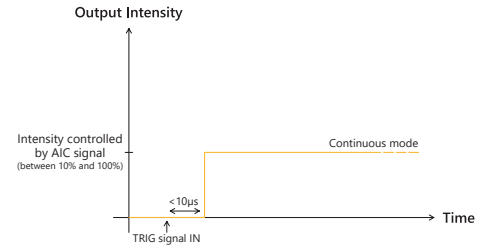

ANALOG INTENSITY CONTROL (AIC)

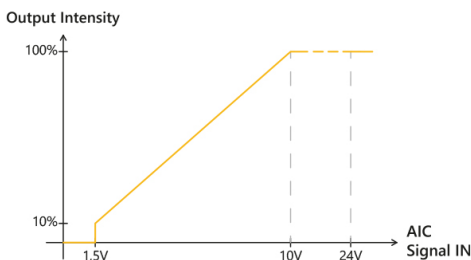

- The output intensity can be adjusted from 10% to 100% by applying a signal from [1.5V-10V DC].
- If $V_{AIC} = [0V-1V DC]$ or if not connected, the EFFI-Flex2 is in AutoStrobe mode by default.

OPTICAL FLEXIBILITY

Be careful to always open the product from the side without the connector.

HOW TO CHANGE THE OPTICAL CONFIGURATION?

The EFFI-Flex2 offers flexible lens positioning to control the beam angle and different type of diffusers to adapt the uniformity. The user can easily change the diffuser and the lens position.



Unscrew the M4 screws and remove the cap (without connector)



Slide out the window and all lenses



Place the lenses & window in desired configuration

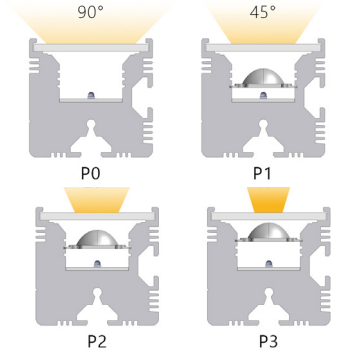

HOW TO INSTALL A POLARIZER ACCESSORY?



Open the EFFI-Flex2 and insert the TR window

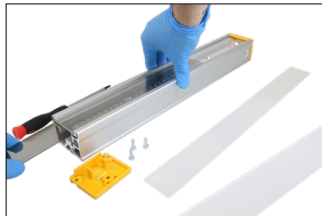

Insert the polarizer under the TR window



Close the product

Important note: The polarization is optimal with a TR window, the use of SD or OP window can depolarize the light.

HOW TO INSTALL A LINESCAN FILM IN YOUR EFFI-FLEX ?



Unscrew the M4 screws.



Place the lens in position P3. Insert the linescan under the TR window.



Close the product.

Important note: If used with a polarizer, be sure to put the polarizer on top of the linescan.

HOW TO INSTALL A CYLINDRICAL LENS IN YOUR EFFI-FLEX ?



Unscrew the M4 screws.



Remove the window and place the lens in **position P1**.



Insert the cylindrical lens window and the linescan below it.



Close the product.

MECHANICAL CONSIDERATION

GENERAL

IP rating	IP5X (dust protected)
Dimensions	60mm x 47mm x Length = Optical length + 35mm
Fixing	One T-slot on the back for M6 T-nuts 8mm slot (2x M6 T-nuts included)

PRODUCT INSTALLATION

EFFI-Flex2 is easily fixed to a frame with its T-NUT M6 nuts, see picture below:

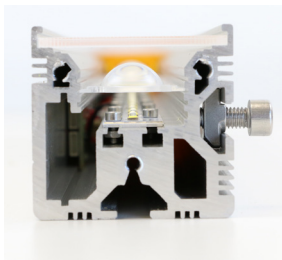

Lateral T-NUT



T-NUT at the rear of the product

DRAWING

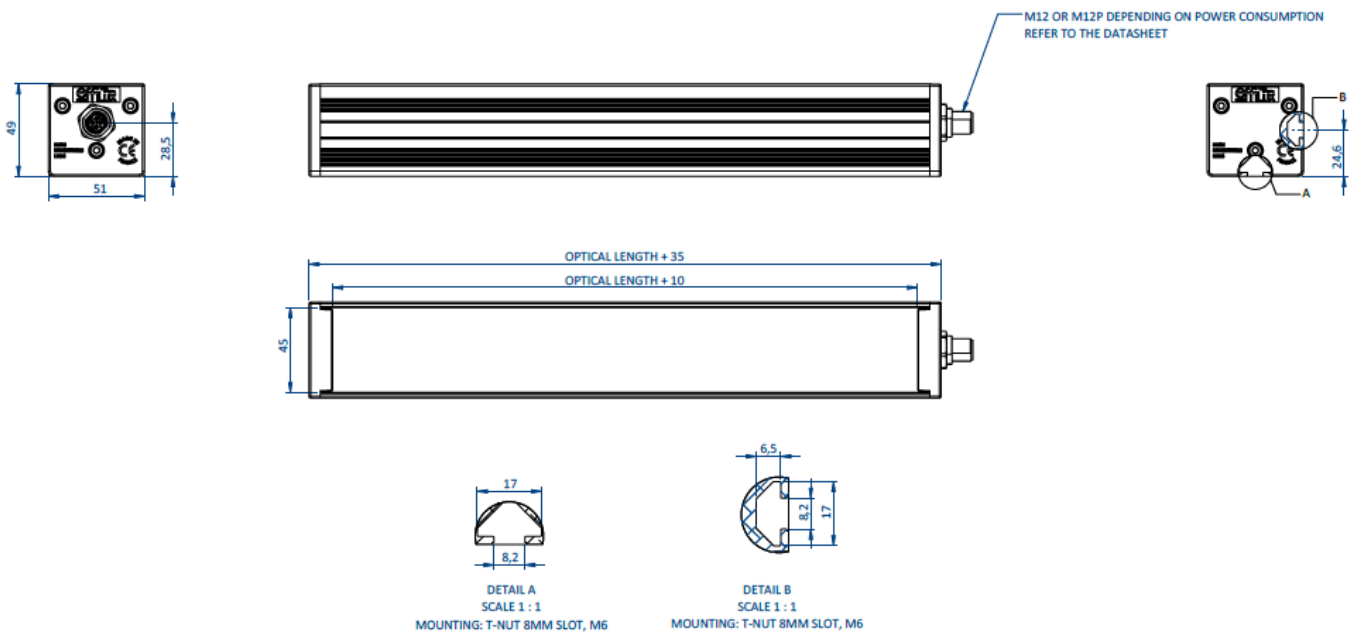

REGULATIONS COMPLIANCY

Regulations & Marking	CE - UKCA
Environmental Standards	RoHS Directives (2011/65/EU, 2015/863/EU and China RoHS) - REACH Regulation - WEEE Regulation
Country of Origin	France - Manufactured by Effilux

ENVIRONMENTAL REGULATIONS

EU RoHS DIRECTIVE

The EU RoHS Directive is short for the «Restriction Of use of certain Hazardous Substances in electrical and electronic equipment». The EU RoHS Directive (2011/65/EU) restricts the use of specific hazardous substances for the new electronic equipment marketed in the EU. The Directive (EU) 2015/863 amending 2011/65/EU was published in 2015 to restrict the use of specific hazardous substances, including six conventional substances, lead (<0.1%), mercury (<0.1%), cadmium (<0.01%), hexavalent chromium (<0.1%), polybrominated biphenyl (PBB) (0.1%) and polybrominated diphenyl ether (PBDE) (<0.1%), as well as four substances (phthalate compounds), bis(2-Ethylhexyl) phthalate (DEHP) (<0.1%), benzyl butyl phthalate (BBP) (<0.1%), dibutyl phthalate (DBP) (<0.1%), diisobutyl phthalate (DIBP) (<0.1%). Our products do not contain the above certain hazardous substances in excess of the maximum permitted concentration. However, this does not apply if the product falls under the exemption.

CHINA ROHS

China RoHS Directive is formally known as «Management Methods for Restricting Hazardous Substances Used in Electric and Electronic Products», which was implemented on July 1st, 2016 in China. Same as EU RoHS Directive (2011/65/EU), this regulation restricts the usage of same six substances. This regulation requires electronic information products which are manufactured or imported, and sold in China, to clearly disclose contents of the 6 restricted substances listed below.

Names and Contents of Hazardous Substances							
Usage Deadline for Environmental Protection	Product name	Names and contents of hazardous substances					
		Lead and its compounds (Pb)	Mercury and its compounds (Hg)	Cadmium and its compounds (Cd)	Hexavalent chromium compounds (Cr(VI))	PBB	PBDE
10	LED Light, Control Unit, or Optional product	×	○	×	○	○	○
(This table is made in compliance with SJ/T11364 regulations.) ○: Indicates that this toxic or hazardous substances contained in all the homogeneous materials for this part, according to GB/T26572 is within the limit requirement. ×: Indicates that this toxic or hazardous substance contained in all the homogeneous materials for this part, according to GB/T26572, is over the limit requirement. *Lead and cadmium are exempted in EU RoHS.							
Usage deadline for environmental protection The number used in this logo is based on "Management Methods for Restricting Hazardous Substances Used in Electric and Electronic Products" and related regulations. It shows the product usage duration in years for environmental protection. After finishing a product usage, the product needs to be re-used or discarded appropriately following local law and regulations, complying with safety and usage caution.							

产品中有害物质的名称及含量							
环保使用期限	产品	有害物质的名称及含量					
		铅及其化合物 (Pb)	汞及其化合物 (Hg)	镉及其化合物 (Cd)	六价铬化合物 (Cr(VI))	多溴联苯 (PBB)	多溴二苯醚 (PBDE)
10	LED 照明、电源或任选件	×	○	×	○	○	○
(本表格依据 SJ/T11364 的规定编制。) ○: 表示该有毒有害物质在该部件所有均质材料中的含量均在 GB/T26572 标准规定的限量要求以下。 ×: 表示该有毒有害物质至少在该部件的某一均质材料中的含量超出 GB/T26572 标准规定的限量要求。 (注) 铅和镉中的“×”，因欧洲联盟 RoHS 没有限定，故用“○”表示。							
环保使用期限 此标志的数字是根据电器电子产品有害物质限制使用管理办法以及相关标准等，表示该产品的环保使用期限的年限。遵守产品的安全和使用上的注意，在产品使用后采取适当的方法根据各地法律，规定，回收再利用或进行废弃处理。							

WARRANTY

EFFILUX products come with a warranty of 2 years (one year for radiant quantity), starting from EFFILUX shipping date. Any improper use voids the warranty.

Exceptions: UV products (<420nm): 1-year warranty / Chillers: 1-year warranty / Polarizers are excluded from warranty.

For more information, please refer to the warranty information available on Effilux's website.

CONTACT INFORMATION

Please refer to the specific documentation (datasheet, user manual and drawing) for complementary information. Contents of this document are based on information available as of December-2022 and may be changed without prior notice.



EFFILUX
 1, Rue de Terre Neuve
 Mini Parc du Verger - Bâtiment E
 91940 Les Ulis - FRANCE

Tel: +33 9 72 38 17 80
 Fax: +33 9 72 11 21 69
 Mail: sales@effilux.fr

UK Importer: Gardasoft Vision Ltd.
 Trinity Court, Buckingham Business Park
 Swavesey, Cambridge CB24 4UQ UK

Copyright 2022 Effilux - All rights Reserved

INFORMATIONS GÉNÉRALES

Effilux vous remercie de votre achat. Afin d'assurer le bon usage du produit, nous vous invitons à prendre connaissance de cette notice (*User manual*) avant utilisation et de la conserver pour vos futurs produits. Toute utilisation inappropriée entraîne une invalidation de la garantie. Ce produit est un éclairage à LED pour la vision industrielle, il ne doit pas être utilisé pour d'autres applications. Le produit doit être utilisé selon les instructions ci-dessous.

Les fiches produits et les plans (PDF et/ou CAO) sont disponibles directement sur le site web Effilux: www.afilux.com

Tous les produits sont étiquetés. Sont indiqués: la référence, la consommation, la tension d'alimentation requise et le numéro de série du produit. Assurez-vous que la référence corresponde à votre usage et que vous avez pris connaissance des informations indiquées sur l'étiquette. La date de fabrication est incluse dans le numéro de série du produit: XXXXXYYMM-ZZZ avec YY correspondant à l'année, MM au mois. Si l'étiquette est manquante ou endommagée de sorte à ce que les informations ne puissent pas être lues, contactez Effilux.

PRÉCAUTIONS D'EMPLOI

MAINTENANCE

Le produit doit être éteint durant toute opération de maintenance. Pour enlever des marques sur les lentilles ou la vitre, utilisez un nettoyant liquide sans alcool dédié sur un tissu propre. Quelques gouttes suffisent. Nettoyez délicatement, appliquez toujours le nettoyant sur le tissu plutôt que sur les lentilles directement. Pour le nettoyage des composants optiques, portez des gants et utilisez de l'air comprimé pour évacuer la poussière.

CONDITIONS DE STOCKAGE ET D'UTILISATION

Conditions de fonctionnement	Température: 0 to 50°C - Humidité: 20 à 85RH% (sans condensation) - Altitude: jusqu'à 2000m
Conditions de stockage	Température: -20 to 60°C - Humidité: 20 à 85RH% (sans condensation)
Informations	Overvoltage category I - Protective class III - Pollution degree 3

A part si le produit possède un indice de protection IP particulier, veillez à installer le produit dans les conditions ci-dessous (*Consultez la section indice de protection d'intrusion des solides et intrusion eau, une installation ne respectant pas les conditions énoncées est susceptible d'entraîner une défaillance du produit*) :

Espace aéré avec un minimum de poussière	Espace sans liquide, produits chimiques ou vapeur.
Espace sans gaz corrosifs ou combustibles	Espace non soumis à de rapides variations de température
Espace sans présence d'arrivée d'eau, chaudière, humidificateurs, climatisation, chauffage ou cuisinière.	

SÉCURITÉ DE L'UTILISATEUR

Une utilisation non appropriée peut entraîner un départ de feu, une décharge électrique ou des phénomènes représentant un danger. Assurez-vous de suivre les conditions d'utilisation dans le tableau ci-dessous. Si vous constatez l'apparition de phénomènes suspects comme un dégagement de fumée, un échauffement anormal, des bruits anormaux,...) coupez immédiatement l'alimentation du produit.

Ne pas désassembler ou modifier le produit	Ne pas regarder directement la lumière émise sans protection oculaire
Ne pas tenter de réparer le produit par ses propres moyens	Assurez-vous de porter des lunettes de protection en cas de lumière UV <420nm
Ne pas toucher le produit avec des mains humides	Ne pas utiliser de câbles non industriels
Connectez et gardez les fils nus dans une zone sèche (indépendamment de l'indice de protection du produit)	Contrôlez que le produit ne présente aucune trace de moisissure ou de liquide à l'intérieur lorsque vous l'allumez.
Assurez-vous que l'alimentation et les câbles/connecteurs sont adaptés aux spécifications du produit	Le produit doit être alimenté en 24 VDC selon les règles de sécurité électriques locales.
Ne pas inverser les pôles électriques - vérifiez les connexions et les conventions	Les éléments d'emballages doivent être retirés avant utilisation.

PART NUMBERING

VERSION STANDARD

EFFI-FLEX2	- ...	- XXXX	- ZZZ	- WW	- PP
	Densité de LED	Longueur Optique [mm]	Longueur d'onde [nm]	Diffuseur	Position de lentille
	Ø (Standard si non spécifié)	60	● 405 (UV)	TR (Transparent)	P0 (90°)
	X2 (Densité LED x2)	100	● 465 (Bleu)	SD (Semi-diffus)	P1 (45°)
	L2 (Densité LED ÷2)	200	● 525 (Vert)	OP (Opaline)	P2 (25°)
	L4 (Densité LED ÷4)	300	● 625 (Rouge)		P3 (10°)
		... Pas de 100mm	● 850 (Infrarouge)		
		2900	○ 000 (Blanc)		

OPTIONS DISPONIBLES: RÉFÉRENCES

Pour plus d'informations sur les options voir les sections dédiées de la datasheet du EFFI-Flex2.

OPTIQUE	
Kit avec tous les diffuseurs	EFFI-FLEX2-XXXX-ZZZ-KIT Un EFFI-Flex2 avec l'option KIT est livré avec les lentilles en position P2 et un diffuseur SD (Semi-diffus). Une fenêtre transparente et un diffuseur OP (Opaline) sont ajoutés au package et offre ainsi davanatge de flexibilité
Accessoire: Polariseur	EFFI-FLEX2-XXXX-ZZZ-WW-PP-POL
Longueur d'onde UV 365nm	EFFI-FLEX2-XXXX-365-TR-P0
Film Linescan	EFFI-FLEX2-XXXX-ZZZ-TR-P3-LS
Lentille cylindrique	EFFI-FLEX2-XXXX-ZZZ-TR-P1-LS-CYL
ELECTRONIQUE	
Mode continu: configurations spécifiques	EFFI-FLEX2-XXXX-ZZZ-WW-PP-ELS-UUU-VVV
Software customisé	EFFI-FLEX2-XXXX-ZZZ-WW-PP-SWxxxxxx Une référence spécifique de type xxxxxx pour chaque software customisé.
CONNECTEURS	
Position et orientation du connecteur, position des câbles	EFFI-FLEX2-XXXX-ZZZ-WW-PP-SCXXX/OSC/BSC/SCG

*YY = Type of outlet UK, CH, EU, US, ...

ACCESSOIRES

Pour plus d'informations sur les options voir les sections dédiées de la datasheet du EFFI-Flex2.

DIFFUSEURS	Transparent: EFFO-FLEX2-TR-XXXX Semi-diffus: EFFO-FLEX2-SD-XXXX Opaline: EFFO-FLEX2-OP-XXXX	
POLARISEUR	EFFO-FLEX2-POL-XXXX	
ALIMENTATIONS	Alimentation: EFFI-PWR-WWW-24V-102-YY* Alimentation compacte: EFFI-SPWR-090W-24V-102-YY**	
CABLES avec FILS NUS	Avec Connecteur M12 - 5 pins	Avec Connecteur M12P - 4 pins
	2 m: EFFC-CAB-M12-F-5-D-L2 5 m: EFFC-CAB-M12-F-5-D-L5 10 m: EFFC-CAB-M12-F-5-D-L10	2 m: EFFC-CAB-M12P-F-4-D-L2 5 m: EFFC-CAB-M12P-F-4-D-L5 10 m: EFFC-CAB-M12P-F-4-D-L10
CABLES D'EXTENSION	Avec Connecteur M12 - 5 pins	Avec Connecteur M12P - 4 pins
	2 m: EFFC-CAB-M12-FM-5-DD-L2 5 m: EFFC-CAB-M12-FM-5-DD-L5 10 m: EFFC-CAB-M12-FM-5-DD-L10	2 m: EFFC-CAB-M12P-FM-4-DD-L2 5 m: EFFC-CAB-M12P-FM-4-DD-L5 10 m: EFFC-CAB-M12P-FM-4-DD-L10
FIXATIONS	Kit T-Nut: EFFV-BOLT-0011 Kit Rotule: EFFM-1-0002	
FILTRES CAMERAS	EFFO-FLR-...	

INSTALLATION ELECTRIQUE - CONFIGURATION DE CONNEXION

ALIMENTATION

Tension d'alimentation		24V DC (+/-10%)			
Connecteur(s) <i>(Voir plan de câblage page suivante)</i>	Longueur Optique	60mm - 400mm	500mm - 1500mm	1600mm - 2900mm	
	Type	M12 (A-coded) - 5 pins	M12 Power (T-coded) - 4 pins	2x M12 Power (T-coded) - 4 pins	
Consommation*	Pic	Max. 30W par 100 mm			
	Moyenne	Max. 10W par 100mm			
Version de driver		Multimode (3 modes: AutoStrobe avec intensité «overdrive» / Strobe ajustable / Continu ajustable)			
Contrôle d'intensité analogique (AIC)		La puissance optique en sortie de produit est ajustable de 10% à 1000% en appliquant un signal compris en 1.5V et 10V DC. La plage totale de tension est [1.5V-24VDC] / Ne pas dépasser 24V DC / Consommation maximale du signal: 4mA			
AutoStrobe		450% Overdrive pendant 245 ms max puis continu à 100%			
		Rapport cyclique maximal 30%			
		Signal de déclenchement (PNP): Produit allumé en overdrive si V_{PNP} passe de 0V à [4.5V*-24V] Ne pas dépasser 24V DC / Consommation maximale su signal: 4mA. <i>(Option NPN pour les tailles \geq 500mm, sur la PIN4: Produit allumé en overdrive si V_{PNP} passe de 24V à [0V-1V] Ne pas dépasser 24V DC / Consommation maximale su signal: 4mA)</i>			
Temps de réponse		Max. 10 μ s (<i>Temps de montée inclus</i>)			

***Note 1:** Les valeurs annoncées de consommation sont des valeurs maximales, la consommation exacte du produit est systématiquement indiquée sur l'étiquette produit.

****Note 2:** Le seuil de tension de déclenchement PNP de 4.5V peut être amené à varier en fonction de la longueur de câble et vary with cable lengths and power consumption. Please refer to the following table.

Max. PNP voltage threshold (V)														
Cable length (0.34mm ² section)	Max. power consumption during overdrive in AutoStrobe mode													
	20W	30W	40W	60W	80W	100W	120W	145W	170W	220W	270W	320W	370W	420W
2m	4.3	4.4	4.4	4.5	4.6	4.6	4.4	4.5	4.5	4.6	4.6	4.7	4.8	4.9
5m	4.5	4.5	4.6	4.8	5.0	5.2	4.7	4.8	4.9	5.0	5.2	5.4	5.6	5.8
10m	4.6	4.8	5.0	5.4	5.8	6.3	5.1	5.3	5.5	5.9	6.3	6.8	7.4	8.1
15m	4.8	5.1	5.4	6.0	6.8	7.7	5.6	5.9	6.2	6.9	7.9	9.2		
20m	5.0	5.4	5.8	6.8	8.1		6.1	6.5	7.1	8.4				

M12 - 5 pins

M12P - 4 pins

COMMENT CONNECTER L'EFFI-FLEX2 ?

Selon la longueur du produit, l'EFFI-Flex2 comporte un connecteur M12 5 broches ou connecteur M12 Power 4 broches ou deux M12 Power 4 broches. (Voir le tableau des consommations et des définitions de connecteur page suivante).

M12 (A-coded)- 5 pins

Connecteur mâle

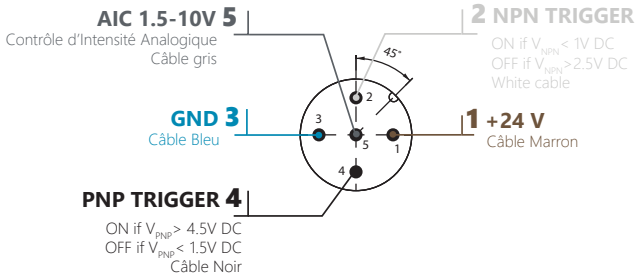

M12 Power (T-coded) - 4 pins

Connecteur mâle

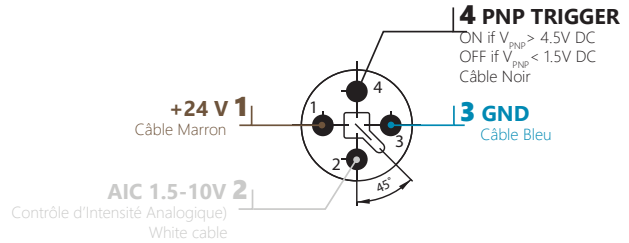

Notes:

- L'EFFI-Flex2 requiert une tension d'alimentation de 24V DC.
- Le broche de déclenchement PNP (ou NPN) a besoin d'être connectée soit à un signal de déclenchement pour les modes AutoStrobe et Strobe ajustable soit à un signal continu pour le mode Continu ajustable. (Voir le guide du fonctionnement Multimode page suivante).
- Pour les éclairages munis d'un connecteur M12P, le signal de déclenchement NPN est en option, dans ce cas, le signal d'entrée PNP est remplacé par le signal d'entrée NPN. (Voir le guide du fonctionnement Multimode en Annexe)

CONSOMMATION & DÉFINITION DE CONNECTEURS

CONSOMMATION MAXIMALE (+/- 5%) (LED Blanche - Software Standard- Rapport cyclique 30%)															
Longueur optique XXXX (mm)	60	100	200	300	400	500	600	700	800	900	1000	1100	1200	1300	1400
Consommation moyenne	6W	10W	20W	30W	40W	50W	60W	70W	80W	90W	100W	110W	120W	130W	140W
Consommation pic (245ms)	18W	30W	60W	90W	120W	150W	120W	210W	240W	270W	300W	330W	360W	390W	420W
Longueur optique XXXX (mm)	1500	1600	1700	1800	1900	2000	2100	2200	2300	2400	2500	2600	2700	2800	2900
Consommation moyenne	150W	160W	170W	180W	190W	200W	210W	220W	230W	240W	250W	260W	270W	280W	290W
Consommation pic (245ms)	450W	480W	510W	540W	570W	600W	630W	660W	690W	720W	750W	780W	810W	840W	870W

GUIDE DE FONCTIONNEMENT MULTIMODE (EXEMPLE LOGIQUE PNP)

Afin de faire fonctionner l'EFFI-Flex2 dans le mode désiré, il doit être connecté selon le guide ci-dessous. Veuillez vous référer à la ligne correspondant au connecteur de votre éclairage.

AUTOSTROBE

(450% Overdrive - 100% Continu)

ADJUSTABLE STROBE

(Contrôle d'intensité 10%-100%)

DIMMABLE CONTINUOUS

(Contrôle d'intensité 10%-100%)

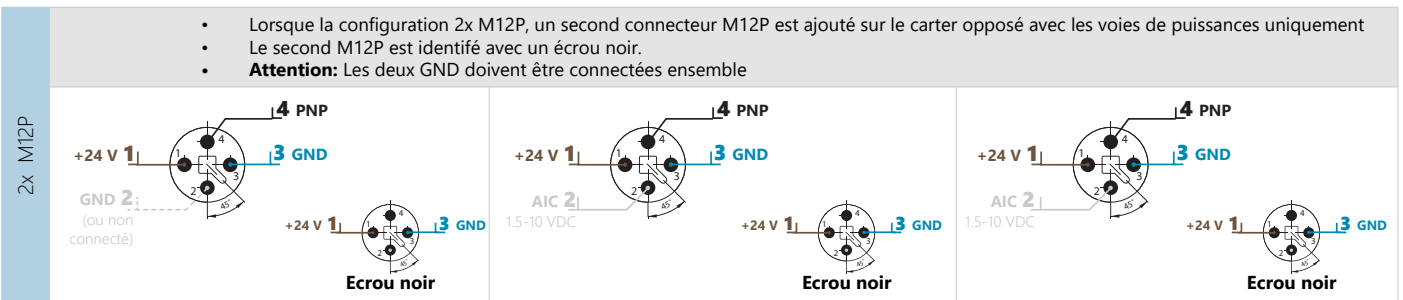
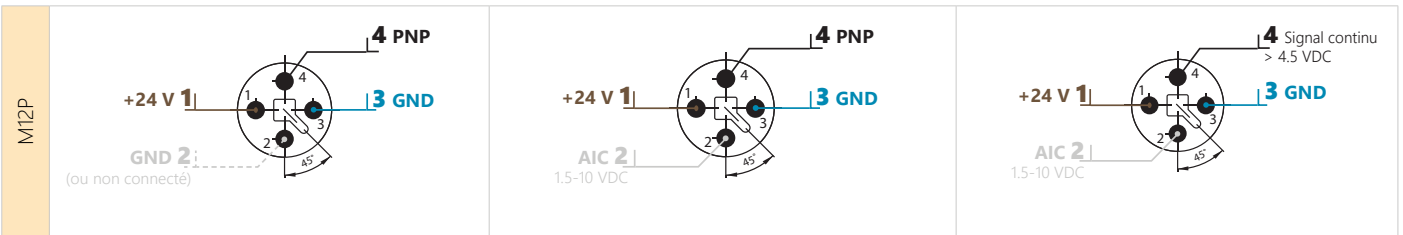
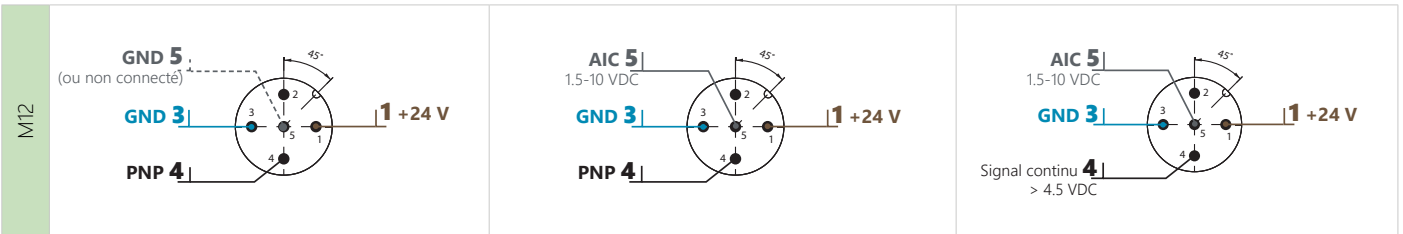
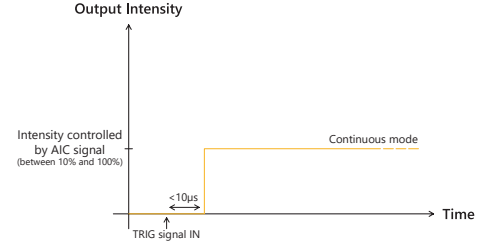
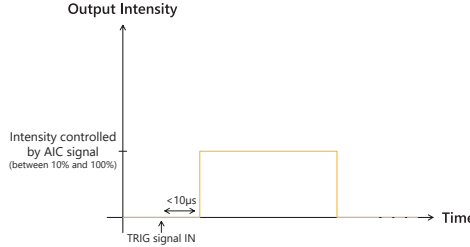
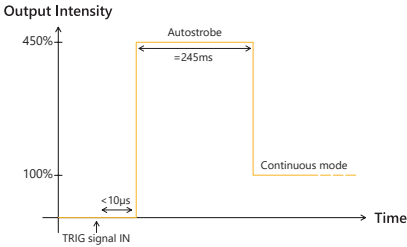

CONTRÔLE D'INTENSITÉ ANALOGIQUE (AIC)

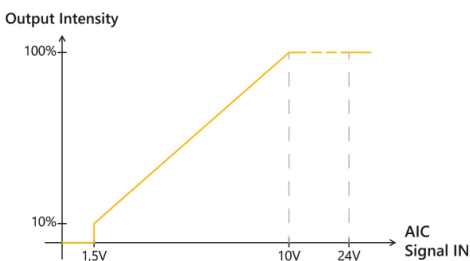

- L'intensité optique de sortie peut être ajustée de 10% à 100% en appliquant un signal entre 1.5V et 10V DC.
- Si $V_{AIC} = [0V-1V DC]$ ou bien que l'AIC n'est pas connectée, l'EFFI-Flex2 est en mode AutoStrobe par défaut.

FLEXIBILITE OPTIQUE

Attention: Toujours ouvrir le produit par la face sans connecteur.

COMMENT CHANGER LA CONFIGURATION OPTIQUE ?



Dévissez les 3 vis M4 CHC et retirez le carter plastique



Retirez les lentilles et le diffuseur en les faisant coulisser



Positionnez les lentilles à la hauteur souhaitée et glissez le diffuseur approprié. Refermez le produit en revissant le carter plastique

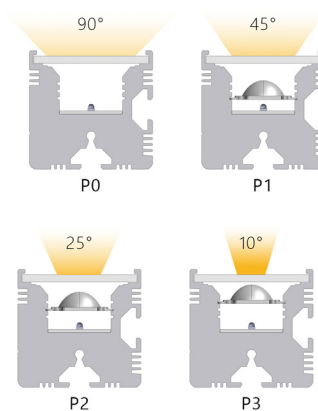

COMMENT INSTALLER LE POLARISEUR ?



Dévissez les 3 vis M4 CHC et retirez le carter plastique

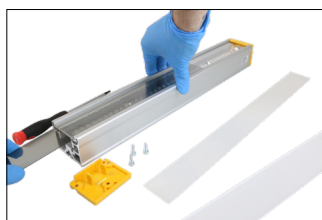

Insérez le polariseur sous la vitre



Refermez le produit

Note importante: La polarisation est optimale avec la vitre transparente TR. L'utilisation des diffuseurs SD et OP peut dépolariiser la lumière.

COMMENT INSTALLER LE FILM LINESCAN ?



Dévissez les 3 vis M4 CHC et retirez le carter plastique et la vitre.



Placez les lentilles en **position P3** et insérez le film sous la vitre TR



Refermez le produit

Note important: Si le film linescan est utilisé avec un polariseur, assurez-vous de le placer sous le polariseur.

COMMENT INSTALLER LA LENTILLE CYLINDRIQUE?



Dévissez les 3 vis M4 CHC et retirez le carter plastique.



Retirez la vitre et placez les lentilles en **position P1**



Insérez la lentilles cylindrique et placez le film linescan sous celle-ci



Refermez le produit

CONSIDERATIONS MECANIQUES

Indice de protection IP	IP5X (protégé contre la poussière)
Dimensions	60mm x 47mm x Longueur = Longueur optique + 35mm
Fixation	Une rainure type T-slot au dos du produit pour T-nuts M6 8mm (2x M6 T-nuts non inclus)

INSTALLATION DU PRODUIT

L'EFFI-Flex2 se fixe facilement à un chassis grâce à ses écrous T-NUT M6, voir photo ci-dessous:

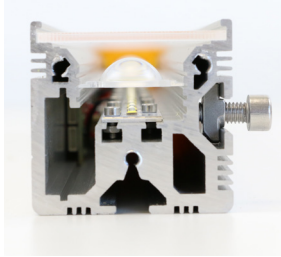

T-NUT Latéral

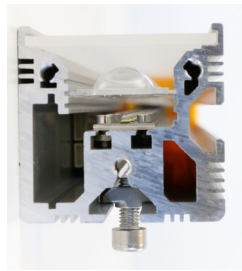

T-NUT à l'arrière du produit

DRAWING

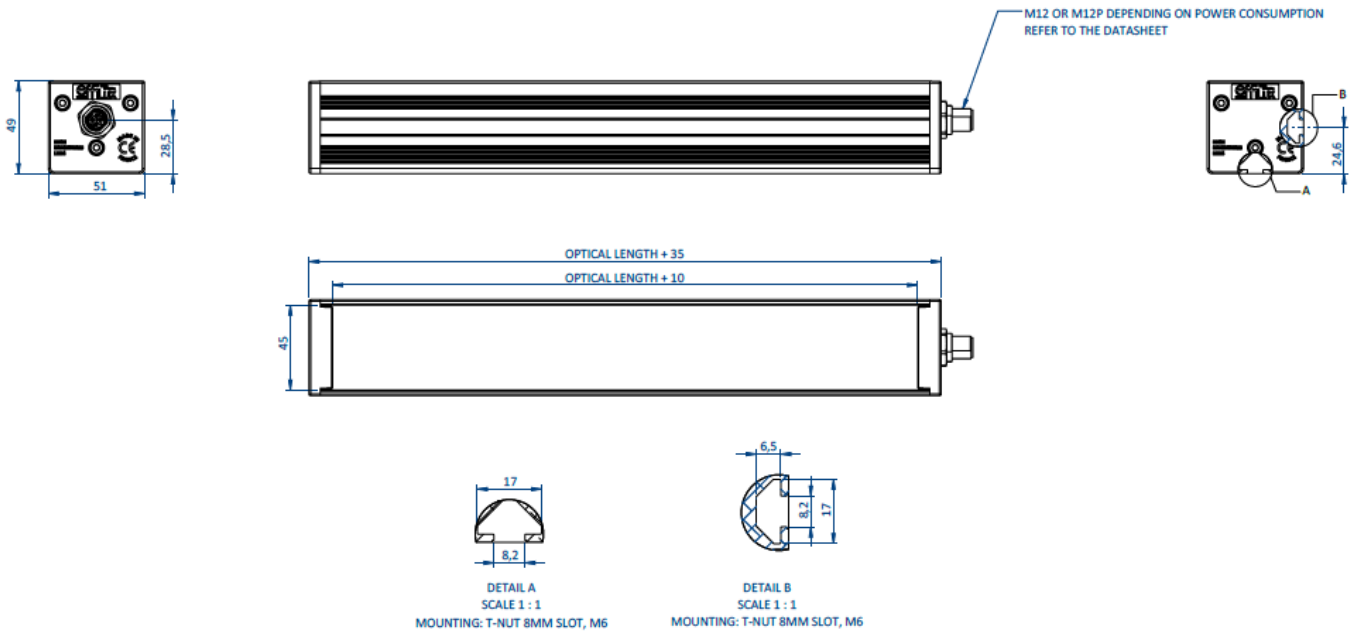

Réglementation et marquage	CE - UKCA
Directives environnementales	RoHS Directives (2011/65/EU, 2015/863/EU and China RoHS) - REACH Regulation - WEEE Regulation
Pays d'origine	Fabriqué en France par Effilux Fabriqué en France par Effilux

DIRECTIVES ENVIRONNEMENTALES

EU RoHS DIRECTIVE

La directive européenne EU RoHS est l'acronyme de «Restriction Of use of certain Hazardous Substances in electrical and electronic equipment». La directive EU RoHS (2011/65/EU) restreint l'emploi de certaines substances dangereuses pour les nouveaux équipements électroniques vendus sur le marché de l'UE. La directive EU 2015/863 amende 2011/65/EU a été publiée en 2015 afin de restreindre l'utilisation de substances dangereuses spécifiques, notamment six substances conventionnelles, le plomb (<0,1 %), le mercure (<0,1 %), le cadmium (<0,01 %), le chrome hexavalent (<0,1 %), le polybromobiphényle (PBB) (0. 1%) et éther diphenylique polybromé (PBDE) (<0,1%), ainsi que quatre substances (composés de phtalate), phtalate de bis(2-Ethylhexyle) (DEHP) (<0,1%), phtalate de benzyle et de butyle (BBP) (<0,1%), phtalate de dibutyle (DBP) (<0,1%), phtalate de diisobutyle (DIBP) (<0,1%). Nos produits ne contiennent pas les substances dangereuses mentionnées ci-dessus dans une proportion supérieure à la limite maximale autorisée.

Ceci ne s'applique pas si le produit bénéficie d'une exemption.

CHINA ROHS

La directive China RoHS est aussi connue sous le nom de «Management Methods for Restricting Hazardous Substances Used in Electric and Electronic Products», mise en place le 1er Juillet 2016 en Chine. Tout comme la directive EU RoHS (2011/65/EU), elle a pour but de restreindre l'utilisation de ces six mêmes substances. Cette directive exige une transparence quant à la présence de 6 substances réglementées énumérées ci-dessous dans les produits électroniques fabriqués ou importés, et vendus en Chine.

Names and Contents of Hazardous Substances

Usage Deadline for Environmental Protection	Product name	Names and contents of hazardous substances					
		Lead and its compounds (Pb)	Mercury and its compounds (Hg)	Cadmium and its compounds (Cd)	Hexavalent chromium compounds (Cr(VI))	PBB	PBDE
	LED Light, Control Unit, or Optional product	×	○	×	○	○	○
(This table is made in compliance with SJ/T11364 regulations.) ○: Indicates that this toxic or hazardous substances contained in all the homogeneous materials for this part, according to GB/T26572 is within the limit requirement. ×: Indicates that this toxic or hazardous substance contained in all the homogeneous materials for this part, according to GB/T26572, is over the limit requirement. *Lead and cadmium are exempted in EU RoHS.							
Usage deadline for environmental protection The number used in this logo is based on "Management Methods for Restricting Hazardous Substances Used in Electric and Electronic Products" and related regulations. It shows the product usage duration in years for environmental protection. After finishing a product usage, the product needs to be re-used or discarded appropriately following local law and regulations, complying with safety and usage caution.							

产品中有害物质的名称及含量

环保使用期限	产品	有害物质的名称及含量					
		铅及其化合物 (Pb)	汞及其化合物 (Hg)	镉及其化合物 (Cd)	六价铬化合物 (Cr(VI))	多溴联苯 (PBB)	多溴二苯醚 (PBDE)
	LED 照明、电源或任选件	×	○	×	○	○	○
(本表格依据 SJ/T11364 的规定编制。) ○: 表示该有毒有害物质在该部件所有均质材料中的含量均在 GB/T26572 标准规定的限量要求以下。 ×: 表示该有毒有害物质至少在该部件的某一均质材料中的含量超出 GB/T26572 标准规定的限量要求。 (注) 铅和镉中的“×”，因欧洲联盟 RoHS 没有限定，故用“○”表示。							
环保使用期限 此标志的数字是根据电器电子产品有害物质限制使用管理办法以及相关标准等，表示该产品的环保使用期限的年数。遵守产品的安全和使用上的注意，在产品使用后采取适当的方法根据各地法律、规定，回收再利用或进行废弃处理。							

GARANTIE

Les produits EFFILUX sont garantis 2 ans (1 an pour le niveau d'intensité lumineuse). La garantie démarre à la date d'expédition d'EFFILUX. Tout usage non approprié entraîne une invalidité de la garantie.

Exceptions: produits UV (<420nm): garantis 1 an / Systèmes de refroidissement: garantis 1 an / Les polariseurs ne sont pas concernés par la garantie.

Pour plus d'informations, veuillez consulter les informations relatives à la garantie disponibles sur le site web d'Efflux.

CONTACT

Si vous souhaitez des informations complémentaires, veuillez consulter les documents techniques associés (datasheet, user manual et drawing). Les informations contenues dans ce document sont datées de Décembre 2022 et peuvent être modifiées sans notification préalable.



EFFILUX
1, Rue de Terre Neuve
Mini Parc du Verger - Bâtiment E
91940 Les Ulis - FRANCE

Tel: +33 9 72 38 17 80
Fax: +33 9 72 11 21 69
Mail: sales@efflux.fr

UK Importer: Gardasoft Vision Ltd.
Trinity Court, Buckingham Business Park
Swavesey, Cambridge CB24 4UQ UK

Copyright 2022 Efflux - All rights Reserved