



SVS-VISTEK

# exo250ZGE

Polarized

The Polarized cameras measure the degree of polarization and the planes of polarization from a single image. The high resolution with global shutter, the high optical dynamic and high frame rate allow detailed structural analysis of even moving objects.

The cameras are based on our fanless EXO industrial camera with milled aluminum body.

## Technical Highlights

- > LUT, ROI, Burst Mode
- > Electrical and optical inputs
- > Up to 60°C operating temperature
- > Integrated 4-channel strobe controller
- > Industrial TTL-24V I/O interface with SafeTrigger, logic functions, programmable sequencers and timers, RS232 interface



**Polarsens**

SVS-Vistek GmbH - Ferdinand-Porsche-Str. 3 - 82205 Gilching - Germany - Telephone +49 8105 3987-60

Information accurate as to: 16.11.2022, errors and omissions excepted.

© 2022 – SVS-Vistek GmbH, all rights reserved.

# SWIR / UV / Polarized Series exo250ZGE

Resolution [MP]	5 MP
Resolution (h x v)	2448 x 2048 px
Frame rate (max.)	24.5 fps
Frame rate burst mode (max.)	42.7 fps
Chroma	mono polarized
Interface	GigE Vision

## Sensor

Sensor	IMX250MZR (polarized)
Manufacturer	Sony
Sensor type	Area CMOS
Shutter type	global shutter
Sensor size (h x v)	8.45 x 7.07 mm
Optical diagonal	11.01 mm
Sensor format	2/3 "
Pixel size (h x v)	3.45 x 3.45 $\mu\text{m}$

## Camera

Exposure modes	MANUAL;AUTO;EXTERNAL
Trigger modes	INTERNAL;SOFTWARE;EXTERNAL
Exposure time (min)	20 $\mu\text{s}$
Exposure time (max)	1 sec (external $\infty$ )
Pixel format / max	mono8, mono12packed / 12 bit
Gain modes / max	manual, auto / 48 dB
S/N ratio (max)	40 dB (dep. on environment)
Dynamic range (max)	72 dB (dep. on environment)
Internal memory	256 MB SDRAM, 32 MB Flash

## Feature Set

AOI	yes
LUT	yes
Offset	yes
Readout control	yes
Binning	yes
Image flip	yes
Shading correction	yes
Defect pixel correction	yes
Sequencer	yes
POE	yes
PTP	yes

## Housing

Lens mount	C-Mount
Dimensions (w x h x d)	50 x 50 x 43 mm
Weight	138 g
Operating temperature (housing)	-10 to 60 °C
Ambient humidity	10 to 90 % (non-condensing)
Protection class	IP40

## I/O-Interfaces

# Dimensions [mm]

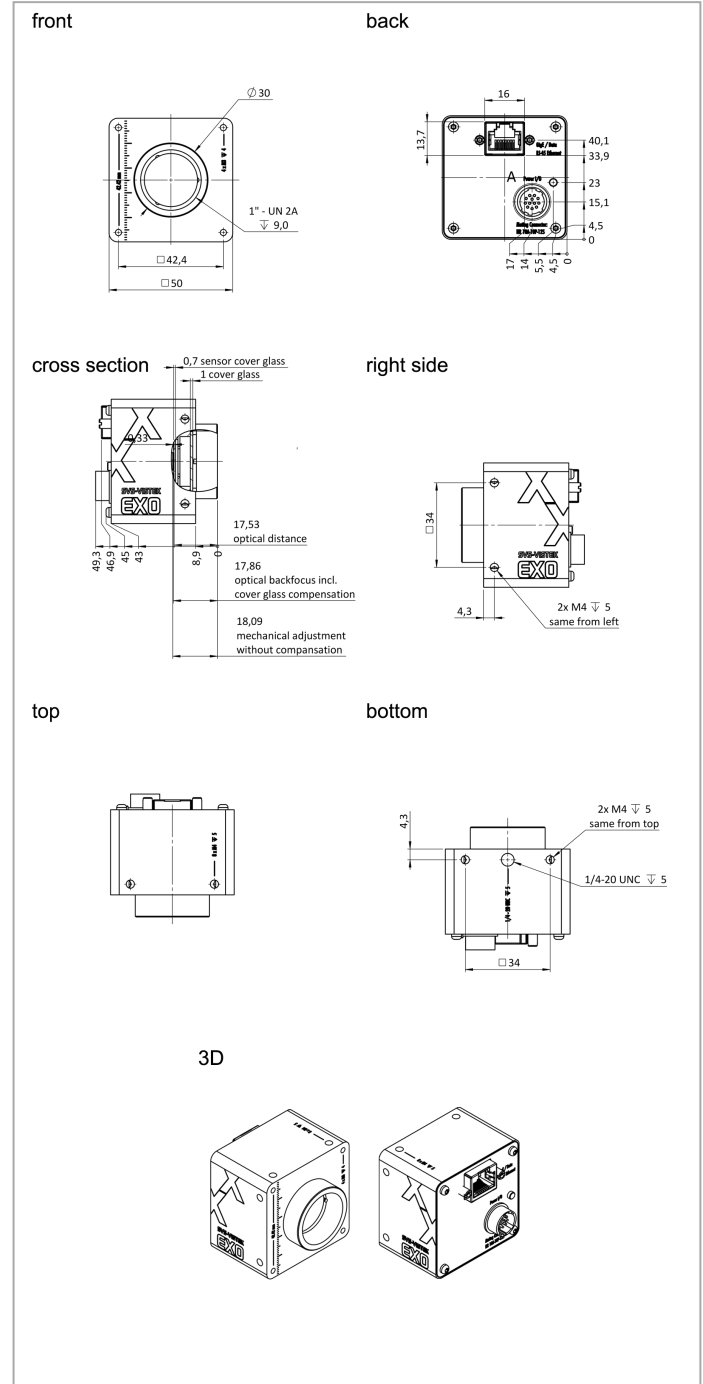

# Pinout Mating Connector

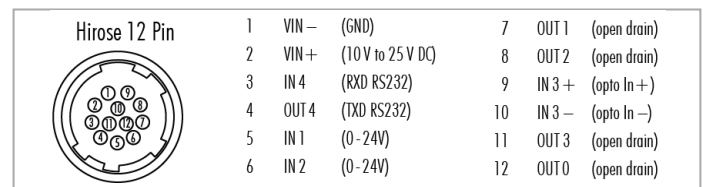

# Spectral Response \*

Input up to 24V	2 x
Input OPTO	1 x
Output open drain	4 x
I/O RS-232	1 x
Power supply	10 to 25 V (DC)
Power consumption	4.5 W (dep. on operating mode)

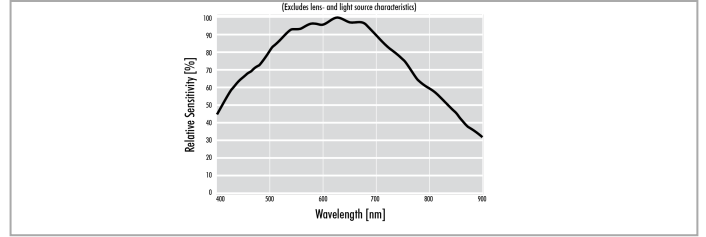

\* Sensor data – excludes camera cover- or IR-cut filter characteristics